

**NOTICE OF REGULAR MEETING
CITY OF SOUTH PADRE ISLAND
CITY COUNCIL MEETING**

NOTICE IS HEREBY GIVEN THAT THE CITY COUNCIL OF THE CITY OF SOUTH PADRE ISLAND, TEXAS, WILL HOLD A REGULAR MEETING ON:

WEDNESDAY, JULY 17, 2019

5:30 P.M. AT THE MUNICIPAL BUILDING,
CITY COUNCIL CHAMBERS, 2ND FLOOR

4601 PADRE BOULEVARD, SOUTH PADRE ISLAND, TEXAS

1. Call to order
2. Pledge of Allegiance and Texas Pledge
3. Installation and administration of oaths to newly elected officials:
 - a. Newly elected Mayor – Patrick McNulty
4. Recognition of out-going Mayor Dennis Stahl.
5. Public Comments and Announcements: *This is an opportunity for citizens to speak to Council relating to agenda or non-agenda items. Speakers are required to address Council at the podium and give their name before addressing their concerns. [Note: State law will not permit the City Council to discuss, debate or consider items that are not on the agenda. Citizen comments may be referred to City Staff or may be placed on the agenda of a future City Council meeting]*
6. Presentations and Proclamations:
 - a. Presentation: Recognition of the TAMIO (Texas Association of Municipal Information Officers) Award of Excellence recipient
7. Approve Consent Agenda:
 - a. Approve minutes of June 19, 2019 workshop and regular meeting, July 10, 2019 special meeting. (Manning)
 - b. Approve invoices for payment. (Gimenez)
 - c. Approve a budget amendment for \$7,000 for professional services to conduct Phase 2 (final phase) of the internal Municipal Court audit. (Vasquez/Delgado)
 - d. Approve an excused absence for Council Member Kerry Schwartz from the July 10, 2019 special meeting. (Schwartz)
 - e. Approve second and final reading of Ordinance No. 19-10 amending Chapter 4 by repealing and replacing Section 4-17 and 4-18 to provide regulations regarding substandard structures, create a review board to provide for public hearings and remediation regarding the same and dealing with related matters. (Hanley/Travis)
8. Discussion and action to approve the South Padre Island Economic Development Corporation's annual budget for fiscal year 2019/20. (Furcron)

9. Discussion and action to prohibit sound devices that emit noise, such as blue tooth, stereo systems on commercial/rental golf carts within the city limits. (Ricco/Schwartz)
10. Discussion and action to regulate and limit the number of motorized golf cart rental license plates issued for commercial rental. (Ricco/Schwartz)
11. Discussion and action to approve a budget amendment to allocate funds in the amount of \$500,000 to reflect the grant received from Texas Parks and Wildlife to complete Phase II of John L. Tompkins Park. (Huffman)
12. Discussion and action to proceed with Request for Qualifications for design services for the skatepark portion of the John L. Tompkins Park Phase II. (Hanley/Schwartz/Huffman)
13. Discussion and action to proceed or make changes to the proposed Palm Street Boat Ramp and Sunset Beach Access projects (tabled from the June 19, 2019 Council meeting). (Boburka)
14. Discussion and action to approve a three-year contract term with Pro WaterCross and authorize the City Manager to sign the contract. (Caum)
15. Discussion and action to approve a budget amendment in the amount of \$49,999.55 for the replacement of three virtualization servers and backup hardware and associated software. (Shellard)
16. Adjourn.

WE RESERVE THE RIGHT TO GO INTO EXECUTIVE SESSION REGARDING ANY OF THE ITEMS POSTED ON THIS AGENDA, PURSUANT TO SECTIONS 551.071, CONSULTATION WITH ATTORNEY; 551.072, DELIBERATIONS ABOUT REAL PROPERTY; 551.073, DELIBERATIONS ABOUT GIFTS & DONATIONS; 551.074, PERSONNEL MATTERS; 551.076, DELIBERATIONS ABOUT SECURITY DEVICES; AND/OR 551.087, DISCUSS (1) COMMERCIAL OR FINANCIAL INFORMATION RECEIVED FROM A BUSINESS PROSPECT WITH WHICH THE CITY IS CONDUCTING NEGOTIATIONS, OR (2) FINANCIAL OR OTHER INCENTIVES TO THE BUSINESS PROJECT.

DATED THIS THE 12TH DAY OF JULY 2019

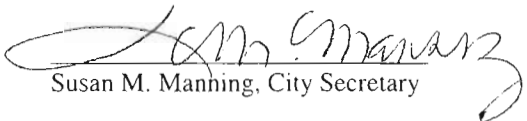
Susan M. Manning, City Secretary

I, THE UNDERSIGNED AUTHORITY, DO HEREBY CERTIFY THAT THE ABOVE NOTICE OF MEETING OF THE GOVERNING BODY OF THE CITY OF SOUTH PADRE ISLAND, TEXAS IS A TRUE AND CORRECT COPY OF SAID NOTICE AND THAT I POSTED A TRUE AND CORRECT COPY OF SAID NOTICE ON THE BULLETIN BOARD AT CITY HALL/MUNICIPAL BUILDING ON **JULY 12, 2019**, AT/OR BEFORE 5:00 P.M. AND REMAINED SO POSTED CONTINUOUSLY FOR AT LEAST 72 HOURS PRECEDING THE SCHEDULED TIME OF SAID MEETING.

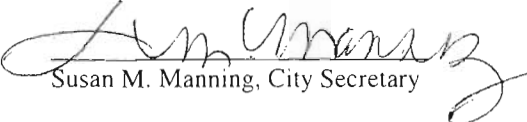

Susan M. Manning, City Secretary

THIS FACILITY IS WHEELCHAIR ACCESSIBLE, AND ACCESSIBLE PARKING SPACES ARE AVAILABLE. REQUESTS FOR ACCOMMODATIONS OR INTERPRETIVE SERVICES MUST BE MADE 48 HOURS PRIOR TO THIS MEETING. PLEASE CONTACT BUILDING OFFICIAL, DAVID TRAVIS: ADA DESIGNATED RESPONSIBLE PARTY AT (956) 761-8103.

**CITY COUNCIL MEETING
CITY OF SOUTH PADRE ISLAND
CONSENT AGENDA**

MEETING DATE: July 17, 2019

ITEM DESCRIPTION

NOTE: All matters listed under Consent Agenda are considered routine by the City Council of the City of South Padre Island and will be enacted by one motion. There will not be separate discussion of these items. If discussion is desired, that item will be removed from the Consent Agenda and considered separately.

Items to be considered are:

- a. Approve minutes of June 19, 2019 workshop and regular meeting, July 10, 2019 special meeting. (Manning)
- b. Approve invoices for payment. (Gimenez)
- c. Approve a budget amendment for \$7,000 for professional services to conduct Phase 2 (final phase) of the internal Municipal Court audit. (Vasquez/Delgado)
- d. Approve an excused absence for Council Member Kerry Schwartz from the July 10, 2019 special meeting. (Schwartz)
- e. Approve second and final reading of Ordinance No. 19-10 amending Chapter 4 by repealing and replacing Section 4-17 and 4-18 to provide regulations regarding substandard structures, create a review board to provide for public hearings and remediation regarding the same and dealing with related matters. (Hanley/Travis)

RECOMMENDATIONS/COMMENTS

Approve Consent Agenda

**CITY OF SOUTH PADRE ISLAND
CITY COUNCIL MEETING
AGENDA REQUEST FORM**

MEETING DATE: July 17, 2019

NAME & TITLE: Susan Manning, City Secretary

DEPARTMENT: City Manager's Office

ITEM

Approve the minutes of June 19, 2019 workshop and regular meeting, July 10, 2019 special meeting.

ITEM BACKGROUND

BUDGET/FINANCIAL SUMMARY

COMPREHENSIVE PLAN GOAL

LEGAL REVIEW

Sent to Legal: YES: _____ NO: _____
Approved by Legal: YES: _____ NO: _____

Comments:

RECOMMENDATIONS/COMMENTS

Approve Minutes

7-2

**MINUTES
CITY OF SOUTH PADRE ISLAND
CITY COUNCIL REGULAR MEETING**

WEDNESDAY, JUNE 19, 2019

I. CALL TO ORDER

The City Council Members of the City of South Padre Island, Texas held a Regular Meeting on Wednesday, June 19, 2019 at the Municipal Complex Building, 2nd Floor, 4601 Padre Boulevard, South Padre Island, Texas. Mayor Stahl called the meeting to order at 5:30 p.m. A full quorum was present: Mayor Dennis Stahl, Council Members Ken Medders, Jr., Kerry Schwartz, Joe Ricco, Alita Bagley and Eva-Jean Dalton.

City staff members present were City Manager Randy Smith, Chief Financial Officer Rodrigo Gimenez, Public Works Director Alex Sanchez, Administrative Services Director Wendi Delgado, Fire Chief Doug Fowler, Transit Director Jesse Arriaga, Shoreline Management Director Kristina Boburka, CVB Director Ed Caum, Planning Director Aaron Hanley, Assistant Public Works Director Jon Wilson, Information Technology Director Mark Shellard, Building Official David Travis, Police Lieutenant Juan Herrera, Public Information Officer Angelique Soto and City Secretary Susan Manning.

II. PLEDGE OF ALLEGIANCE AND TEXAS PLEDGE

Mayor Stahl led the Pledge of Allegiance.

III. PUBLIC COMMENTS AND ANNOUNCEMENTS

Public comments and announcements were given at this time.

4. PRESENTATIONS AND PROCLAMATIONS

None

5. APPROVE CONSENT AGENDA:

Council Member Bagley made a motion, seconded by Council Member Schwartz to approve the Consent Agenda. Motion carried on a unanimous vote.

A. APPROVE MINUTES OF JUNE 5, 2019 REGULAR MEETING AND JUNE 6, 2019 SPECIAL MEETING. (MANNING)

B. APPROVE INVOICES FOR PAYMENT. (GIMENEZ)

Invoices approved for payment were paid by General Fund checks numbered 144614 through 144753 and EFT payments totaling \$950,605.09.

C. APPROVE RESOLUTION NO. 2019-25 SUPPORTING THE SUBMISSION OF THE APPLICATION FOR STATE ASSISTANCE FROM THE BEACH MAINTENANCE REIMBURSEMENT FUND FOR THE FISCAL YEAR 2020. (BOBURKA)

A true and correct copy of said Resolution was placed in the City's Resolution Book and entitled Resolution No. 2019-25, and, by reference hereto, included in these Minutes as if fully set out and spread upon the pages of the Minutes Book.

D. APPROVE RESOLUTION NO. 2019-26 THAT ESTABLISHES RENTAL CHARGES FOR BEACH CLEANING EQUIPMENT AND LABOR TO BE USED FOR THE CITY'S BEACH MAINTENANCE REIMBURSEMENT SUBMISSIONS. (BOBURKA)

A true and correct copy of said Resolution was placed in the City's Resolution Book and entitled Resolution No. 2019-26, and, by reference hereto, included in these Minutes as if fully set out and spread upon the pages of the Minutes Book.

E. APPROVE A BUDGET AMENDMENT OF FEDERAL FORFEITURE FUNDS IN THE AMOUNT OF \$1,328 FOR TWO DEL TEC TACTICAL 40MM L.W. SINGLE LAUNCHER WEAPONS. (O'CARROLL)

F. APPROVE RESOLUTION NO. 2019-27 TO APPOINT CHRIS HUFFMAN AS THE EARLY VOTING BALLOT BOARD JUDGE FOR THE JUNE 29, 2019 RUNOFF ELECTION. (MANNING)

A true and correct copy of said Resolution was placed in the City's Resolution Book and entitled Resolution No. 2019-27, and, by reference hereto, included in these Minutes as if fully set out and spread upon the pages of the Minutes Book.

VI. DISCUSSION AND POSSIBLE ACTION TO DEDICATE THE NEW TRANSIT MULTIMODAL FACILITY TO FORMER MAYOR AND ALDERMAN, ROBERT N. PINKERTON, JR. (RICCO/STAHL)

Council Member Ricco made a motion to dedicate the new Transit Multimodal Facility to Robert N. Pinkerton, Jr., former Mayor and Alderman. Motion was seconded by Mayor Stahl, which carried unanimously.

VII. DISCUSSION AND POSSIBLE ACTION TO DIRECT THE INTERIM CITY MANAGER TO AUTHORIZE AND ENTER INTO CONTRACT THE RENTAL OF THE UNUSED OFFICE SPACE AT THE TRANSIT MULTIMODAL FACILITY. (RICCO/MEDDERS)

Council Member Ricco made a motion to instruct the Interim City Manager to authorize staff to make the unused office space at the multimodal facility available for lease to

transportation related businesses to the facility at fair market rate. Council Member Bagley seconded the motion, which passed on a unanimous vote.

VIII. UPDATE REGARDING THE ECONOMIC DEVELOPMENT CORPORATION (EDC) FEASIBILITY STUDY ON AN EMERGENCY CARE FACILITY. (SCHWARTZ)

This item was pulled.

IX. PRESENTATION, DISCUSSION AND POSSIBLE ACTION REGARDING THE LAGUNA BOULEVARD IMPROVEMENT PROJECT. (MEDDERS/SCHWARTZ)

Discussion was held, no action taken.

X. UPDATE REGARDING STREET PREVENTIVE MAINTENANCE PROGRAM. (SANCHEZ)

Public Works Director Alex Sanchez gave an update on the Street Preventive Maintenance Program.

XI. DISCUSSION AND POSSIBLE ACTION TO RELOCATE THE VISITOR'S/WELCOME CENTER TO THE TRANSIT MULTIMODAL FACILITY. (RICCO/MEDDERS)

Council Member Ricco made a motion, seconded by Council Member Dalton to approve the relocation of the Visitor's/Welcome Center to the Transit Multimodal Facility. Motion passed on a unanimous vote.

XII. DISCUSSION AND POSSIBLE ACTION TO DIRECT THE INTERIM CITY MANAGER TO SEEK BIDS FOR THE REDESIGN/REMODEL OF THE VISITOR CENTER BUILDING FOR A PARTIAL MUSEUM THAT WOULD ACCOMMODATE HISTORICAL ITEMS. (RICCO/BAGLEY)

Council Member Ricco made a motion to instruct staff to design and put out to bid and review the renovation of the interior of the north wing of Visitors Center to be used and dedicated to a historical museum. Museum performance would also be reevaluated after 24 months of grand opening. Council Member Bagley seconded the motion. Council Member Ricco amended the motion to include a contract with the museum, Council Member Bagley seconded the amendment. Motion carried unanimously.

XIII. PRESENTATION AND UPDATE REGARDING PROPOSED LIQUID NATURE GAS (LNG) PLANTS INCLUDING CURRENT FILINGS, FEDERAL ENERGY REGULATORY COMMISSION (FERC) ACTIONS, TEXAS COMMISSION ON ENVIRONMENTAL QUALITY (TCEQ) ACTIONS, AND CITY RESPONSE AND COMMUNICATIONS. (SCHWARTZ/SOTO)

Public Information Officer Nikki Soto gave a presentation on the Liquid Nature Gas (LNG) plants and other environmental related issues.

XIV. DISCUSSION AND ACTION TO APPROVE FIRST READING OF ORDINANCE NO. 19-10, CHAPTER 4, SECTION 4-17, STANDARD HOUSING CODE, BOARD OF ADJUSTMENTS AND APPEALS, AND SECTION 4-18, STANDARD UNSAFE BUILDING ABATEMENT CODE AND CHAPTER 214 OF THE LOCAL GOVERNMENT CODE. (HANLEY/TRAVIS)

Council Member Bagley made a motion to approve first reading of Ordinance No. 19-10. Council Member Ricco seconded the motion. Motion passed on a 4 to 0 to 0 vote with Mayor Stahl abstaining and Council Member Dalton momentarily stepping out of the Council Chambers.

XV. UPDATE, DISCUSSION AND ACTION TO PROCEED OR MAKE CHANGES TO THE PROPOSED PALM STREET BOAT RAMP AND SUNSET BEACH ACCESS PROJECTS. (BOBURKA)

Council Member Ricco made a motion, seconded by Council Member Bagley to table this item. Motion carried unanimously.

XVI. DISCUSSION AND ACTION TO ALLOW THE INTERIM CITY MANAGER TO AMEND THE AGREEMENT WITH THE UNITED STATES GEOLOGICAL SURVEY (USGS) TO INCREASE FUNDS FOR THE PARTICLE TRACING STUDY BY \$10,000 FOR INSTRUMENT RECOVERY. (BOBURKA)

Mayor Stahl made a motion to allow the Interim City Manager to amend the agreement the U.S. Geological Survey to increase the Particle Tracing Study in the amount of \$10,000 for instrument recovery. Motion was sec

XVII. EXECUTIVE SESSION: PURSUANT TO SECTIONS 551.074, PERSONNEL MATTERS; TO DELIBERATE THE APPOINTMENT, EMPLOYMENT, EVALUATION, REASSIGNMENT, DUTIES, DISCIPLINE, OR DISMISSAL OF A PUBLIC OFFICER OR EMPLOYEE, TO WIT, INTERIM CITY MANAGER RANDY SMITH.

At 7:49 p.m., Council Member Schwartz made a motion, seconded by Council Member Dalton to go into Executive Session. Motion carried unanimously.

At 8:07 p.m., the City Council reconvened into open session.

XVIII. CONSIDERATION AND ACTION TO APPOINT INTERIM CITY MANAGER, RANDY SMITH AS CITY MANAGER PURSUANT TO ARTICLE III OF THE CITY CHARTER FOR THE CITY OF SOUTH PADRE ISLAND. (CITY COUNCIL)

Council Member Dalton, made a motion, seconded by Council Member Ricco to appoint Randy Smith as the City Manager. Motion carried on a 5 to 0 vote with Council Member Bagley absent from the Council Chambers.

XIX. DISCUSSION AND ACTION TO EXECUTE A CONTRACT WITH NEW CITY MANAGER. (CITY COUNCIL)

Council Member Schwartz made a motion to execute a contract with the new City Manager. Motion was seconded by Council Member Medders, which passed on a 5 to 0 vote with Council Member Bagley absent from the Council Chambers.

XX. ADJOURN.

There being no further business, Mayor Stahl adjourned the meeting at 8:08 p.m.

Susan M. Manning, City Secretary

APPROVED

Dennis Stahl, Mayor

MINUTES CITY OF SOUTH PADRE ISLAND CITY COUNCIL SPECIAL MEETING
--

WEDNESDAY, JULY 10, 2019

I. CALL TO ORDER

The City Council Members of the City of South Padre Island, Texas held a Special Meeting on Wednesday, July 10, 2019 at the Municipal Complex Building, 2nd Floor, 4601 Padre Boulevard, South Padre Island, Texas. Mayor Stahl called the meeting to order at 3:00 p.m. A quorum was present: Mayor Dennis Stahl, Council Members Ken Medders, Jr., Joe Ricco, Alita Bagley and Eva-Jean Dalton. Absent was Council Member Kerry Schwartz.

City staff members present were City Manager Randy Smith, Chief Financial Officer Rodrigo Gimenez, Public Works Director Alex Sanchez, Environmental Health Director Victor Baldovinos, Shoreline Management Director Kristina Boburka, Assistant Public Works Director Jon Wilson, Information Technology Director Mark Shellard, Public Information Officer Angelique Soto and City Secretary Susan Manning.

II. PLEDGE OF ALLEGIANCE AND TEXAS PLEDGE

Mayor Stahl led the Pledge of Allegiance and the Texas Pledge.

III. PUBLIC COMMENTS AND ANNOUNCEMENTS

None.

IV. DISCUSSION AND ACTION TO APPROVE RESOLUTION NO. 2019-28 CANVASSING THE RETURNS AND DECLARING THE RESULTS OF THE JUNE 29, 2019 RUNOFF ELECTION FOR THE PURPOSE TO FILL A VACANCY IN THE UNEXPIRED TERM OF MAYOR. (MANNING)

Mayor Stahl made a motion, seconded by Council Member Ricco to approve Resolution No. 2019-28 canvassing the returns and declaring the results of the June 29, 2019 runoff election. Motion carried unanimously.

A true and correct copy of said Resolution was placed in the City’s Resolution Book and entitled Resolution No. 2019-28, and, by reference hereto, included in these Minutes as if fully set out and spread upon the pages of the Minutes Book.

Results of the runoff election are as follows:

Runoff Election—to fill a vacancy in the unexpired term of Mayor:

Candidates	Votes Cast Early	Votes Cast Election Day	Total

Patrick McNulty	325	163	488
Darla Jones	309	79	388

V. **DISCUSSION AND ACTION TO AUTHORIZE TO APPLY FOR THE BETTER UTILIZING INVESTMENTS TO LEVERAGE DEVELOPMENT OR “BUILD TRANSPORTATION GRANTS” AND APPROVE A LETTER OF COMMITMENT FOR THE TWENTY PERCENT MATCH. (SANCHEZ/MEDDERS)**

Council Member Medders made a motion to authorize staff to apply for the Better Utilizing Investments to Leverage Development grant and approve a Letter of Commitment for twenty percent for improvements to Laguna Boulevard. Motion carried unanimously.

VI. **ADJOURN.**

There being no further business, Mayor Stahl adjourned the meeting at 3:23 p.m.

Susan M. Manning, City Secretary

APPROVED

Dennis Stahl, Mayor

7-7

**MINUTES
CITY OF SOUTH PADRE ISLAND
CITY COUNCIL WORKSHOP**

WEDNESDAY, JUNE 19, 2019

I. Call to order

The City Council Members of the City of South Padre Island, Texas held a workshop on Wednesday, June 19, 2019 at the Municipal Complex Building, 2nd Floor, 4601 Padre Boulevard, South Padre Island, Texas. Mayor Stahl called the meeting to order at 3:00 p.m. A full quorum was present: Mayor Dennis Stahl, Council Members Ken Medders, Jr., Kerry Schwartz, Joe Ricco, Alita Bagley and Eva-Jean Dalton.

City staff members present were City Manager Randy Smith, Chief Financial Officer Rodrigo Gimenez, Public Works Director Alex Sanchez, Administrative Services Director Wendi Delgado, Fire Chief Doug Fowler, Transit Director Jesse Arriaga, Shoreline Management Director Kristina Boburka, Planning Director Aaron Hanley, Assistant Public Works Director Jon Wilson, Information Technology Director Mark Shellard, Building Official David Travis, Police Sergeant Gilbert Silva, Public Information Officer Angelique Soto and City Secretary Susan Manning.

II. PLEDGE OF ALLEGIANCE

Mayor Stahl led the Pledge of Allegiance.

III. PUBLIC COMMENTS AND ANNOUNCEMENTS

None

IV. DISCUSSION REGARDING FISCAL YEAR 2019-20 BUDGET. (GIMENEZ)

- a. **GENERAL FUND (FUND 01)**
- b. **VENUE TAX (FUND 03)**
- c. **PARKS, RECREATION & BEAUTIFICATION (FUND 09)**
- d. **MUNICIPAL COURT TECHNOLOGY (FUND 21)**
- e. **MUNICIPAL COURT SECURITY (FUND 22)**
- f. **TRANSPORTATION FUND (FUND 30)**
- g. **GENERAL DEBT SERVICE (FUND 50)**
- h. **TIRZ – TAX INCREMENT REINVESTMENT ZONE (FUND 51)**
- i. **VENUE DEBT SERVICE (FUND 53)**
- j. **VENUE TAX CONSTRUCTION (FUND 57)**
- k. **BEACH MAINTENANCE (FUND 60)**
- l. **BEACH ACCESS (FUND 61)**
- m. **CAPITAL REPLACEMENT (FUND 65)**
- n. **BEACH NOURISHMENT (FUND 81)**

Chief Financial Officer Rodrigo Gimenez gave an overview of the budget process, budget highlights which included General Fund Surplus of \$48,000, Replacement Programs in place for computers, vehicles and preventative maintenance and an increase of 3/9% in preliminary taxable values. Also addressed were all other funds excluding Hotel/Motel Occupancy Tax and Convention Centre funds.

V. **ADJOURN.**

There being no further discussion, Mayor Stahl adjourned the workshop at 3:28 p.m.

Susan M. Manning, City Secretary

APPROVED

Dennis Stahl, Mayor

**CITY OF SOUTH PADRE ISLAND
CITY COUNCIL MEETING
AGENDA REQUEST FORM**

MEETING DATE: July 17, 2019

NAME & TITLE: Rodrigo Gimenez, Chief Financial Officer

DEPARTMENT: Finance Department

ITEM

Approve invoices for payment by General Fund checks numbered 144754 through 144964 and EFT payments totaling \$1,010,917.47.

ITEM BACKGROUND

BUDGET/FINANCIAL SUMMARY

COMPREHENSIVE PLAN GOAL

LEGAL REVIEW

Sent to Legal: YES: _____ NO: _____
Approved by Legal: YES: _____ NO: _____

Comments:

RECOMMENDATIONS/COMMENTS

Approve payments.

7/10/2019 6:47 PM

REGULAR DEPARTMENT PAYMENT REPORT

PAGE: 1

VENDOR SET: 01 City of South Padre Islan

BANK: OPER

FUND : 01 GENERAL FUND

DEPARTMENT: N/A NON-DEPARTMENTAL

INVOICE DATE RANGE: 1/01/1998 THRU 99/99/9999

PAY DATE RANGE: 6/20/2019 THRU 7/12/2019

BUDGET TO USE: CB-CURRENT BUDGET

VENDOR	NAME	ITEM #	G/L	ACCOUNT	NAME	DESCRIPTION	CHECK #	AMOUNT
01-002434	CINDY BOUDLOCHE	I-DWE201906256453	01	2469	DEBTORS WAGE :	CASE NO 16-10432	144813	1,492.15
01-002434	CINDY BOUDLOCHE	I-DWE201907096460	01	2469	DEBTORS WAGE :	CASE NO 16-10432	144916	1,492.15
							VENDOR 01-002434 TOTALS	2,984.30
01-003035	CALIFORNIA STATE DISBU	I-C2X201906256453	01	2473	CHILD SUPPORT:	ORDER NO 0890195390	144815	219.23
01-003035	CALIFORNIA STATE DISBU	I-C2X201907096460	01	2473	CHILD SUPPORT:	ORDER NO 0890195390	144919	219.23
							VENDOR 01-003035 TOTALS	438.46
01-003185	OFFICE OF THE ATTY GEN	I-C10201906256453	01	2473	CHILD SUPPORT:	A/N 20040948648	001125	364.15
01-003185	OFFICE OF THE ATTY GEN	I-C10201907096460	01	2473	CHILD SUPPORT:	A/N 20040948648	001263	364.15
01-003185	OFFICE OF THE ATTY GEN	I-C1C201906256453	01	2473	CHILD SUPPORT:	ORDER NO 2015-DCL-56	001125	339.23
01-003185	OFFICE OF THE ATTY GEN	I-C1C201907096460	01	2473	CHILD SUPPORT:	ORDER NO 2015-DCL-56	001263	339.23
01-003185	OFFICE OF THE ATTY GEN	I-C1Q201906256453	01	2473	CHILD SUPPORT:	CS 2014-DCL-08362	001125	191.54
01-003185	OFFICE OF THE ATTY GEN	I-C1Q201907096460	01	2473	CHILD SUPPORT:	CS 2014-DCL-08362	001263	191.54
01-003185	OFFICE OF THE ATTY GEN	I-C1R201906256453	01	2473	CHILD SUPPORT:	ORDER NO 08-1471	001125	429.23
01-003185	OFFICE OF THE ATTY GEN	I-C1R201907096460	01	2473	CHILD SUPPORT:	ORDER NO 08-1471	001263	429.23
01-003185	OFFICE OF THE ATTY GEN	I-C21201906256453	01	2473	CHILD SUPPORT:	A/N 0011549506	001125	369.23
01-003185	OFFICE OF THE ATTY GEN	I-C21201907096460	01	2473	CHILD SUPPORT:	A/N 0011549506	001263	369.23
01-003185	OFFICE OF THE ATTY GEN	I-C24201906256453	01	2473	CHILD SUPPORT:	A/N 0011488748	001125	259.28
01-003185	OFFICE OF THE ATTY GEN	I-C24201907096460	01	2473	CHILD SUPPORT:	A/N 0011488748	001263	259.28
01-003185	OFFICE OF THE ATTY GEN	I-C2W201906256453	01	2473	CHILD SUPPORT:	CASE ID 0012479628	001125	189.23
01-003185	OFFICE OF THE ATTY GEN	I-C2W201907096460	01	2473	CHILD SUPPORT:	CASE ID 0012479628	001263	189.23
01-003185	OFFICE OF THE ATTY GEN	I-C3K201907096460	01	2473	CHILD SUPPORT:	ORDER 2012-DC3-00202	001263	256.15
01-003185	OFFICE OF THE ATTY GEN	I-C51201906256453	01	2473	CHILD SUPPORT:	A/N 0012375322	001125	294.33
01-003185	OFFICE OF THE ATTY GEN	I-C51201907096460	01	2473	CHILD SUPPORT:	A/N 0012375322	001263	294.33
01-003185	OFFICE OF THE ATTY GEN	I-C77201906256453	01	2473	CHILD SUPPORT:	A/N 0010353126	001125	159.23
01-003185	OFFICE OF THE ATTY GEN	I-C77201907096460	01	2473	CHILD SUPPORT:	A/N 0010353126	001263	159.23
01-003185	OFFICE OF THE ATTY GEN	I-C82201906256453	01	2473	CHILD SUPPORT:	ORDER #2012-DCL-0866	001125	410.77
01-003185	OFFICE OF THE ATTY GEN	I-C82201907096460	01	2473	CHILD SUPPORT:	ORDER #2012-DCL-0866	001263	410.77
01-003185	OFFICE OF THE ATTY GEN	I-C91201906256453	01	2473	CHILD SUPPORT:	AG 0012920905	001125	296.77
01-003185	OFFICE OF THE ATTY GEN	I-C91201907096460	01	2473	CHILD SUPPORT:	AG 0012920905	001263	296.77
01-003185	OFFICE OF THE ATTY GEN	I-C93201906256453	01	2473	CHILD SUPPORT:	ORDER # 99125207D	001125	101.54
01-003185	OFFICE OF THE ATTY GEN	I-C93201907096460	01	2473	CHILD SUPPORT:	ORDER # 99125207D	001263	101.54
01-003185	OFFICE OF THE ATTY GEN	I-C95201906256453	01	2473	CHILD SUPPORT:	CASE #0013025749	001125	420.00
01-003185	OFFICE OF THE ATTY GEN	I-C95201907096460	01	2473	CHILD SUPPORT:	CASE #0013025749	001263	420.00
							VENDOR 01-003185 TOTALS	7,905.21
01-003444	CITIBANK	I-60319	01	2489	PURCHASING CA:	MAY 2019 P CARD PURC	144805	75,348.13
							VENDOR 01-003444 TOTALS	75,348.13

7/10/2019 6:47 PM

REGULAR DEPARTMENT PAYMENT REPORT

PAGE: 2

VENDOR SET: 01 City of South Padre Islan

BANK: OPER

FUND : 01 GENERAL FUND

DEPARTMENT: N/A NON-DEPARTMENTAL

INVOICE DATE RANGE: 1/01/1998 THRU 99/99/9999

PAY DATE RANGE: 6/20/2019 THRU 7/12/2019

BUDGET TO USE: CB-CURRENT BUDGET

VENDOR	NAME	ITEM #	G/L	ACCOUNT	NAME	DESCRIPTION	CHECK #	AMOUNT
01-006133	DEARBORN NATIONAL	I-62519	01	2465	VTL LIFE INSU:	EMPLOYEE PREMIUMS -	144824	60.35
01-006133	DEARBORN NATIONAL	I-62519	01	48042	MISCELLANEOUS:	EMPLOYEE PREMIUMS -	144824	0.02-
							VENDOR 01-006133 TOTALS	60.33
01-006163	AMERICAN GENERAL LIFE	I-62519	01	2485	AMERICAN GENE:	EMPLOYEE SALARY ALLO	144825	117.76
							VENDOR 01-006163 TOTALS	117.76
01-007001	ANA GARZA	I-C04201906256453	01	2473	CHILD SUPPORT:	A/N 2003-03-1480-B	144827	194.88
01-007001	ANA GARZA	I-C04201907096460	01	2473	CHILD SUPPORT:	A/N 2003-03-1480-B	144930	194.88
							VENDOR 01-007001 TOTALS	389.76
01-019222	S.P.I. FIREFIGHTERS AS	I-62519	01	2472	FIREFIGHTERS :	ASSOCIATION DUES 6/2	144851	377.00
01-019222	S.P.I. FIREFIGHTERS AS	I-70919	01	2472	FIREFIGHTERS :	ASSOCIATION DUES 7/1	144948	377.00
							VENDOR 01-019222 TOTALS	754.00
01-019327	SOUTH PADRE ISLAND PRO	I-62519	01	2487	POLICE DEPT A:	ASSOCIATION DUES 6/2	000283	75.00
01-019327	SOUTH PADRE ISLAND PRO	I-70919	01	2487	POLICE DEPT A:	ASSOCIATION DUES 7/1	000303	75.00
							VENDOR 01-019327 TOTALS	150.00
01-020057	TML MULTISTATE IEBP	I-070119	01	2461	TML MEDICAL :	JULY 2019 MEDICAL PR	000289	15,323.00
01-020057	TML MULTISTATE IEBP	I-070119	01	2484	VISION :	JULY 2019 MEDICAL PR	000289	486.00
							VENDOR 01-020057 TOTALS	15,809.00
01-020700	TRANSAMERICA WORKSITE	I-62519	01	2464	TRANSAMERICA :	EMPLOYEE PREMIUMS JU	144858	15.18
01-020700	TRANSAMERICA WORKSITE	I-62519	01	48042	MISCELLANEOUS:	EMPLOYEE PREMIUMS JU	144858	0.01-
							VENDOR 01-020700 TOTALS	15.17
01-021226	US BANK VOYAGER FLEET	I-869326488926	01	48090	FUEL REBATE :	FUEL PURCHASED MAY 2	144909	1,429.02-
							VENDOR 01-021226 TOTALS	1,429.02-

7/10/2019 6:47 PM

REGULAR DEPARTMENT PAYMENT REPORT

PAGE: 3

VENDOR SET: 01 City of South Padre Islan

BANK: OPER

FUND : 01 GENERAL FUND

DEPARTMENT: N/A NON-DEPARTMENTAL

INVOICE DATE RANGE: 1/01/1998 THRU 99/99/9999

PAY DATE RANGE: 6/20/2019 THRU 7/12/2019

BUDGET TO USE: CB-CURRENT BUDGET

VENDOR	NAME	ITEM #	G/L ACCOUNT	NAME	DESCRIPTION	CHECK #	AMOUNT
01-022249	VICTOR O. SCHINNERER &	I-SI752781	01 1400	PREPAID EXPEN:	WINDSTORM POL 7/02/1	144804	64,152.57
						VENDOR 01-022249 TOTALS	64,152.57
01-1	HUERTA, ALBERTO	I-000201906126441	01 2424	MUN. COURT BO:	Bond Refund:43931A	144789	270.00
01-1	RODRIGUEZ, VICTOR MANU	I-000201906126442	01 2424	MUN. COURT BO:	Bond Refund:43933A	144790	270.00
01-1	CEPEDA, AMADA S	I-000201906126443	01 2424	MUN. COURT BO:	Bond Refund:E0057836	144791	230.00
01-1	WALSH, SARAH MARIE	I-000201906126444	01 2424	MUN. COURT BO:	Bond Refund:43869A	144792	370.00
01-1	RAMIREZ, JENNA MARIE	I-000201906126445	01 2424	MUN. COURT BO:	Bond Refund:43952A	144793	94.50
01-1	RAMIREZ, JENNA MARIE	I-000201906126445	01 2424	MUN. COURT BO:	Bond Refund:43952A	144793	175.50
01-1	DELACRUZ, DAYCI LILLIA	I-000201906126446	01 2424	MUN. COURT BO:	Bond Refund:43955A	144794	270.00
01-1	BROOKS, BRAYTON	I-000201906126447	01 2424	MUN. COURT BO:	Bond Refund:44023A	144795	270.00
01-1	ORTIZ, SERGIO	I-000201906126448	01 2424	MUN. COURT BO:	Bond Refund:44013A	144796	270.00
01-1	ALVAREZ, DYLAN ANTHONY	I-000201906126449	01 2424	MUN. COURT BO:	Bond Refund:44107A	144797	270.00
01-1	BORDERS, JACOB ETHAN	I-000201906126450	01 2424	MUN. COURT BO:	Bond Refund:44075A	144798	270.00
01-1	NAVARRO, ALYSSA RENE	I-000201906126451	01 2424	MUN. COURT BO:	Bond Refund:44162A	144799	370.00
						VENDOR 01-1 TOTALS	3,130.00
			DEPARTMENT	NON-DEPARTMENTAL	TOTAL:		169,825.67

7/10/2019 6:47 PM

REGULAR DEPARTMENT PAYMENT REPORT

PAGE: 4

VENDOR SET: 01 City of South Padre Islan

BANK: OPER

FUND : 01 GENERAL FUND

DEPARTMENT: 511 CITY COUNCIL

INVOICE DATE RANGE: 1/01/1998 THRU 99/99/9999

PAY DATE RANGE: 6/20/2019 THRU 7/12/2019

BUDGET TO USE: CB-CURRENT BUDGET

VENDOR	NAME	ITEM #	G/L ACCOUNT	NAME	DESCRIPTION	CHECK #	AMOUNT
01-003410	SPI CHAMBER OF COMMERC	I-13467	01 511-0550-034	KERRY SCHWART	QTRLY PUBLIC AFFAIRS	144759	20.00
01-003410	SPI CHAMBER OF COMMERC	I-13467	01 511-0550-033	JOE RICCO	: QTRLY PUBLIC AFFAIRS	144759	20.00
						VENDOR 01-003410 TOTALS	40.00

DEPARTMENT 511 CITY COUNCIL TOTAL: 40.00

7/10/2019 6:47 PM

REGULAR DEPARTMENT PAYMENT REPORT

PAGE: 5

VENDOR SET: 01 City of South Padre Island

BANK: OPER

FUND : 01 GENERAL FUND

DEPARTMENT: 512 CITY MANAGERS OFFICE

INVOICE DATE RANGE: 1/01/1998 THRU 99/99/9999

PAY DATE RANGE: 6/20/2019 THRU 7/12/2019

BUDGET TO USE: CB-CURRENT BUDGET

VENDOR	NAME	ITEM #	G/L ACCOUNT	NAME	DESCRIPTION	CHECK #	AMOUNT
01-002068	JULIANNA R. BARRON	I-070119	01 512-0550	TRAVEL EXPENS:	MILEAGE FOR RT TO BR	000300	34.68
VENDOR 01-002068 TOTALS							34.68
01-007053	RODRIGO GIMENEZ	I-061319	01 512-0550	TRAVEL EXPENS:	PER DIEM: TCMA JUNE	000275	120.00
01-007053	RODRIGO GIMENEZ	I-70119-1	01 512-0550	TRAVEL EXPENS:	REIMBURSE FOR GRN TR	000301	116.58
VENDOR 01-007053 TOTALS							236.58
01-019189	WILLIAM R. SMITH	I-61319	01 512-0550	TRAVEL EXPENS:	PER DIEM TCMA-DALLAS	144779	240.00
VENDOR 01-019189 TOTALS							240.00
01-020057	TML MULTISTATE IEBP	I-070119	01 512-0081	GROUP INSURAN:	JULY 2019 MEDICAL PR	000289	2,139.70
VENDOR 01-020057 TOTALS							2,139.70
01-020602	TOUCAN GRAPHICS	I-27221	01 512-0101	OFFICE SUPPLI:	500 BUS. CARDS. R. S	144955	39.00
VENDOR 01-020602 TOTALS							39.00

DEPARTMENT 512 CITY MANAGERS OFFICE TOTAL: 2,689.96

7/10/2019 6:47 PM

REGULAR DEPARTMENT PAYMENT REPORT

PAGE: 6

VENDOR SET: 01 City of South Padre Island

BANK: OPER

FUND : 01 GENERAL FUND

DEPARTMENT: 513 FINANCE DEPARTMENT

INVOICE DATE RANGE: 1/01/1998 THRU 99/99/9999

PAY DATE RANGE: 6/20/2019 THRU 7/12/2019

BUDGET TO USE: CB-CURRENT BUDGET

VENDOR	NAME	ITEM #	G/L ACCOUNT	NAME	DESCRIPTION	CHECK #	AMOUNT
01-007053	RODRIGO GIMENEZ	I-041819-1	01 513-0550	TRAVEL EXPENS:	MILEAGE RT SAN ANTON	000301	337.56
01-007053	RODRIGO GIMENEZ	I-41819-1	01 513-0550	TRAVEL EXPENS:	PER DIEM, SAN ANTONI	000301	162.00
						VENDOR 01-007053 TOTALS	499.56
01-007154	GOVERNMENT FINANCE OFF	I-0132021	01 513-0551	DUES & MEMBER:	MEMBERSHIP: MARIA HE	144768	150.00
01-007154	GOVERNMENT FINANCE OFF	I-0136006-19	01 513-0551	DUES & MEMBER:	MEMBERSHIP RENEWAL:	144768	170.00
						VENDOR 01-007154 TOTALS	320.00
01-019638	TEXAS COMPTROLLER OF P	I-7519	01 513-0551	DUES & MEMBER:	TX CO-OP MEMBERSHIP	144951	100.00
						VENDOR 01-019638 TOTALS	100.00
01-020057	TML MULTISTATE IEBP	1-070119	01 513-0081	GROUP INSURAN:	JULY 2019 MEDICAL PR	000289	2,490.07
						VENDOR 01-020057 TOTALS	2,490.07
						DEPARTMENT 513 FINANCE DEPARTMENT TOTAL:	3,409.63

7/10/2019 6:47 PM

REGULAR DEPARTMENT PAYMENT REPORT

PAGE: 7

VENDOR SET: 01 City of South Padre Island

BANK: OPER

FUND : 01 GENERAL FUND

DEPARTMENT: 514 PLANNING DEPARTMENT

INVOICE DATE RANGE: 1/01/1998 THRU 99/99/9999

PAY DATE RANGE: 6/20/2019 THRU 7/12/2019

BUDGET TO USE: CB-CURRENT BUDGET

VENDOR	NAME	ITEM #	G/L ACCOUNT	NAME	DESCRIPTION	CHECK #	AMOUNT
01-020057	TML MULTISTATE IEBP	I-070119	01 514-0081	GROUP INSURAN:	JULY 2019 MEDICAL PR	000289	1,041.08
						VENDOR 01-020057 TOTALS	1,041.08

DEPARTMENT 514 PLANNING DEPARTMENT TOTAL: 1,041.08

7/10/2019 6:47 PM

REGULAR DEPARTMENT PAYMENT REPORT

PAGE: 8

VENDOR SET: 01 City of South Padre Islan

BANK: OPER

FUND : 01 GENERAL FUND

DEPARTMENT: 515 TECHNOLOGY DEPARTMENT

INVOICE DATE RANGE: 1/01/1998 THRU 99/99/9999

PAY DATE RANGE: 6/20/2019 THRU 7/12/2019

BUDGET TO USE: CB-CURRENT BUDGET

VENDOR	NAME	ITEM #	G/L ACCOUNT	NAME	DESCRIPTION	CHECK #	AMOUNT
01-004089	DEPT OF INFO RESOURCES	I-19050601N	01 515-0501	COMMUNICATION:	TEX-ANNG CHRGS, MAY 000278		4.47
					VENDOR 01-004089 TOTALS		4.47
01-009016	INSPECT2GO, INC	I-191105	01 515-0415	SERVICE CONTR:	2 YEAR SERVICE PLAN. 144880		4,000.00
					VENDOR 01-009016 TOTALS		4,000.00
01-009220	IWORQ SYSTEMS INC.	I-10813	01 515-0415	SERVICE CONTR:	INTERNET MGM.APPL. C 144883		1,500.00
01-009220	IWORQ SYSTEMS INC.	I-10831	01 515-0415	SERVICE CONTR:	INTERNETWORK MGMT FA 144883		1,440.00
					VENDOR 01-009220 TOTALS		2,940.00
01-019539	STW, INC.	I-25976	01 515-0415	SERVICE CONTR:	OPENGOV OPERATIONAL 144950		11,463.00
					VENDOR 01-019539 TOTALS		11,463.00
01-020057	TML MULTISTATE IEBP	I-070119	01 515-0081	GROUP INSURAN:	JULY 2019 MEDICAL PR 000289		1,571.62
					VENDOR 01-020057 TOTALS		1,571.62
01-020185	TIME WARNER CABLE	I-0213755062019	01 515-0415	SERVICE CONTR:	INTERNET/CABLE FIRE 144898		412.32
					VENDOR 01-020185 TOTALS		412.32
01-020644	T-MOBILE	I-61519	01 515-0501	COMMUNICATION:	DATA SERVICE 144903		1,509.12
					VENDOR 01-020644 TOTALS		1,509.12
01-023034	WATCH GUARD, INC.	I-480INV0004857	01 515-0415	SERVICE CONTR:	4RE REMOTE SYST. SET 144785		750.00
					VENDOR 01-023034 TOTALS		750.00

DEPARTMENT 515 TECHNOLOGY DEPARTMENT TOTAL: 22,650.53

7/10/2019 6:47 PM

REGULAR DEPARTMENT PAYMENT REPORT

PAGE: 9

VENDOR SET: 01 City of South Padre Island

BANK: OPER

FUND : 01 GENERAL FUND

DEPARTMENT: 516 HUMAN RESOURCES

INVOICE DATE RANGE: 1/01/1998 THRU 99/99/9999

PAY DATE RANGE: 6/20/2019 THRU 7/12/2019

BUDGET TO USE: CB-CURRENT BUDGET

VENDOR	NAME	ITEM #	G/L ACCOUNT	NAME	DESCRIPTION	CHECK #	AMOUNT
01-002068	JULIANNA R. BARRON	I-62519	01 516-0514	TUITION ASSIS:	EDUCATION ASSISTANCE	000300	2,500.00
VENDOR 01-002068 TOTALS							2,500.00
01-004048	DEER OAKS EAP SERVICES	I-COSPI19-06	01 516-0530	PROFESSIONAL :	167 JUNE 2019 EAP SE	144820	150.30
VENDOR 01-004048 TOTALS							150.30
01-020057	TML MULTISTATE IEBP	I-070119	01 516-0081	GROUP INSURAN:	JULY 2019 MEDICAL PR	000289	1,448.99
VENDOR 01-020057 TOTALS							1,448.99
01-022037	C.L. ANDERSON, JR. M.D	I-699647	01 516-0530	PROFESSIONAL :	PHYSICALS & SCREENIN	144784	210.00
VENDOR 01-022037 TOTALS							210.00

DEPARTMENT 516 HUMAN RESOURCES TOTAL: 4,309.29

7/10/2019 6:47 PM

REGULAR DEPARTMENT PAYMENT REPORT

PAGE: 10

VENDOR SET: 01 City of South Padre Island

BANK: OPER

FUND : 01 GENERAL FUND

DEPARTMENT: 520 MUNICIPAL COURT

INVOICE DATE RANGE: 1/01/1998 THRU 99/99/9999

PAY DATE RANGE: 6/20/2019 THRU 7/12/2019

BUDGET TO USE: CB-CURRENT BUDGET

VENDOR	NAME	ITEM #	G/L ACCOUNT	NAME	DESCRIPTION	CHECK #	AMOUNT
01-004101	STUART J. DIAMOND	I-70119	01 520-0530	PROFESSIONAL	PROF. SERV. 2018-19	000290	1,335.00
VENDOR 01-004101 TOTALS							1,335.00
01-013410	MUNICIPAL SERVICES BUR I-738868		01 520-0531	WARRANT COLLE:	APRIL MUNICIPAL COLL 144839		1,108.90
01-013410	MUNICIPAL SERVICES BUR I-743045		01 520-0531	WARRANT COLLE:	MAY MUNICIAPAL COLLE 144840		428.21
VENDOR 01-013410 TOTALS							1,537.11
01-020057	TML MULTISTATE IEBP	I-670119	01 520-0081	GROUP INSURAN:	JULY 2019 MEDICAL PR 000289		2,602.70
VENDOR 01-020057 TOTALS							2,602.70
DEPARTMENT 520 MUNICIPAL COURT						TOTAL:	5,474.81

7/10/2019 6:47 PM

REGULAR DEPARTMENT PAYMENT REPORT

PAGE: 11

VENDOR SET: 01 City of South Padre Islan
FUND : 01 GENERAL FUND

BANK: OPER

DEPARTMENT: 521 POLICE DEPARTMENT
INVOICE DATE RANGE: 1/01/1998 THRU 99/99/9999
PAY DATE RANGE: 6/20/2019 THRU 7/12/2019
BUDGET TO USE: CB-CURRENT BUDGET

VENDOR	NAME	ITEM #	G/L ACCOUNT	NAME	DESCRIPTION	CHECK #	AMOUNT
01-001175	A-PRO TOWING & RECOVER	I-06171901	01 521-0530	PROFESSIONAL :	TOWED VEH. HEB PI TO	144915	185.00
						VENDOR 01-001175 TOTALS	185.00
01-001356	ARMAMENT SYSTEMS & PRO	I-0386305-IN	01 521-0150	MINOR TOOLS & :	PD-14 TALON BATONS	144756	1,053.50
						VENDOR 01-001356 TOTALS	1,053.50
01-002702	MARY ANN PERALEZ	I-1648	01 521-0415	SERVICE CONTR:	SERVICES FOR JULY -	144867	2,500.00
						VENDOR 01-002702 TOTALS	2,500.00
01-007006	GT DISTRIBUTORS, INC.	I-INV0713729	01 521-0130	WEARING APPAREL		144767	1,065.24
01-007006	GT DISTRIBUTORS, INC.	I-INV0714268	01 521-0130	WEARING APPAREL		144767	562.80
01-007006	GT DISTRIBUTORS, INC.	I-INV0715444	01 521-0130	WEARING APPAR:	3- BLACKINGTON CUSTO	144874	89.28
						VENDOR 01-007006 TOTALS	1,717.32
01-009106	INTL ASSC OF CHIEFS OF	I-0068175	01 521-0551	DUES & MEMBER:	RANDY SMITH, MEMBERS	144771	95.00
						VENDOR 01-009106 TOTALS	95.00
01-015010	OFFICE DEPOT	I-289721273001	01 521-0101	OFFICE SUPPLI:	1- BLK HP TONER	144888	147.17
						VENDOR 01-015010 TOTALS	147.17
01-016608	PORT ISABEL ANIMAL CLI	I-12612	01 521-0110	K9 SUPPLIES :	SURGERY CHARGES FOR	144889	727.11
						VENDOR 01-016608 TOTALS	727.11
01-020057	TML MULTISTATE IEBP	I-070113	01 521-0081	GROUP INSURAN:	JULY 2019 MEDICAL PR	000289	18,404.48
						VENDOR 01-020057 TOTALS	18,404.48
01-023058	WHATABURGER	I-1200032	01 521-0571	FOOD FOR PRIS:	PRISONER MEAL	144786	6.24
01-023058	WHATABURGER	I-1200100	01 521-0571	FOOD FOR PRIS:	PRISONER MEAL	144786	4.64
01-023058	WHATABURGER	I-1200136	01 521-0571	FOOD FOR PRIS:	PRISONER MEALS	144786	19.02
01-023058	WHATABURGER	I-1200138	01 521-0571	FOOD FOR PRIS:	PRISONER MEAL	144786	4.64

7/10/2019 6:47 PM

REGULAR DEPARTMENT PAYMENT REPORT

PAGE: 12

VENDOR SET: 01 City of South Padre Islan

BANK: OPER

FUND : 01 GENERAL FUND

DEPARTMENT: 521 POLICE DEPARTMENT

INVOICE DATE RANGE: 1/01/1998 THRU 99/99/9999

PAY DATE RANGE: 6/20/2019 THRU 7/12/2019

BUDGET TO USE: CB-CURRENT BUDGET

VENDOR	NAME	ITEM #	G/L ACCOUNT	NAME	DESCRIPTION	CHECK #	AMOUNT
01-023058	WHATABURGER	I-1200144	01 521-0571	FOOD FOR PRIS:	PRISONER MEALS	144786	13.92
01-023058	WHATABURGER	I-2287042	01 521-0571	FOOD FOR PRIS:	PRISONER MEAL	144786	6.34
01-023058	WHATABURGER	I-2289679	01 521-0571	FOOD FOR PRIS:	PRISONER MEALS	144786	9.28
						VENDOR 01-023058 TOTALS	64.08
01-1	GULF DATA PRODUCTS	I-109657	01 521-0101	OFFICE SUPPLI:	GULF DATA PRODUCTS:P	144911	118.95
						VENDOR 01-1 TOTALS	118.95
						DEPARTMENT 521 POLICE DEPARTMENT TOTAL:	25,012.61

7/10/2019 6:47 PM

REGULAR DEPARTMENT PAYMENT REPORT

PAGE: 13

VENDOR SET: 01 City of South Padre Island

BANK: OPER

FUND : 01 GENERAL FUND

DEPARTMENT: 522 FIRE DEPARTMENT

INVOICE DATE RANGE: 1/01/1998 THRU 99/99/9999

PAY DATE RANGE: 6/20/2019 THRU 7/12/2019

BUDGET TO USE: CB-CURRENT BUDGET

VENDOR	NAME	ITEM #	G/L	ACCOUNT	NAME	DESCRIPTION	CHECK #	AMOUNT
01-002439	BOUND TREE MEDICAL, LLC	I-62931180	01	522-0114	MEDICAL SUPPL:	IV DRESSING, MIS C. E	144814	416.15
01-002439	BOUND TREE MEDICAL, LLC	I-62975057	01	522-0114	MEDICAL SUPPL:	MISC. IV CATH, SYRIN	144814	472.34
01-002439	BOUND TREE MEDICAL, LLC	I-62975058	01	522-0114	MEDICAL SUPPL:	15 CS CURAPLEX HCT P	144814	20.85
01-002439	BOUND TREE MEDICAL, LLC	I-62994970	01	522-0114	MEDICAL SUPPL:	IV FLUSH SYR., ETC E	144814	441.00
01-002439	BOUND TREE MEDICAL, LLC	I-63032850	01	522-0114	MEDICAL SUPPL:	1-CS ELECTRODES,	144814	420.00
01-002439	BOUND TREE MEDICAL, LLC	I-63035783	01	522-0114	MEDICAL SUPPL:	10 BX LABETALOL, 3,	144814	443.90
01-002439	BOUND TREE MEDICAL, LLC	I-63036071	01	522-0114	MEDICAL SUPPL:	1 BX C4 MIDALZOLAM	144814	42.74
01-002439	BOUND TREE MEDICAL, LLC	I-83258899	01	522-0114	MEDICAL SUPPL:	1 BX ROCURONIUM 10MG	144917	204.85
							VENDOR 01-002439 TOTALS	2,461.83
01-003444	CITIBANK	I-60319	01	522-0411	BUILDING & ST:	OVERCHARGED	144805	173.00-
							VENDOR 01-003444 TOTALS	173.00-
01-003905	CULLIGAN WATER	I-800554812	01	522-0415	SERVICE CONTR:	200 # SOLAR SALT DEL	144923	41.00
							VENDOR 01-003905 TOTALS	41.00
01-006720	GABRIEL IVAN NAJERA	I-061719	01	522-0411	BUILDING & ST:	SERV. CALL DOOR 3 CA	144826	325.00
01-006720	GABRIEL IVAN NAJERA	I-61719	01	522-0411	BUILDING & ST:	SERVICE CALL, DOOR 2	144826	75.00
01-006720	GABRIEL IVAN NAJERA	I-62619	01	522-0411	BUILDING & ST:	REPLACE MTR CIRCUIT	144873	450.00
							VENDOR 01-006720 TOTALS	850.00
01-007075	GALLS, LLC	I-012941154	01	522-0130	WEARING APPAR:	2- TACLITE SHORTS	144875	100.97
							VENDOR 01-007075 TOTALS	100.97
01-007600	GULF COAST PAPER CO. I	I-1681479	01	522-0101	OFFICE SUPPLI:	PAPER TWLS, COPY PAP	144932	36.90
01-007600	GULF COAST PAPER CO. I	I-1681479	01	522-0160	LAUNDRY & JAN:	PAPER TWLS, COPY PAP	144932	136.22
01-007600	GULF COAST PAPER CO. I	I-1699131	01	522-0101	OFFICE SUPPLI:	1 CS COPY PAPER	144932	36.90
01-007600	GULF COAST PAPER CO. I	I-1699131	01	522-0160	LAUNDRY & JAN:	2 CS. PAPER TOWELS	144932	42.28
							VENDOR 01-007600 TOTALS	252.30
01-008313	HENRY SCHEIN INC	I-65895495	01	522-0114	MEDICAL SUPPL:	1- KETAMINE HCL INJ.	144831	50.40
01-008313	HENRY SCHEIN INC	I-65895514	01	522-0114	MEDICAL SUPPL:	2- FENTANYL CITRATE,	144831	134.16
01-008313	HENRY SCHEIN INC	I-66158929	01	522-0114	MEDICAL SUPPL:	112- SODIUM CHLORIDE	144879	484.96
01-008313	HENRY SCHEIN INC	I-66194723	01	522-0114	MEDICAL SUPPL:	FLEX-ALL SPLNT, MISC	144879	433.24

7/10/2019 6:47 PM

REGULAR DEPARTMENT PAYMENT REPORT

PAGE: 14

VENDOR SET: 01 City of South Padre Islan

BANK: OPER

FUND : 01 GENERAL FUND

DEPARTMENT: 522 FIRE DEPARTMENT

INVOICE DATE RANGE: 1/01/1998 THRU 99/99/9999

PAY DATE RANGE: 6/20/2019 THRU 7/12/2019

BUDGET TO USE: CB-CURRENT BUDGET

VENDOR	NAME	ITEM #	G/L ACCOUNT	NAME	DESCRIPTION	CHECK #	AMOUNT
01-008313	HENRY SCHEIN INC	I-66248672	01 522-0114	MEDICAL SUPPL:	10- SPLINT DESP 12 X 144933		15.80
01-008313	HENRY SCHEIN INC	I-66567708	01 522-0114	MEDICAL SUPPL:	IV CATHETER, ALBUTER 144933		449.89
VENDOR 01-008313 TOTALS							1,568.45
01-012133	LIFE - ASSIST, INC	I-924959	01 522-0114	MEDICAL SUPPL:	6-QUELICIN 200 MG. 144886		249.62
VENDOR 01-012133 TOTALS							249.62
01-013404	MOUNTAIN GLACIER, LLC	I-0301174528	01 522-0415	SERVICE CONTR:	BOTTLED WATER DEL. F 144887		18.00
01-013404	MOUNTAIN GLACIER, LLC	I-0301176335	01 522-0415	SERVICE CONTR:	BOTTLED WATER DEL, .F 144939		33.98
VENDOR 01-013404 TOTALS							51.98
01-013506	METRO FIRE APPARATUS S	I-132452-1	01 522-0117	SAFETY SUPPLI:	Bunker Gear 144543		10,163.00
VENDOR 01-013506 TOTALS							10,163.00
01-018509	SAM'S CLUB DIRECT	I-2539763995	01 522-0160	LAUNDRY & JAN:	JANITORIAL SUPPLIES, 144891		387.33
01-018509	SAM'S CLUB DIRECT	I-2539763995	01 522-0170	DORM AND KITC:	DORM SUPPLIES 144891		9.92
VENDOR 01-018509 TOTALS							397.25
01-019292	SEAN M. SIMON	I-62219	01 522-0150	MINOR TOOLS &:	REIMBURSE PURCHASE O 000302		6.99
VENDOR 01-019292 TOTALS							6.99
01-020016	TERMINIX	I-386874976	01 522-0415	SERVICE CONTR:	PEST CONTROL 106 W R 144895		146.00
VENDOR 01-020016 TOTALS							146.00
01-020057	TML MULTISTATE IEBP	I-070119	01 522-0081	GROUP INSURAN:	JULY 2019 MEDICAL PR 000289		14,524.99
VENDOR 01-020057 TOTALS							14,524.99
01-022253	VERATHON INC.	I-1127310	01 522-0114	MEDICAL SUPPL:	Glide Scope 144959		4,236.24
VENDOR 01-022253 TOTALS							4,236.24

7/10/2019 6:47 PM

REGULAR DEPARTMENT PAYMENT REPORT

PAGE: 15

VENDOR SET: 01 City of South Padre Island

BANK: OPER

FUND : 01 GENERAL FUND

DEPARTMENT: 522 FIRE DEPARTMENT

INVOICE DATE RANGE: 1/01/1998 THRU 99/99/9999

PAY DATE RANGE: 6/20/2019 THRU 7/12/2019

BUDGET TO USE: CB-CURRENT BUDGET

VENDOR	NAME	ITEM #	G/L ACCOUNT	NAME	DESCRIPTION	CHECK #	AMOUNT
01-023115	DAVID S. WOODS	I-19-4866-D	01 522-0401	FURNITURE & F:	Recliners	144960	1,380.00
VENDOR 01-023115 TOTALS							1,380.00
01-024001	RICHARD J. YBARRA, M.D	I-7565	01 522-0530	PROFESSIONAL :	Medical Director Fee	144962	1,000.00
VENDOR 01-024001 TOTALS							1,000.00
01-1	B & E MEDICAL SUPPLY & I-15399		01 522-0114	MEDICAL SUPPL:	B & E MEDICAL SUPPLY	144912	464.20
VENDOR 01-1 TOTALS							464.20

DEPARTMENT 522 FIRE DEPARTMENT TOTAL: 37,721.82

7/10/2019 6:47 PM

REGULAR DEPARTMENT PAYMENT REPORT

PAGE: 16

VENDOR SET: 01 City of South Padre Islan

BANK: OPER

FUND : 01 GENERAL FUND

DEPARTMENT: 532 HEALTH/CODE ENFORCEMENT

INVOICE DATE RANGE: 1/01/1998 THRU 99/99/9999

PAY DATE RANGE: 6/20/2019 THRU 7/12/2019

BUDGET TO USE: CB-CURRENT BUDGET

VENDOR	NAME	ITEM #	G/L ACCOUNT	NAME	DESCRIPTION	CHECK #	AMOUNT
01-001129	A & W OFFICE SUPPLY IN	I-635280-0	01 532-0101	OFFICE SUPPLI:	3- SP INK CARTRIDGES	144808	243.95
VENDOR 01-001129 TOTALS							243.95
01-001211	ALEX AVALOS PRINTING	I-61019	01 532-0118	PRINTING	: PRINTED 100 NOTICE T	144866	279.00
VENDOR 01-001211 TOTALS							279.00
01-008133	MIGUEL ANGEL HERNANDEZ	I-06-19	01 532-0545	LOT MOWING	: MOWING @ 110 E OLEAN	000291	50.00
01-008133	MIGUEL ANGEL HERNANDEZ	I-07-19	01 532-0545	LOT MOWING	: MOWING @ 201 W. SATU	000291	40.00
VENDOR 01-008133 TOTALS							90.00
01-015010	OFFICE DEPOT	I-326067640001	01 532-0101	OFFICE SUPPLI:	2- 3 PK HIGHLIGHTERS	144844	20.58
01-015010	OFFICE DEPOT	I-328605510001	01 532-0101	OFFICE SUPPLI:	1- HP CYAN TONER	144844	92.10
01-015010	OFFICE DEPOT	I-337285415001	01 532-0101	OFFICE SUPPLI:	1-BLK TONER, POST IT	144944	94.57
VENDOR 01-015010 TOTALS							207.25
01-020057	TML MULTISTATE IEBF	I-070119	01 532-0081	GROUP INSURAN:	JULY 2019 MEDICAL PR	000289	3,073.66
VENDOR 01-020057 TOTALS							3,073.66
DEPARTMENT 532 HEALTH/CODE ENFORCEMENT TOTAL:							3,893.86

7/10/2019 6:47 PM

REGULAR DEPARTMENT PAYMENT REPORT

PAGE: 17

VENDOR SET: 01 City of South Padre Islan

BANK: OPER

FUND : 01 GENERAL FUND

DEPARTMENT: 540 FLEET MANAGEMENT

INVOICE DATE RANGE: 1/01/1998 THRU 99/99/9999

PAY DATE RANGE: 6/20/2019 THRU 7/12/2019

BUDGET TO USE: CB-CURRENT BUDGET

VENDOR	NAME	ITEM #	G/L ACCOUNT	NAME	DESCRIPTION	CHECK #	AMOUNT
01-012091	CINTAS UNIFORM	I-4024031973	01 540-0130	WEARING APPAR:	UNIFORMS, FLEET	144834	21.67
01-012091	CINTAS UNIFORM	I-4024504692	01 540-0130	WEARING APPAR:	UNIFORMS, MATS, MOPS	144885	21.67
01-012091	CINTAS UNIFORM	I-4025057111	01 540-0130	WEARING APPAR:	UNIFORMS MATS, MOPS	144885	21.67
01-012091	CINTAS UNIFORM	I-4025425338	01 540-0130	WEARING APPAR:	UNIFORMS, FLEET	144937	21.67
VENDOR 01-012091 TOTALS							86.68
01-013339	MICHAEL MOYER	I-070319	01 540-0104-05	FUEL & LUBRIC:	REIMBURSE FOR FUEL M	144938	20.00
VENDOR 01-013339 TOTALS							20.00
01-018031	ALFREDO RAMOS	I-398	01 540-0420-02	REPAIRS & MAI:	INSPECT ENG #1 FERRA	000281	321.78
01-018031	ALFREDO RAMOS	I-399	01 540-0420-02	REPAIRS & MAI:	WORK ON ENG. #1 PRIM	000281	493.81
VENDOR 01-018031 TOTALS							815.59
01-019023	TRUCKERS EQUIPMENT INC	I-0001958.1N	01 540-0420-03	REPAIRS & MAI:	ALUMINIUM STAKE BED	144849	9,808.02
VENDOR 01-019023 TOTALS							9,808.02
01-020057	TML MULTISTATE IEBP	I-070119	01 540-0081	GROUP INSURAN:	JULY 2019 MEDICAL PR	000289	1,041.08
VENDOR 01-020057 TOTALS							1,041.08
01-021134	UNITED RENTALS (NORTH	I-154666463-019	01 540-0510	RENTAL OF EQU:	1 YEAR RENTAL-BACKHO	144907	1,775.07
VENDOR 01-021134 TOTALS							1,775.07
01-021226	US BANK VOYAGER FLEET	I-869326488926	01 540-0104-01	FUEL & LUBRIC:	FUEL PURCHASED MAY 2	144909	6,037.26
01-021226	US BANK VOYAGER FLEET	I-869326488926	01 540-0104-02	FUEL & LUBRIC:	FUEL PURCHASED MAY 2	144909	1,119.96
01-021226	US BANK VOYAGER FLEET	I-869326488926	01 540-0104-03	FUEL & LUBRIC:	FUEL PURCHASED MAY 2	144909	3,006.52
01-021226	US BANK VOYAGER FLEET	I-869326488926	01 540-0104-04	FUEL & LUBRIC:	FUEL PURCHASED MAY 2	144909	1,437.16
01-021226	US BANK VOYAGER FLEET	I-869326488926	01 540-0104-05	FUEL & LUBRIC:	FUEL PURCHASED MAY 2	144909	1,454.94
VENDOR 01-021226 TOTALS							13,055.84
DEPARTMENT 540 FLEET MANAGEMENT						TOTAL:	26,602.28

7/10/2019 6:47 PM

REGULAR DEPARTMENT PAYMENT REPORT

PAGE: 18

VENDOR SET: 01 City of South Padre Island

BANK: OPER

FUND : 01 GENERAL FUND

DEPARTMENT: 541 BUILDING MAINTENANCE

INVOICE DATE RANGE: 1/01/1998 THRU 99/99/9999

PAY DATE RANGE: 6/20/2019 THRU 7/12/2019

BUDGET TO USE: CB-CURRENT BUDGET

VENDOR	NAME	ITEM #	G/L ACCOUNT	NAME	DESCRIPTION	CHECK #	AMOUNT
01-004004	DANNY PAYTON ELECTRIC	I-21791	01 541-0410	MACHINERY & E:	CHECK & ADJUST GOVER	144924	600.00
						VENDOR 01-004004 TOTALS	600.00
01-012091	CINTAS UNIFORM	I-4024031973	01 541-0130	WEARING APPAR:	UNIFORMS, FACILITY M	144834	21.67
01-012091	CINTAS UNIFORM	I-4024031973	01 541-0160	LAUNDRY & JAN:	JANITORIAL	144834	251.70
01-012091	CINTAS UNIFORM	I-4024504692	01 541-0130	WEARING APPAR:	UNIFORMS, MATS, MOPS	144885	21.67
01-012091	CINTAS UNIFORM	I-4024504692	01 541-0160	LAUNDRY & JAN:	UNIFORMS, MATS, MOPS	144885	251.70
01-012091	CINTAS UNIFORM	I-4025057111	01 541-0130	WEARING APPAR:	UNIFORMS MATS, MOPS	144885	21.67
01-012091	CINTAS UNIFORM	I-4025057111	01 541-0160	LAUNDRY & JAN:	UNIFORMS MATS, MOPS	144885	251.70
01-012091	CINTAS UNIFORM	I-4025425338	01 541-0130	WEARING APPAR:	UNIFORMS, FACILITY M	144937	21.67
01-012091	CINTAS UNIFORM	I-4025425338	01 541-0160	LAUNDRY & JAN:	MISC. JANITORIAL SPP	144937	251.70
						VENDOR 01-012091 TOTALS	1,093.48
01-013114	MATHESON TRI-GAS INC.	I-19784286	01 541-0415	SERVICE CONTR:	MISC. ACETYLENE	144834	275.64
						VENDOR 01-013114 TOTALS	275.64
01-019494	TCR - THE BEST ALARM,	I-052966	01 541-0410	MACHINERY & E:	REPLACED SMOKE DETEC	144949	570.00
						VENDOR 01-019494 TOTALS	570.00
01-019499	SOUTHWEST TEXAS EQUIPM	I-2382730	01 541-0415	SERVICE CONTR:	ICE MACHINE RENT JUL	144893	100.00
						VENDOR 01-019499 TOTALS	100.00
01-020016	TERMINIX	I-386865212	01 541-0415	SERVICE CONTR:	PEST CONTROL 4501 PA	144854	52.00
01-020016	TERMINIX	I-386996844	01 541-0415	SERVICE CONTR:	PEST CONTROL 4601 PA	144854	234.00
						VENDOR 01-020016 TOTALS	286.00
01-020057	TML MULTISTATE IEBP	I-070238	01 541-0081	GROUP INSURAN:	JULY 2019 MEDICAL PR	000289	1,041.08
						VENDOR 01-020057 TOTALS	1,041.08
01-023160	WORTH HYDROCHEM OF COR	I-22743	01 541-0415	SERVICE CONTR:	WATER TREATMENT JUNE	000305	300.00
						VENDOR 01-023160 TOTALS	300.00

DEPARTMENT 541 BUILDING MAINTENANCE TOTAL: 4,266.20

7/10/2019 6:47 PM

REGULAR DEPARTMENT PAYMENT REPORT

PAGE: 19

VENDOR SET: 01 City of South Padre Island

BANK: OPER

FUND : 01 GENERAL FUND

DEPARTMENT: 542 INSPECTIONS DIVISION

INVOICE DATE RANGE: 1/01/1998 THRU 99/99/9999

PAY DATE RANGE: 6/20/2019 THRU 7/12/2019

BUDGET TO USE: CB-CURRENT BUDGET

VENDOR	NAME	ITEM #	G/L ACCOUNT	NAME	DESCRIPTION	CHECK #	AMOUNT
01-001129	A & W OFFICE SUPPLY IN	C-C635122-0	01 542-0101	OFFICE SUPPLI:	DATE STAMP RETURNED	144754	50.86-
01-001129	A & W OFFICE SUPPLY IN	I-635122-0	01 542-0101	OFFICE SUPPLI:	FILE FLDRS, DATER, P	144754	162.25
01-001129	A & W OFFICE SUPPLY IN	I-635201-0	01 542-0150	MINOR TOOLS &:	1-VERSDATER STAMP	144754	65.90
VENDOR 01-001129 TOTALS							179.29
01-013367	ALEXANDER M. MOORE	I-62419	01 542-0550	TRAVEL EXPENS:	PER DIEM & PARKING	000287	118.00
VENDOR 01-013367 TOTALS							118.00
01-020057	TML MULTISTATE IEBP	I-670119	01 542-0081	GROUP INSURAN:	JULY 2019 MEDICAL PR	000289	1,571.62
VENDOR 01-020057 TOTALS							1,571.62
DEPARTMENT 542 INSPECTIONS DIVISION TOTAL:							1,866.91

7/10/2019 6:47 PM

REGULAR DEPARTMENT PAYMENT REPORT

PAGE: 20

VENDOR SET: 01 City of South Padre Islan

BANK: OPER

FUND : 01 GENERAL FUND

DEPARTMENT: 543 PUBLIC WORKS DEPARTMENT

INVOICE DATE RANGE: 1/01/1998 THRU 99/99/9999

PAY DATE RANGE: 6/20/2019 THRU 7/12/2019

BUDGET TO USE: CB-CURRENT BUDGET

VENDOR	NAME	ITEM #	G/L	ACCOUNT	NAME	DESCRIPTION	CHECK #	AMOUNT
01-001985	JIM CORBETT	DBA BACK I-90581	01	543-0412	LANDSCAPE	: REPAIR AND RETEST BA	144757	183.70
VENDOR 01-001985 TOTALS								183.70
01-003704	CAMERON COUNTY	I-62019	01	543-0432	CAUSEWAY LIGH:	CAUSEWAY LTNG MAY 6	144817	128.63
01-003704	CAMERON COUNTY	I-7319	01	543-0432	CAUSEWAY LIGH:	CAUSEWAY LTNG MAY 16	144922	131.09
VENDOR 01-003704 TOTALS								259.72
01-006184	FREEEDOM	ROC INDUSTRI I-2588	01	543-0416	STREETS & RIG:	25 GALLONS LOOP SEAL	144766	745.10
VENDOR 01-006184 TOTALS								745.10
01-007399	GRAINGER	I-9200970516	01	543-0112	SIGNS	: TAPE FOR DELINEATORS	144769	375.18
VENDOR 01-007399 TOTALS								375.18
01-012091	CINTAS UNIFORM	I-4024031973	01	543-0130	WEARING APPAR:	UNIFORMS, PUBLIC WRK	144834	190.35
01-012091	CINTAS UNIFORM	I-4024504692	01	543-0130	WEARING APPAR:	UNIFORMS, MATS, MOPS	144885	190.35
01-012091	CINTAS UNIFORM	I-4025057111	01	543-0130	WEARING APPAR:	UNIFORMS MATS, MOPS	144885	190.35
01-012091	CINTAS UNIFORM	I-4025425338	01	543-0130	WEARING APPAR:	UNIFORMS, PWRKS	144937	190.35
VENDOR 01-012091 TOTALS								761.40
01-014039	NSTS LLC	I-3784	01	543-0112	SIGNS	: GALVANIZED ROUND POS	144841	1,997.26
VENDOR 01-014039 TOTALS								1,997.26
01-020057	TML MULTISTATE	IEBP I-070119	01	543-0081	GROUP INSURAN:	JULY 2019 MEDICAL PR	000289	10,342.72
VENDOR 01-020057 TOTALS								10,342.72
01-1	RMA TOLL PROCESSING	I-100003592386	01	543-0550	TRAVEL EXPENS:	RMA TOLL PROCESSING:	144963	8.61
01-1	TXTAG	I-196115055355	01	543-0550	TRAVEL EXPENS:	TXTAG: TOLL FEE 5/15	144913	8.76
01-1	JASON YETTER	I-62419	01	543-0413	PADRE BLVD ME:	JASON YETTER: REIMBU	144862	398.59
VENDOR 01-1 TOTALS								415.96

DEPARTMENT 543 PUBLIC WORKS DEPARTMENT TOTAL: 15,081.04

VENDOR SET: 01 City of South Padre Islan

BANK: OPER

FUND : 01 GENERAL FUND

DEPARTMENT: 570 GENERAL SERVICES

INVOICE DATE RANGE: 1/01/1998 THRU 99/99/9999

PAY DATE RANGE: 6/20/2019 THRU 7/12/2019

BUDGET TO USE: CB-CURRENT BUDGET

VENDOR	NAME	ITEM #	G/L ACCOUNT	NAME	DESCRIPTION	CHECK #	AMOUNT
01-003430	CNA SURETY	I-70219	01 570-9060	OFFICIALS/LAW: BOND #68383267	TX P 144869		371.00
VENDOR 01-003430 TOTALS							371.00
01-004133	DENTON NAVARRO ROCHA B	I-025005	01 570-9030	LEGAL SERVICE: CONTRACT/DOCUMENT RE	144925		11.00
01-004133	DENTON NAVARRO ROCHA B	I-025008	01 570-9030	LEGAL SERVICE: PROF SERV:MAY LITIGA	144925		370.00
01-004133	DENTON NAVARRO ROCHA B	I-24910	01 570-9030	LEGAL SERVICE: SPI SPEC. COUNSEL :	144761		2,055.00
01-004133	DENTON NAVARRO ROCHA B	I-24911	01 570-9030	LEGAL SERVICE: PROF.SERV CONTRACT/D	144762		611.00
01-004133	DENTON NAVARRO ROCHA B	I-25004	01 570-9030	LEGAL SERVICE: PROF LEGAL SERV. MAY	144925		2,961.00
01-004133	DENTON NAVARRO ROCHA B	I-25007	01 570-9030	LEGAL SERVICE: SPI HR MATTERS: MAY	144925		92.50
01-004133	DENTON NAVARRO ROCHA B	I-25010	01 570-9030	LEGAL SERVICE: PROF SER. MAY LNG P	144925		630.00
01-004133	DENTON NAVARRO ROCHA B	I-25011	01 570-9030	LEGAL SERVICE: PROF. SER. MAY 2019	144925		74.00
01-004133	DENTON NAVARRO ROCHA B	I-25012	01 570-9030	LEGAL SERVICE: PROF SERV. MAY 2019,	144925		2,850.00
01-004133	DENTON NAVARRO ROCHA B	I-25013	01 570-9030	LEGAL SERVICE: PROF SERV. MAY 2019	144925		271.30
01-004133	DENTON NAVARRO ROCHA B	I-25014	01 570-9030	LEGAL SERVICE: PROF. SERV.TPIA REQU	144925		147.50
VENDOR 01-004133 TOTALS							10,073.30
01-004446	ESTRADA HINOJOSA & CO	I-3753	01 570-9025	INVESTMENT AD: CONTINUING DISCLOSUR	144821		2,000.00
VENDOR 01-004446 TOTALS							2,000.00
01-006034	FED EX	I-6-589-55269	01 570-0108	POSTAGE : MISC. SHIPPING CHARG	144823		57.77
VENDOR 01-006034 TOTALS							57.77
01-007115	GEXA ENERGY, LP	I-28079672-4	01 570-0580	ELECTRICITY : ELECTRIC BILL DATED	144876		13,899.46
01-007115	GEXA ENERGY, LP	I-28079674-4	01 570-0580	ELECTRICITY : 4617 GULF BLVD	144931		15.98
VENDOR 01-007115 TOTALS							13,915.44
01-013404	MOUNTAIN GLACIER, LLC	I-0301149191	01 570-0581	WATER, SEWER, : BOTTLED WATER DEL CI	144939		67.50
01-013404	MOUNTAIN GLACIER, LLC	I-0301153186	01 570-0581	WATER, SEWER, : BOTTLED WATER DEL. C	144939		60.00
01-013404	MOUNTAIN GLACIER, LLC	I-0301168869	01 570-0581	WATER, SEWER, : BOTTLED WATER DEL. C	144939		60.00
01-013404	MOUNTAIN GLACIER, LLC	I-0301172696	01 570-0581	WATER, SEWER, : BOTTLED WATER PUB WR	144838		54.00
01-013404	MOUNTAIN GLACIER, LLC	I-0301172705	01 570-0581	WATER, SEWER, : BOTTLED WATER DEL. P	144776		58.50
01-013404	MOUNTAIN GLACIER, LLC	I-0301174518	01 570-0581	WATER, SEWER, : BOTTLED WATER DEL. C	144838		99.00
01-013404	MOUNTAIN GLACIER, LLC	I-0301176329	01 570-0581	WATER, SEWER, : BOTTLED WATER DEL. P	144939		57.00
01-013404	MOUNTAIN GLACIER, LLC	I-0301176331	01 570-0581	WATER, SEWER, : COOLER RENTAL SPI C	144887		2.00
01-013404	MOUNTAIN GLACIER, LLC	I-0301176333	01 570-0581	WATER, SEWER, : BOTTLED WATER DEL.	144887		51.00
01-013404	MOUNTAIN GLACIER, LLC	I-0301176343	01 570-0581	WATER, SEWER, : BOTTLED WATER DEL P	144887		63.00
VENDOR 01-013404 TOTALS							572.00

VENDOR SET: 01 City of South Padre Islan

BANK: OPER

FUND : 01 GENERAL FUND

DEPARTMENT: 570 GENERAL SERVICES

INVOICE DATE RANGE: 1/01/1998 THRU 99/99/9999

PAY DATE RANGE: 6/20/2019 THRU 7/12/2019

BUDGET TO USE: CB-CURRENT BUDGET

VENDOR	NAME	ITEM #	G/L ACCOUNT	NAME	DESCRIPTION	CHECK #	AMOUNT
01-018154	REPUBLIC SERVICES #863	I-0863001669325	01 570-0581	WATER, SEWER, :	108 W. RETAMA, ON CA	144847	1,734.18
01-018154	REPUBLIC SERVICES #863	I-0863001677421	01 570-0581	WATER, SEWER, :	SERVICE @ 4501 PADRE	144945	363.36
						VENDOR 01-018154 TOTALS	2,097.54
01-020047	TML - INTERGOVERNMENTA	I-060119	01 570-9061	ERRORS & OMIS:	APRIL 2019 DEDUCTIBL	144780	2,500.00
01-020047	TML - INTERGOVERNMENTA	I-060119	01 570-9051	GENERAL LIABI:	APRIL 2019 DEDUCTIBL	144780	1,226.79
01-020047	TML - INTERGOVERNMENTA	I-70119	01 570-9061	ERRORS & OMIS:	MAY 2019 DEDUCTIBLES	144896	167.00
						VENDOR 01-020047 TOTALS	3,893.79
01-022249	VICTOR O. SCHINNERER &	I-S1752781	01 570-9052	WINDSTORM INS:	WINDSTORM POL 7/02/1	144804	21,384.19
						VENDOR 01-022249 TOTALS	21,384.19
01-023900	XEROX CORPORATION	I-097091970	01 570-0510	RENTAL OF EQU:	ADM. COPIER/PRINTER	144788	998.91
01-023900	XEROX CORPORATION	I-097091973	01 570-0510	RENTAL OF EQU:	COPIER/PRINTER LEASE	144788	505.71
01-023900	XEROX CORPORATION	I-097091975	01 570-0510	RENTAL OF EQU:	COPIER LEASE PUB. WR	144788	980.61
01-023900	XEROX CORPORATION	I-097091976	01 570-0510	RENTAL OF EQU:	COPIER/PRINTER PD -C	144788	665.12
01-023900	XEROX CORPORATION	I-097239216	01 570-0510	RENTAL OF EQU:	COPIER LEASE MAY JAI	144860	196.47
01-023900	XEROX CORPORATION	I-097367603	01 570-0510	RENTAL OF EQU:	ADM. COPIER/PRINTER	144961	1,017.30
01-023900	XEROX CORPORATION	I-097367604	01 570-0510	RENTAL OF EQU:	INTRGRATED CONTRLR,	144961	108.48
01-023900	XEROX CORPORATION	I-097367606	01 570-0510	RENTAL OF EQU:	COPIER/PRINTER LEASE	144961	477.60
01-023900	XEROX CORPORATION	I-097367607	01 570-0510	RENTAL OF EQU:	COPIER LEASE FIRE DE	144961	298.64
01-023900	XEROX CORPORATION	I-097367608	01 570-0510	RENTAL OF EQU:	COPIER LEASE PUB. WR	144961	887.25
01-023900	XEROX CORPORATION	I-097367609	01 570-0510	RENTAL OF EQU:	COPIER/PRINTER PD -C	144961	725.02
01-023900	XEROX CORPORATION	I-097367613	01 570-0510	RENTAL OF EQU:	COPIER LEASE JUNE 20	144961	75.00
						VENDOR 01-023900 TOTALS	6,936.11
DEPARTMENT 570 GENERAL SERVICES						TOTAL:	61,361.14

VENDOR SET: 01 City of South Padre Islan

BANK: OPER

FUND : 01 GENERAL FUND

DEPARTMENT: 572 SPECIAL PROJECTS

INVOICE DATE RANGE: 1/01/1998 THRU 99/99/9999

PAY DATE RANGE: 6/20/2019 THRU 7/12/2019

BUDGET TO USE: CB-CURRENT BUDGET

VENDOR	NAME	ITEM #	G/L ACCOUNT	NAME	DESCRIPTION	CHECK #	AMOUNT
01-018018	RALPH ANDERSEN & ASSC.	I-INV-02095	01 572-0530	PROFESSIONAL :	SERVICES RENDERED PR 144803		8,850.00
						VENDOR 01-018018 TOTALS	8,850.00
						DEPARTMENT 572 SPECIAL PROJECTS TOTAL:	8,850.00
						VENDOR SET 01 GENERAL FUND TOTAL:	394,036.83

VENDOR SET: 01 City of South Padre Islan

BANK: OPER

FUND : 02 HOTEL/MOTEL TAX FUND

DEPARTMENT: N/A NON-DEPARTMENTAL

INVOICE DATE RANGE: 1/01/1998 THRU 99/99/9999

PAY DATE RANGE: 6/20/2019 THRU 7/12/2019

BUDGET TO USE: CB-CURRENT BUDGET

VENDOR	NAME	ITEM #	G/L ACCOUNT	NAME	DESCRIPTION	CHECK #	AMOUNT
01-022249	VICTOR O. SCHINNERER & I-	S1752781	02 1400	PREPAID EXPEN:	WINDSTORM POL 7/02/1	144804	5,934.75
						VENDOR 01-022249 TOTALS	5,934.75
				DEPARTMENT	NON-DEPARTMENTAL	TOTAL:	5,934.75

VENDOR SET: 01 City of South Padre Island

BANK: OPER

FUND : 02 HOTEL/MOTEL TAX FUND

DEPARTMENT: 590 VISITORS BUREAU

INVOICE DATE RANGE: 1/01/1998 THRU 99/99/9999

PAY DATE RANGE: 6/20/2019 THRU 7/12/2019

BUDGET TO USE: CB-CURRENT BUDGET

VENDOR	NAME	ITEM #	G/L ACCOUNT	NAME	DESCRIPTION	CHECK #	AMOUNT
01-004089	DEPT OF INFO RESOURCES	I-19050601N	02 590-0501	COMMUNICATION:	TEX-ANNG CHRGS, MAY	000278	5.14
				VENDOR 01-004089	TOTALS		5.14
01-007115	GEXA ENERGY, LP	I-28079672-4	02 590-0580	ELECTRICITY :	ELECTRIC BILL DATED	144876	531.76
				VENDOR 01-007115	TOTALS		531.76
01-013050	MAIL FINANCE	I-N7768432	02 590-0415	SERVICE CONTR:	POSTAGE METER LEASE:	144775	1,514.44
				VENDOR 01-013050	TOTALS		1,514.44
01-013404	MOUNTAIN GLACIER, LLC	I-5301174519	02 590-0101	OFFICE SUPPLI:	BOTTLED WATER DEL. V	144838	8.50
				VENDOR 01-013404	TOTALS		8.50
01-014237	DONNELLY HOLDINGS, LTD	I-830273	02 590-0415	SERVICE CONTR:	FILTER HVAC	144842	22.50
				VENDOR 01-014237	TOTALS		22.50
01-018154	REPUBLIC SERVICES #863	I-0863001678768	02 590-0581	WATER,SEWER &:	610 PADRE BLVD JULY	144890	105.94
				VENDOR 01-018154	TOTALS		105.94
01-020057	TML MULTISTATE IEBP	I-070119	02 590-0081	GROUP INSURAN:	JULY 2019 MEDICAL PR	000289	1,561.62
				VENDOR 01-020057	TOTALS		1,561.62
01-020185	TIME WARNER CABLE	I-0029235061219	02 590-0415	SERVICE CONTR:	600 PADRE RR2 ACCT,	144855	415.31
				VENDOR 01-020185	TOTALS		415.31
01-020355	TK LAWN CARE	I-1860	02 590-0412	LANDSCAPE :	LANDSCAPE VC	144901	220.00
				VENDOR 01-020355	TOTALS		220.00
01-020602	TOUCAN GRAPHICS	I-27158	02 590-0101	OFFICE SUPPLI:	1 NAME BADGE, LILI R	144857	23.01
				VENDOR 01-020602	TOTALS		23.01

VENDOR SET: 01 City of South Padre Islan

BANK: OPER

FUND : 02 HOTEL/MOTEL TAX FUND

DEPARTMENT: 590 VISITORS BUREAU

INVOICE DATE RANGE: 1/01/1998 THRU 99/99/9999

PAY DATE RANGE: 6/20/2019 THRU 7/12/2019

BUDGET TO USE: CB-CURRENT BUDGET

VENDOR	NAME	ITEM #	G/L ACCOUNT	NAME	DESCRIPTION	CHECK #	AMOUNT
01-021095	UNITED PARCEL SERVICE	I-0000648239269-1	02 590-0108	POSTAGE	WEEKLY SERV CHARGE	144956	29.00
VENDOR 01-021095 TOTALS							29.00
01-021102	UNIFIRST HOLDINGS, INC	I-8132862212	02 590-0415	SERVICE CONTR:	MATS, MOPS, ETC	000284	74.50
VENDOR 01-021102 TOTALS							74.50
01-021226	US BANK VOYAGER FLEET	I-869326488926	02 590-0104	FUELS & LUBRI:	FUEL PURCHASED MAY 2	144909	27.54
VENDOR 01-021226 TOTALS							27.54
01-022249	VICTOR O. SCHINNERER &	I-SI752781	02 590-0520	INSURANCE	WINDSTORM POL 7/02/1	144804	1,978.25
VENDOR 01-022249 TOTALS							1,978.25
01-022254	I. T. VERDIN COMPANY	I-cinv3263	02 590-1001	BUILDINGS & S:	BIKE RACKS	144910	2,890.00
VENDOR 01-022254 TOTALS							2,890.00
01-023900	XEROX CORPORATION	I-097367610	02 590-0415	SERVICE CONTR:	VISITOR CENTER XEROX	144961	250.35
VENDOR 01-023900 TOTALS							250.35
DEPARTMENT 590 VISITORS BUREAU						TOTAL:	9,657.86

VENDOR SET: 01 City of South Padre Islan

BANK: OPER

FUND : 02 HOTEL/MOTEL TAX FUND

DEPARTMENT: 592 SALES & ADMINISTRATION

INVOICE DATE RANGE: 1/01/1998 THRU 99/99/9999

PAY DATE RANGE: 6/20/2019 THRU 7/12/2019

BUDGET TO USE: CB-CURRENT BUDGET

VENDOR	NAME	ITEM #	G/L	ACCOUNT	NAME	DESCRIPTION	CHECK #	AMOUNT
01-002882	BLIZZARD INTERNET MARK	I-2019-3759#	02	592-0415	SERVICE CONTR:	BOOKING ENGINE FOR W 144918		600.00
						VENDOR 01-002882 TOTALS		600.00
01-003444	CITIBANK	I-60319	02	592-0550	TRAVEL EXPENS:	CREDIT CVB 144805		101.97-
						VENDOR 01-003444 TOTALS		101.97-
01-004089	DEPT OF INFO RESOURCES	I-19050601N	02	592-0501	COMMUNICATION:	TEX-ANNG CHRGS, MAY 000278		74.17
						VENDOR 01-004089 TOTALS		74.17
01-004133	DENTON NAVARRO ROCHA B	I-025005	02	592-0530	PROFESSIONAL :	CONTRACT/DOCUMENT RE 144925		153.50
01-004133	DENTON NAVARRO ROCHA B	I-24910	02	592-0530	PROFESSIONAL :	SPI SPEC. CCUNSEL : 144761		156.50
01-004133	DENTON NAVARRO ROCHA B	I-24911	02	592-0530	PROFESSIONAL :	PROF.SERV CONTRACT/D 144762		206.00
01-004133	DENTON NAVARRO ROCHA B	I-25009	02	592-0530	PROFESSIONAL :	PROF SERV: MAY 2019 144925		376.50
						VENDOR 01-004133 TOTALS		892.50
01-006034	FED EX	I-6-588-85296	02	592-0108	POSTAGE :	MISC SHIPPING CHARGE 144823		476.75
						VENDOR 01-006034 TOTALS		476.75
01-006170	MICHAEL FLORES	I-61819	02	592-0550	TRAVEL EXPENS:	PRE DIEM: FT WORTH T 000286		156.00
						VENDOR 01-006170 TOTALS		156.00
01-008160	HELMS BRISCOE PERFORMA	I-HBP6891	02	592-0538	CONVENTION SE:	2019 HELMSBRISCOE AG 144770		2,900.00
						VENDOR 01-008160 TOTALS		2,900.00
01-011014	JUAN JOSE MORA	I-0613	02	592-0130	WEARING APPAR:	5-SPI LOGOS EMBROIDE 144934		35.00
						VENDOR 01-011014 TOTALS		35.00
01-013500	MEETING PROFESSIONALS	I-665162	02	592-0538	CONVENTION SE:	PYM AUSTIN DALLAS 144942		5,000.00
						VENDOR 01-013500 TOTALS		5,000.00

VENDOR SET: 01 City of South Padre Island

BANK: OPER

FUND : 02 HOTEL/MOTEL TAX FUND

DEPARTMENT: 592 SALES & ADMINISTRATION

INVOICE DATE RANGE: 1/01/1998 THRU 99/99/9999

PAY DATE RANGE: 6/20/2019 THRU 7/12/2019

BUDGET TO USE: CB-CURRENT BUDGET

VENDOR	NAME	ITEM #	G/L ACCOUNT	NAME	DESCRIPTION	CHECK #	AMOUNT
01-014989	OMNI FORT WORTH PARTNE	I-71521	02 592-0538	CONVENTION SE:	TCMA BFAS T SPONSORSH	144843	14,322.00
					VENDOR 01-014989 TOTALS		14,322.00
01-015011	OFFICE OF THE GOVERNOR	I-6619	02 592-0553	TRADE SHOW FE:	GUADALAJARA, MX ARLA	144777	1,000.00
					VENDOR 01-015011 TOTALS		1,000.00
01-018200	REGAL PLASTIC SUPPLY C	I-0003660	02 592-0538	CONVENTION SE:	WHITE BOARDS	144946	570.00
					VENDOR 01-018200 TOTALS		570.00
01-018509	SAM'S CLUB DIRECT	I-4486	02 592-0102	LOCAL MEETING:	2-FRENCH MACARONS- M	144891	31.96
					VENDOR 01-018509 TOTALS		31.96
01-019031	SCHLITTERBAHN BEACH WA	I-78572	02 592-0102	LOCAL MEETING:	BRKFST-1/21/19 CVA B	144778	229.75
01-019031	SCHLITTERBAHN BEACH WA	I-78574	02 592-0102	LOCAL MEETING:	LUNCH FOR CVA BRD RE	144778	344.50
					VENDOR 01-019031 TOTALS		574.25
01-020057	TML MULTISTATE IEBP	I-070119	02 592-0081	GROUP INSURAN:	JULY 2019 MEDICAL PR	000289	5,775.94
					VENDOR 01-020057 TOTALS		5,775.94
01-020086	TEXAS SOCIETY OF ASSC.	I-89,378	02 592-0538	CONVENTION SE:	NEW IDEA CONF	144953	5,500.00
					VENDOR 01-020086 TOTALS		5,500.00
01-020104	SCOTT MCGEHEE	I-267-19	02 592-0108	POSTAGE	: VISITOR FULLFILLMENT	144954	668.08
01-020104	SCOTT MCGEHEE	I-268	02 592-0108	POSTAGE	: VISITOR FULLFILLMENT	144954	277.96
					VENDOR 01-020104 TOTALS		946.04
01-020185	TIME WARNER CABLE	I-0029318060619	02 592-0415	SERVICE CNTR:	7355 PADRE BLVD WIFI	144897	3,205.94
					VENDOR 01-020185 TOTALS		3,205.94

VENDOR SET: 01 City of South Padre Island

BANK: OPER

FUND : 02 HOTEL/MOTEL TAX FUND

DEPARTMENT: 592 SALES & ADMINISTRATION

INVOICE DATE RANGE: 1/01/1998 THRU 99/99/9999

PAY DATE RANGE: 6/20/2019 THRU 7/12/2019

BUDGET TO USE: CB-CURRENT BUDGET

VENDOR	NAME	ITEM #	G/L ACCOUNT	NAME	DESCRIPTION	CHECK #	AMOUNT
01-020602	TOUCAN GRAPHICS	I-26848	02 592-0538	CONVENTION SE:	REORDER PENS	144955	2,024.14
01-020602	TOUCAN GRAPHICS	I-27050	02 592-0101	OFFICE SUPPLI:	250 BUS. CARDS. APRI	144781	29.00
01-020602	TOUCAN GRAPHICS	I-27065	02 592-0538	CONVENTION SE:	250 GLOSS FLYERS PRI	144781	185.00
01-020602	TOUCAN GRAPHICS	I-27066	02 592-0538	CONVENTION SE:	PRINTED 400 FLYERS S	144781	210.00
01-020602	TOUCAN GRAPHICS	I-27136	02 592-0230	STOCK - PROMO:	2.00 HISTORICAL BRDC	144857	492.30
01-020602	TOUCAN GRAPHICS	I-27181	02 592-0538	CONVENTION SE:	PRINTED 300 FLYERS	144857	200.00
01-020602	TOUCAN GRAPHICS	I-27182	02 592-0538	CONVENTION SE:	PRINTED 5M MAPS, 4/4	144902	399.00
01-020602	TOUCAN GRAPHICS	I-27187	02 592-0230	STOCK - PROMO:	FLOATER KEY CHAINS	144902	1,303.93
01-020602	TOUCAN GRAPHICS	I-27192	02 592-0538	CONVENTION SE:	PRINTIUNG OF 5M POST	144902	250.00
01-020602	TOUCAN GRAPHICS	I-27210	02 592-0538	CONVENTION SE:	PRINTED 5M 3 X 10 BO	144902	290.00
VENDOR 01-020602 TOTALS							5,383.37
01-020896	JASON JAMES BETTINGER	I-4086	02 592-0150	MINOR TOOLS &:	CANOPY FOR SP EVENTS	144904	2,997.00
VENDOR 01-020896 TOTALS							2,997.00
01-021093	EDWARD L. CAUM	I-053119	02 592-0550	TRAVEL EXPENS:	PER DIEM: SAN ANTONI	000307	120.00
VENDOR 01-021093 TOTALS							120.00
01-021095	UNITED PARCEL SERVICE	I-0000648239239-1	02 592-0108	POSTAGE	: WEEKLY SERVICE CHARG	144783	29.00
01-021095	UNITED PARCEL SERVICE	I-0000648239249-1	02 592-0108	POSTAGE	: WEEKLY SERV. CHARGE	144859	29.00
01-021095	UNITED PARCEL SERVICE	I-0000648239259	02 592-0108	POSTAGE	: WEEKLY SERVICE CHARG	144906	29.00
VENDOR 01-021095 TOTALS							87.00
01-021149	MAGDALENA B. VASQUEZ	I-56486	02 592-0101	OFFICE SUPPLI:	2- TABLECLOTHS CLEA	144908	28.00
VENDOR 01-021149 TOTALS							28.00
01-021226	US BANK VOYAGER FLEET	I-869326488926	02 592-0104	FUELS & LUBRI:	FUEL PURCHASED MAY 2	144909	102.96
VENDOR 01-021226 TOTALS							102.96
01-023087	JAMIE WELLS	I-051319	02 592-0550	TRAVEL EXPENS:	PER DIEM: JUNE 24-28	144787	168.00
VENDOR 01-023087 TOTALS							168.00

VENDOR SET: 01 City of South Padre Island

BANK: OPER

FUND : 02 HOTEL/MOTEL TAX FUND

DEPARTMENT: 592 SALES & ADMINISTRATION

INVOICE DATE RANGE: 1/01/1998 THRU 99/99/9999

PAY DATE RANGE: 6/20/2019 THRU 7/12/2019

BUDGET TO USE: CB-CURRENT BUDGET

VENDOR	NAME	ITEM #	G/L ACCOUNT	NAME	DESCRIPTION	CHECK #	AMOUNT
01-023143	ALISHA N WORKMAN	I-060619	02 592-0550		TRAVEL EXPENS: PER DIEM & MILEAGE,	000276	470.64
VENDOR 01-023143 TOTALS							470.64
01-023900	XEROX CORPORATION	I-097367602	02 592-0415		SERVICE CONTR: XEROX CVB	144961	1,138.91
01-023900	XEROX CORPORATION	I-0979091969	02 592-0415		SERVICE CONTR: XEROX CVB	144788	1,302.87
VENDOR 01-023900 TOTALS							2,441.78
01-1	LAW OFFICE OF CINDY GA	I-061819	02 592-0530		PROFESSIONAL : MARY A. GUILLEN, SET	144800	1,604.00
01-1	JOSEPH WEINER	I-62519	02 592-0535		FAMILIARIZATI: JOSEPH WEINER:PER DI	144864	600.00
VENDOR 01-1 TOTALS							2,204.00
DEPARTMENT 592 SALES & ADMINISTRATION TOTAL:							55,961.33

VENDOR SET: 01 City of South Padre Island

BANK: OPER

FUND : 02 HOTEL/MOTEL TAX FUND

DEPARTMENT: 593 EVENTS MARKETING

INVOICE DATE RANGE: 1/01/1998 THRU 99/99/9999

PAY DATE RANGE: 6/20/2019 THRU 7/12/2019

BUDGET TO USE: CB-CURRENT BUDGET

VENDOR	NAME	ITEM #	G/L ACCOUNT	NAME	DESCRIPTION	CHECK #	AMOUNT
01-007145	GLOBALGROOVE PRODUCTIO	I-62119	02 593-8099	MISC. SPONSOR:	SPLASH 2018	144828	6,250.00
					VENDOR 01-007145 TOTALS		6,250.00
01-008139	ALAN PATRICK MALONE	I-20190271	02 593-8099	MISC. SPONSOR:	RED FISH ELITE 2019	000292	10,000.00
					VENDOR 01-008139 TOTALS		10,000.00
01-009640	JAILBREAK RACING EVENT	I-1184	02 593-8099	MISC. SPONSOR:	JAILBREAK MAY 2019	000280	7,500.00
					VENDOR 01-009640 TOTALS		7,500.00
01-011096	KNIGHTS OF COLUMBUS	I-CVB2019TOUR1	02 593-8099	MISC. SPONSOR:	FISHING TOURNAMENT	144833	1,250.00
					VENDOR 01-011096 TOTALS		1,250.00
01-018287	RYAN HAILEY ENTERPRISE	I-SPI061119	02 593-8099	MISC. SPONSOR:	SANDCRAB RUN 2018	144846	1,875.00
					VENDOR 01-018287 TOTALS		1,875.00
01-018995	SANDCASTLE ISLAND, INC	I-SCT0419	02 593-8099	MISC. SPONSOR:	SANDCASTLE TRAIL MAI	000272	1,000.00
01-018995	SANDCASTLE ISLAND, INC	I-SCT0519	02 593-8099	MISC. SPONSOR:	SANDCASTLE TRAIL MAI	000282	1,725.00
					VENDOR 01-018995 TOTALS		2,725.00
01-019172	SHALLOW SPORT OF TX, I	I-52894	02 593-8099	MISC. SPONSOR:	SHALLOW SPORT FISHIN	144850	5,000.00
					VENDOR 01-019172 TOTALS		5,000.00
01-020057	TML MULTISTATE IEBP	I-070119	02 593-0081	GROUP INSURAN:	JULY 2019 MEDICAL PR	000289	530.54
					VENDOR 01-020057 TOTALS		530.54
01-020602	TOUCAN GRAPHICS	I-26689	02 593-8060	ENTRANCE SIGN:	1- 15 X 3 MESH BANNE	144781	210.00
01-020602	TOUCAN GRAPHICS	I-27056	02 593-8060	ENTRANCE SIGN:	ART SERV. :JP MEDIAN	144781	230.00
01-020602	TOUCAN GRAPHICS	I-27078	02 593-8060	ENTRANCE SIGN:	ART SERV, 2- MESH BA	144781	460.00
01-020602	TOUCAN GRAPHICS	I-27111	02 593-8060	ENTRANCE SIGN:	ART SERBV, BANNERS,	144781	465.00
01-020602	TOUCAN GRAPHICS	I-27164	02 593-8099	MISC. SPONSOR:	ALUMINUM SIGNS COMBA	144857	1,487.50

VENDOR SET: 01 City of South Padre Islan

BANK: OPER

FUND : 02 HOTEL/MOTEL TAX FUND

DEPARTMENT: 593 EVENTS MARKETING

INVOICE DATE RANGE: 1/01/1998 THRU 99/99/9999

PAY DATE RANGE: 6/20/2019 THRU 7/12/2019

BUDGET TO USE: CB-CURRENT BUDGET

VENDOR	NAME	ITEM #	G/L ACCOUNT	NAME	DESCRIPTION	CHECK #	AMOUNT
01-020602	TOUCAN GRAPHICS	I-27178	02 593-8060	ENTRANCE SIGN: ART SERV: DIGITAL BA		144902	275.00
						VENDOR 01-020602 TOTALS	3,127.50
01-021200	URBAN SCIENCE INITIATI	I-062719	02 593-8099	MISC. SPONSOR: NWC 2019 CONF		144957	3,750.00
						VENDOR 01-021200 TOTALS	3,750.00
01-021229	UWP, LLC	I-61215-1	02 593-8099	MISC. SPONSOR: PRO WATERCROSS EVENT		000285	8,750.00
						VENDOR 01-021229 TOTALS	8,750.00
						DEPARTMENT 593 EVENTS MARKETING TOTAL:	50,758.04

VENDOR SET: 01 City of South Padre Islan

BANK: OPER

FUND : 02 HOTEL/MOTEL TAX FUND

DEPARTMENT: 594 MARKETING

INVOICE DATE RANGE: 1/01/1998 THRU 99/99/9999

PAY DATE RANGE: 6/20/2019 THRU 7/12/2019

BUDGET TO USE: CB-CURRENT BUDGET

VENDOR	NAME	ITEM #	G/L ACCOUNT	NAME	DESCRIPTION	CHECK #	AMOUNT
01-009088	INK PUBLISHING CORPORA	I-052715	02 594-0531	MEDIA PLACEME:	UNITED AIRLINES INFL	144881	19,800.00
01-009088	INK PUBLISHING CORPORA	I-052733	02 594-0531	MEDIA PLACEME:	UNITED AIRLINES INFL	144881	11,900.00
						VENDOR 01-009088 TOTALS	31,700.00
01-012090	LAMAR TEXAS LIMITED PA	I-110333837	02 594-0531	MEDIA PLACEME:	OUTDOOR BILLBOARDS R	144773	3,750.00
01-012090	LAMAR TEXAS LIMITED PA	I-110365314	02 594-0531	MEDIA PLACEME:	OUTDOOR BILLBOARDS R	144884	3,750.00
01-012090	LAMAR TEXAS LIMITED PA	I-110365314	02 594-0531	MEDIA PLACEME:	OUTDOOR BILLBOARDS R	144884	4,050.00
01-012090	LAMAR TEXAS LIMITED PA	I-110410635	02 594-0531	MEDIA PLACEME:	OUTDOOR BILLBOARDS R	144936	4,300.00
						VENDOR 01-012090 TOTALS	15,850.00
01-1	ELSEVIER	I-J1057252	02 594-0533	MARKETING	: ELSEVIER: 1- ANNALS	144863	273.00
						VENDOR 01-1 TOTALS	273.00
						DEPARTMENT 594 MARKETING TOTAL:	47,823.00
						VENDOR SET 02 HOTEL/MOTEL TAX FUND TOTAL:	170,134.98

VENDOR SET: 01 City of South Padre Islan

BANK: OPER

FUND : 03 VENUE PROJECT FUND

DEPARTMENT: 597 VENUE PROJECT

INVOICE DATE RANGE: 1/01/1998 THRU 99/99/9999

PAY DATE RANGE: 6/20/2019 THRU 7/12/2019

BUDGET TO USE: CB-CURRENT BUDGET

VENDOR	NAME	ITEM #	G/L ACCOUNT	NAME	DESCRIPTION	CHECK #	AMOUNT
01-004133	DENTON NAVARRO ROCHA B	I-24911	03 597-0530	PROFESSIONAL :	PROF.SERV CONTRACT/D	144762	190.50
VENDOR 01-004133 TOTALS							190.50
01-004446	ESTRADA HINOJOSA & CO	I-3753	03 597-0530	PROFESSIONAL :	CONTINUING DISCLOSUR	144821	2,000.00
VENDOR 01-004446 TOTALS							2,000.00
DEPARTMENT 597 VENUE PROJECT						TOTAL:	2,190.50
VENDOR SET 03 VENUE PROJECT FUND						TOTAL:	2,190.50

VENDOR SET: 01 City of South Padre Island

BANK: OPER

FUND : 06 CONVENTION CENTER FUND

DEPARTMENT: N/A NON-DEPARTMENTAL

INVOICE DATE RANGE: 1/01/1998 THRU 99/99/9999

PAY DATE RANGE: 6/20/2019 THRU 7/12/2019

BUDGET TO USE: CB-CURRENT BUDGET

VENDOR	NAME	ITEM #	G/L ACCOUNT	NAME	DESCRIPTION	CHECK #	AMOUNT
01-022249	VICTOR O. SCHINNERER & I-SI752781		06 1400	PREPAID EXPEN:	WINDSTORM POL 7/02/1	144804	30,669.75
						VENDOR 01-022249 TOTALS	30,669.75

DEPARTMENT	NON-DEPARTMENTAL	TOTAL:	30,669.75
------------	------------------	--------	-----------

7/10/2019 6:47 PM

REGULAR DEPARTMENT PAYMENT REPORT

PAGE: 36

VENDOR SET: 01 City of South Padre Island

BANK: OPER

FUND : 06 CONVENTION CENTER FUND

DEPARTMENT: 565 CONVENTION CENTER OPER

INVOICE DATE RANGE: 1/01/1998 THRU 99/99/9999

PAY DATE RANGE: 6/20/2019 THRU 7/12/2019

BUDGET TO USE: CB-CURRENT BUDGET

VENDOR	NAME	ITEM #	G/L ACCOUNT	NAME	DESCRIPTION	CHECK #	AMOUNT
01-001210	AIR FILTER COMPANY	I-78561	06 565-0415	SERVICE CONTR:	HVAC FILTER SERVICE	000277	292.40
							<u>292.40</u>
					VENDOR 01-001210 TOTALS		292.40
01-001217	ALAMO DOOR SYSTEMS, IN	I-36910-1	06 565-1001	BUILDINGS & S:	OVERHEAD DOOR REPLAC	144755	13,532.40
							<u>13,532.40</u>
					VENDOR 01-001217 TOTALS		13,532.40
01-003150	CAMERON COUNTY PARKS-A	I-70919	06 565-0560	CAMERON COUNT:	LEASE PAYMENT JUNE 2	144920	1,681.62
							<u>1,681.62</u>
					VENDOR 01-003150 TOTALS		1,681.62
01-003418	JAMES R. MATTHEWS	I-0719	06 565-0415	SERVICE CONTR:	WATER TREATMENT JULY	144816	150.00
							<u>150.00</u>
					VENDOR 01-003418 TOTALS		150.00
01-003419	DONNELLY HOLDINGS, LTD	I-163848	06 565-0114	MEDICAL	: MISC. FIRST AID & ME	144868	130.73
							<u>130.73</u>
					VENDOR 01-003419 TOTALS		130.73
01-003851	INTERNATIONAL PROTECT	I-190617SPI	06 565-0415	SERVICE CONTR:	SECURITY FOR CC	144818	611.88
							<u>611.88</u>
					VENDOR 01-003851 TOTALS		611.88
01-004283	ECOLAB INC.	I-1716158	06 565-0415	SERVICE CONTR:	DISHMACHINE RENT 6/0	144763	186.57
							<u>186.57</u>
					VENDOR 01-004283 TOTALS		186.57
01-005512	EXPRESS SERVICES, INC.	I-22471974	06 565-0040	TEMPORARY EMP:	TEMP LABOR CVB JUNE	144764	651.20
01-005512	EXPRESS SERVICES, INC.	I-22505996	06 565-0040	TEMPORARY EMP:	TEMP LABOR CVB 6/16/	144822	651.20
01-005512	EXPRESS SERVICES, INC.	I-22540638	06 565-0040	TEMPORARY EMP:	TEMP LABOR CVB JUNE	144871	520.96
01-005512	EXPRESS SERVICES, INC.	I-22568936	06 565-0040	TEMPORARY EMP:	TEMP LABOR CVB JUNE	144927	651.20
							<u>2,474.56</u>
					VENDOR 01-005512 TOTALS		2,474.56
01-006162	JUAN FLORES	I-0000731	06 565-0415	SERVICE CONTR:	LANDSCAPE SERVICE	000279	1,350.00
							<u>1,350.00</u>
					VENDOR 01-006162 TOTALS		1,350.00

7/10/2019 6:47 PM

REGULAR DEPARTMENT PAYMENT REPORT

PAGE: 37

VENDOR SET: 01 City of South Padre Island

BANK: OPER

FUND : 06 CONVENTION CENTER FUND

DEPARTMENT: 565 CONVENTION CENTER OPER

INVOICE DATE RANGE: 1/01/1998 THRU 99/99/9999

PAY DATE RANGE: 6/20/2019 THRU 7/12/2019

BUDGET TO USE: CB-CURRENT BUDGET

VENDOR	NAME	ITEM #	G/L ACCOUNT	NAME	DESCRIPTION	CHECK #	AMOUNT
01-007115	GEXA ENERGY, LP	I-28079672-4	06 565-0580	ELECTRICITY	: ELECTRIC BILL DATED	144876	18,579.01
VENDOR 01-007115 TOTALS							18,579.01
01-007600	GULF COAST PAPER CO. I	I-1690278	06 565-0160	LAUNDRY & JAN:	1 CS MICROFIBER CLN	144830	28.50
01-007600	GULF COAST PAPER CO. I	I-1691774	06 565-0160	LAUNDRY & JAN:	VACUUM MTR, SPRAY TI	144830	313.90
01-007600	GULF COAST PAPER CO. I	I-1693212	06 565-0160	LAUNDRY & JAN:	TISSUE, TWLS, MISC.	144830	488.31
01-007600	GULF COAST PAPER CO. I	I-1696356	06 565-0160	LAUNDRY & JAN:	GLOVES, BAGS, MISC.	144877	473.65
01-007600	GULF COAST PAPER CO. I	I-1697647	06 565-0160	LAUNDRY & JAN:	MISC. CLNSERS FOR US	144932	263.99
VENDOR 01-007600 TOTALS							1,568.35
01-011014	JUAN JOSE MORA	I-0606	06 565-0130	WEARING APPAR:	18 SPI LOGOS EMBROID	144772	126.00
01-011014	JUAN JOSE MORA	I-0608	06 565-0130	WEARING APPAR:	3-SPI LOGO EMBROIDER	144832	21.00
VENDOR 01-011014 TOTALS							147.00
01-013297	MOBILE MINI, INC	I-9006491624	06 565-1004	MACHINERY & E:	STORAGE UNIT FOR STA	144837	4,552.00
VENDOR 01-013297 TOTALS							4,552.00
01-013404	MOUNTAIN GLACIER, LLC	I-0301174524	06 565-0103-01	CONSUMABLES	: BOTTLED WATER DEL. C	144838	49.50
VENDOR 01-013404 TOTALS							49.50
01-013427	MORROW TECHNOLOGIES CO	I-MA-1907001	06 565-0415	SERVICE CONTR:	ANNUAL MAINTENANCE A	144940	431.00
VENDOR 01-013427 TOTALS							431.00
01-017997	RUBEN RAMOS	I-1372	06 565-0415	SERVICE CONTR:	PEST CONTROL CVB	144846	210.00
VENDOR 01-017997 TOTALS							210.00
01-018154	REPUBLIC SERVICES #863	I-0863001638089	06 565-0581	WATER, SEWER	: SPECIAL SERC. 7355 P	144847	385.73
01-018154	REPUBLIC SERVICES #863	I-0863001679109	06 565-0581	WATER, SEWER	: 7355 PADRE BLVD, JUL	144896	775.76
VENDOR 01-018154 TOTALS							1,161.49

7/10/2019 6:47 PM

REGULAR DEPARTMENT PAYMENT REPORT

PAGE: 38

VENDOR SET: 01 City of South Padre Island

BANK: OPER

FUND : 06 CONVENTION CENTER FUND

DEPARTMENT: 565 CONVENTION CENTER OPER

INVOICE DATE RANGE: 1/01/1998 THRU 99/99/9999

PAY DATE RANGE: 6/20/2019 THRU 7/12/2019

BUDGET TO USE: CB-CURRENT BUDGET

VENDOR NAME	ITEM #	G/L ACCOUNT	NAME	DESCRIPTION	CHECK #	AMOUNT
01-019141 SICO AMERICA INC.	I-3006650	06 565 1004	MACHINERY & E:	NEW STAGE	144947	152,686.00
VENDOR 01-019141 TOTALS						152,686.00
01-019520 AT&T	I-61819	06 565-0501	COMMUNICATION:	LONG DISTANCE SERVC.	144894	42.55
VENDOR 01-019520 TOTALS						42.55
01-019645 DARIN L. STRONG	I-4779	06 565-0410	MACHINERY & E:	REPAIR WALK-IN FREEZ	144952	1,519.41
VENDOR 01-019645 TOTALS						1,519.41
01-020057 TML MULTISTATE IEBP	I-070119	06 565-0081	GROUP INSURAN:	JULY 2019 MEDICAL PR	000289	5,205.40
VENDOR 01-020057 TOTALS						5,205.40
01-020602 TOUCAN GRAPHICS	I-26833	06 565-0101	OFFICE SUPPLI:	ART SERV. 18-X24 AL.	144955	83.41
01-020602 TOUCAN GRAPHICS	I-27049	06 565-0101	OFFICE SUPPLI:	250 BUSINESS CARDS,	144781	29.00
01-020602 TOUCAN GRAPHICS	I-27097	06 565-0101	OFFICE SUPPLI:	5- METAL NAME BADGES	144781	98.67
01-020602 TOUCAN GRAPHICS	I-27222	06 565-0101	OFFICE SUPPLI:	500 BUS CARDS, TERI	144902	39.00
VENDOR 01-020602 TOTALS						250.08
01-021102 UNIFIRST HOLDINGS, INC	I-2129982	06 565-0130	WEARING APPAR:	UNIFORMS, MATS, MOPS	000304	63.18
01-021102 UNIFIRST HOLDINGS, INC	I-2129982	06 565-0160	LAUNDRY & JAN:	UNIFORMS, MATS, MOPS	000304	126.36
01-021102 UNIFIRST HOLDINGS, INC	I-8412128183	06 565-0510	RENTAL OF EQU:	MISC TABLECOVERS (RE	000273	96.67
01-021102 UNIFIRST HOLDINGS, INC	I-8412128294	06 565-0130	WEARING APPAR:	UNIFORMS, MATS, MOPS	000284	63.18
01-021102 UNIFIRST HOLDINGS, INC	I-8412128294	06 565-0160	LAUNDRY & JAN:	UNIFORMS, MATS, MOPS	000284	143.91
01-021102 UNIFIRST HOLDINGS, INC	I-8412129149	06 565-0130	WEARING APPAR:	UNIFORMS	000293	63.18
01-021102 UNIFIRST HOLDINGS, INC	I-8412129149	06 565-0160	LAUNDRY & JAN:	MATS, MOPS, ETC	000293	126.36
VENDOR 01-021102 TOTALS						682.84
01-021226 US BANK VOYAGER FLEET	I-869326488926	06 565-0104	FUELS & LUBRI:	FUEL PURCHASED MAY 2	144909	102.50
VENDOR 01-021226 TOTALS						102.50
01-022249 VICTOR O. SCHINNERER & I-SI752781		06 565-0520	INSURANCE	: WINDSTORM POL 7/02/1	144804	10,223.25
VENDOR 01-022249 TOTALS						10,223.25

7/10/2019 6:47 PM

REGULAR DEPARTMENT PAYMENT REPORT

PAGE: 39

VENDOR SET: 01 City of South Padre Island

BANK: OPER

FUND : 06 CONVENTION CENTER FUND

DEPARTMENT: 565 CONVENTION CENTER OPER

INVOICE DATE RANGE: 1/01/1998 THRU 99/99/9999

PAY DATE RANGE: 6/20/2019 THRU 7/12/2019

BUDGET TO USE: CB-CURRENT BUDGET

VENDOR	NAME	ITEM #	G/L ACCOUNT	NAME	DESCRIPTION	CHECK #	AMOUNT
01-022254	I. T. VERDIN COMPANY	1-cinv3263	06 565-0401	FURNITURE & F:	BIKE RACKS	144910	2,890.00
						VENDOR 01-022254 TOTALS	2,890.00

DEPARTMENT 565 CONVENTION CENTER OPER TOTAL: 220,710.54

VENDOR SET 06 CONVENTION CENTER FUND TOTAL: 251,380.29

7/10/2019 6:47 PM

REGULAR DEPARTMENT PAYMENT REPORT

PAGE: 40

VENDOR SET: 01 City of South Padre Island

BANK: OPER

FUND : 08 FORFEITED PROPERTY FUND

DEPARTMENT: 521 POLICE DEPARTMENT

INVOICE DATE RANGE: 1/01/1998 THRU 99/99/9999

PAY DATE RANGE: 6/20/2019 THRU 7/12/2019

BUDGET TO USE: CB-CURRENT BUDGET

VENDOR	NAME	ITEM #	G/L ACCOUNT	NAME	DESCRIPTION	CHECK #	AMOUNT
01-023034	WATCH GUARD , INC.	I-4REINV0009262	08 521-1007	MOTOR VEHICLE:	4RE STANDARD DVR CAM	144785	5,020.00
						VENDOR 01-023034 TOTALS	5,020.00

DEPARTMENT 521 POLICE DEPARTMENT TOTAL: 5,020.00

VENDOR SET 08 FORFEITED PROPERTY FUND TOTAL: 5,020.00

7/10/2019 6:47 PM

REGULAR DEPARTMENT PAYMENT REPORT

PAGE: 41

VENDOR SET: 01 City of South Padre Island

BANK: OPER

FUND : 09 PARKS, REC & BEAUTIF

DEPARTMENT: 572 GENERAL SERVICES

INVOICE DATE RANGE: 1/01/1998 THRU 99/99/9999

PAY DATE RANGE: 6/20/2019 THRU 7/12/2019

BUDGET TO USE: CB-CURRENT BUDGET

VENDOR	NAME	ITEM #	G/L ACCOUNT	NAME	DESCRIPTION	CHECK #	AMOUNT
01-003444	CITIBANK	I-60319	09 572-0551	DUES & MEMBER:	TX REC & PARK SOCIET	144805	545.00-
						VENDOR 01-003444 TOTALS	545.00-
01-006111	AIM MEDIA TEXAS OPERAT	I-10022472-0619	09 572-0540	ADVERTISING :	DISPLAY AD, COASTAL	144928	400.00
						VENDOR 01-006111 TOTALS	400.00
01-020057	TML MULTISTATE IEBP	I-070119	09 572-0081	GROUP INSURAN:	JULY 2019 MEDICAL PR	000289	520.54
						VENDOR 01-020057 TOTALS	520.54

DEPARTMENT 572 GENERAL SERVICES TOTAL: 375.54

VENDOR SET 09 PARKS, REC & BEAUTIF TOTAL: 375.54

7/10/2019 6:47 PM

REGULAR DEPARTMENT PAYMENT REPORT

PAGE: 42

VENDOR SET: 01 City of South Padre Island

BANK: OPER

FUND : 21 MUN. COURT TECHNOLOGY

DEPARTMENT: 520 MUN COURT TECHNOLOGY

INVOICE DATE RANGE: 1/01/1998 THRU 99/99/9999

PAY DATE RANGE: 6/20/2019 THRU 7/12/2019

BUDGET TO USE: CB-CURRENT BUDGET

VENDOR	NAME	ITEM #	G/L ACCOUNT	NAME	DESCRIPTION	CHECK #	AMOUNT
01-009117	TYLER TECHNOLOGIES INC	I-025-263859	21 520-0415	SERVICE CONTR:	MONTHLY FEE TO SUPPO	144882	175.00
						VENDOR 01-009117 TOTALS	175.00
01-023900	XEROX CORPORATION	I-097091978	21 520-0510	RENTAL OF EQU:	PRINTER/COPIER LEASE	144788	283.65
						VENDOR 01-023900 TOTALS	283.65
						DEPARTMENT 520 MUN COURT TECHNOLOGY TOTAL:	458.65
						VENDOR SET 21 MUN. COURT TECHNOLOGY TOTAL:	458.65

7/10/2019 6:47 PM

REGULAR DEPARTMENT PAYMENT REPORT

PAGE: 43

VENDOR SET: 01 City of South Padre Islan

BANK: OPER

FUND : 30 TRANSPORTATION

DEPARTMENT: N/A NON-DEPARTMENTAL

INVOICE DATE RANGE: 1/01/1998 THRU 99/99/9999

PAY DATE RANGE: 6/20/2019 THRU 7/12/2019

BUDGET TO USE: CB-CURRENT BUDGET

VENDOR	NAME	ITEM #	G/L ACCOUNT	NAME	DESCRIPTION	CHECK #	AMOUNT
01-022249	VICTOR O. SCHINNERER & I-SI752781		30 1400		PREPAID EXPEN: WINDSTORM POL 7/02/1	144804	32,983.32
						VENDOR 01-022249 TOTALS	32,983.32

DEPARTMENT	NON-DEPARTMENTAL	TOTAL:
		32,983.32

VENDOR SET: 01 City of South Padre Island

BANK: OPER

FUND : 30 TRANSPORTATION

DEPARTMENT: 591 SPI METRO

INVOICE DATE RANGE: 1/01/1998 THRU 99/99/9999

PAY DATE RANGE: 6/20/2019 THRU 7/12/2019

BUDGET TO USE: CB-CURRENT BUDGET

VENDOR	NAME	ITEM #	G/L ACCOUNT	NAME	DESCRIPTION	CHECK #	AMOUNT
01-001006	GREGORY D. ALEXANDER	I-671055	30 591-0420	MOTOR VEHICLE: 12- BLISTER PK CAPSU	144806	158.52	
01-001006	GREGORY D. ALEXANDER	I-671262	30 591-0420	MOTOR VEHICLE: HYD HOSE, CLAMP, UNI	144806	18.07	
01-001006	GREGORY D. ALEXANDER	I-671362	30 591-0420	MOTOR VEHICLE: 1- QUICK COOL FREON,	144806	29.99	
01-001006	GREGORY D. ALEXANDER	I-671582	30 591-0420	MOTOR VEHICLE: 1- OXYG. SENSOR FOR	144865	64.25	
01-001006	GREGORY D. ALEXANDER	I-671654	30 591-0420	MOTOR VEHICLE: HTR HOSE, CLMP, CONN.	144865	32.82	
01-001006	GREGORY D. ALEXANDER	I-672083	30 591-0420	MOTOR VEHICLE: BRAKE PADS UNIT #40	144865	67.40	
01-001006	GREGORY D. ALEXANDER	I-672268	30 591-0150	MINOR TOOLS &: 1- 12P OPS WR TOOL	144865	10.05	
01-001006	GREGORY D. ALEXANDER	I-672269	30 591-0420	MOTOR VEHICLE: TRANSMISSION ASSY	144865	2,602.38	
VENDOR 01-001006 TOTALS						2,983.48	
01-001123	ADVANCE AUTO PARTS	I-6426915065783	30 591-0420	MOTOR VEHICLE: OIL SEALS, BEARINGS,	144807	112.98	
01-001123	ADVANCE AUTO PARTS	I-6426916166020	30 591-0420	MOTOR VEHICLE: 1- FLTRUN MICRO B S	144807	38.85	
01-001123	ADVANCE AUTO PARTS	I-6426916866241	30 591-0420	MOTOR VEHICLE: 6- GL XTREME BLUE DE	144807	16.50	
01-001123	ADVANCE AUTO PARTS	I-6426916924234	30 591-0420	MOTOR VEHICLE: ATF. FOR METRO STOCK	144807	274.68	
VENDOR 01-001123 TOTALS						443.01	
01-001129	A & W OFFICE SUPPLY IN	I-635701-0	30 591-0160	LAUNDRY & JAN: FACIAL AND BATHROOM	144808	177.42	
VENDOR 01-001129 TOTALS						177.42	
01-001175	A-PRO TOWING & RECOVER	I-0617001	30 591-0420	MOTOR VEHICLE: TOWED UNIT #37 FROM	144809	325.00	
VENDOR 01-001175 TOTALS						325.00	
01-001359	JESUS ARRIAGA	I-052919	30 591-0550	TRAVEL EXPENS: PER DIEM: AUSTIN JUN	000274	120.00	
01-001359	JESUS ARRIAGA	I-70119	30 591-0550	TRAVEL EXPENS: REIMBURSE FOR GROUND	000299	57.32	
VENDOR 01-001359 TOTALS						177.32	
01-001985	JIM CORBETT DBA BACK	I-91681	30 591-0520	PROFESSIONAL : BACK FLOW PREVENTER	144810	118.00	
VENDOR 01-001985 TOTALS						118.00	
01-003226	DEBORAH CARPENTER	I-61119	30 591-0550	TRAVEL EXPENS: MILEAGE REIMBURSEMEN	144758	94.24	
VENDOR 01-003226 TOTALS						94.24	

VENDOR SET: 01 City of South Padre Island

BANK: OPER

FUND : 30 TRANSPORTATION

DEPARTMENT: 591 SPI METRO

INVOICE DATE RANGE: 1/01/1998 THRU 99/99/9999

PAY DATE RANGE: 6/20/2019 THRU 7/12/2019

BUDGET TO USE: CB-CURRENT BUDGET

VENDOR NAME	ITEM #	G/L ACCOUNT	NAME	DESCRIPTION	CHECK #	AMOUNT
01-003444 CITIBANK	I-60319	30 591-0533	MARKETING	SALES TAX CREDIT TRA	144805	27.28
VENDOR 01-003444 TOTALS						27.28
01-006034 FED EX	I-6-589-55269	30 591-0108	POSTAGE	MISC. SHIPPING CHARG	144823	71.32
VENDOR 01-006034 TOTALS						71.32
01-007115 GEXA ENERGY, LP	I-28079672-4	30 591-0580	ELECTRICITY	ELECTRIC BILL DATED	144876	883.14
01-007115 GEXA ENERGY, LP	I-28079674-4	30 591-0580	ELECTRICITY	3401 PADRE BLVD 5/13	144931	176.68
01-007115 GEXA ENERGY, LP	I-28079674-4	30 591-0580	ELECTRICITY	321 PADRE BLVD 5/7 -	144931	1,255.80
VENDOR 01-007115 TOTALS						2,315.62
01-008145 OMAR HERNANDEZ	I-1271	30 591-0501	COMMUNICATION:	CAMERA INSTALL	144878	2,555.00
VENDOR 01-008145 TOTALS						2,555.00
01-012071 LAGUNA MADRE WATER DIS	I-060719-56	30 591-0581	WTR/SWR/GARBA:	321 PADRE BLVD 4/30-	000288	298.46
01-012071 LAGUNA MADRE WATER DIS	I-060719-57	30 591-0581	WTR/SWR/GARBA:	321 PADRE BLVD IRRIG	000288	435.57
01-012071 LAGUNA MADRE WATER DIS	I-060719-58	30 591-0581	WTR/SWR/GARBA:	321 PADRE BLVD F/L	000288	50.25
VENDOR 01-012071 TOTALS						784.28
01-012091 CINTAS UNIFORM	I-4023594268	30 591-0130	WEARING APPAR:	UNIFORMS TRANSIT DRJ	144774	119.58
01-012091 CINTAS UNIFORM	I-4024031741	30 591-0130	WEARING APPAR:	UNIFORMS FOR TRANSIT	144834	119.58
01-012091 CINTAS UNIFORM	I-4024504572	30 591-0130	WEARING APPAR:	UNIFORMS FOR TRANSIT	144885	119.58
01-012091 CINTAS UNIFORM	I-4025057052	30 591-0130	WEARING APPAR:	UNIFORMS FOR TRANSIT	144885	119.58
VENDOR 01-012091 TOTALS						478.32
01-013014 LIDIA MARTINEZ	I-51519	30 591-0551	DUE & MEMBERS:	REIMBURSE FOR MEDICA	144835	82.00
VENDOR 01-013014 TOTALS						82.00
01-013404 MOUNTAIN GLACIER, LLC	I-0301172691	30 591-0581	WTR/SWR/GARBA:	BOTTLED WATER DEL. T	144838	11.25
01-013404 MOUNTAIN GLACIER, LLC	I-0301176322	30 591-0581	WTR/SWR/GARBA:	BOTTLED WATER DEL.	144887	44.50
VENDOR 01-013404 TOTALS						55.75

VENDOR SET: 01 City of South Padre Islan

BANK: OPER

FUND : 30 TRANSPORTATION

DEPARTMENT: 591 SPI METRO

INVOICE DATE RANGE: 1/01/1998 THRU 99/99/9999

PAY DATE RANGE: 6/20/2019 THRU 7/12/2019

BUDGET TO USE: CB-CURRENT BUDGET

VENDOR NAME	ITEM #	G/L ACCOUNT	NAME	DESCRIPTION	CHECK #	AMOUNT
01-018154 REPUBLIC SERVICES #863	I-0863001677421	30 591-0581	WTR/SWR/GARBA:	321 PADRE BLVD TRANS	144945	284.82
VENDOR 01-018154 TOTALS						284.82
01-019991 RHONDA M. LUNSFORD	I-20191050	30 591-0130	WEARING APPAR:	CAPS	144853	600.00
VENDOR 01-019991 TOTALS						600.00
01-020057 TML MULTISTATE IEBP	I-070119	30 591-0081	GROUP INSURAN:	JULY 2019 MEDICAL PR	000289	7,297.56
VENDOR 01-020057 TOTALS						7,297.56
01-020185 TIME WARNER CABLE	I-0298749061419	30 591-0501	COMMUNICATION:	321 PADRE BLVD, 6/14	144899	109.99
VENDOR 01-020185 TOTALS						109.99
01-020203 TIPTON MOTORS, INC	C-156577	30 591-0420	MOTOR VEHICLE:	BRAKE CALIPERS S/B P	000000	499.00
01-020203 TIPTON MOTORS, INC	I-156577	30 591-0420	MOTOR VEHICLE:	BRAKE CALIPER UNTI #	000000	499.00
VENDOR 01-020203 TOTALS						0.00
01-020235 TEXAS ALCOHOL & DRUG T	I-166418	30 591-0528	LICENSING & T:	MOBILE DRUG SCREENIN	144900	327.26
01-020235 TEXAS ALCOHOL & DRUG T	I-166419	30 591-0528	LICENSING & T:	MISC. TESTING MAY 2	144856	204.50
VENDOR 01-020235 TOTALS						531.76
01-020602 TOUCAN GRAPHICS	I-26934	30 591-0533	MARKETING :	MISC. INVITES, ETC M	144902	251.00
01-020602 TOUCAN GRAPHICS	I-27069	30 591-0533	MARKETING :	200- SUNGLASSES- GI	144902	497.46
VENDOR 01-020602 TOTALS						748.46
01-021082 ULINE	I-1094525.99	30 591-0150	MINOR TOOLS & :	TRASH BARRELS	144905	782.88
VENDOR 01-021082 TOTALS						782.88
01-021226 US BANK VOYAGER FLEET	I-869326488926	30 591-0104	FUELS & LUBRI:	FUEL PURCHASED MAY 2	144909	11,505.77
VENDOR 01-021226 TOTALS						11,505.77

7/10/2019 6:47 PM

REGULAR DEPARTMENT PAYMENT REPORT

PAGE: 47

VENDOR SET: 01 City of South Padre Island

BANK: OPER

FUND : 30 TRANSPORTATION

DEPARTMENT: 591 SPI METRO

INVOICE DATE RANGE: 1/01/1998 THRU 99/99/9999

PAY DATE RANGE: 6/20/2019 THRU 7/12/2019

BUDGET TO USE: CB-CURRENT BUDGET

VENDOR	NAME	ITEM #	G/L ACCOUNT	NAME	DESCRIPTION	CHECK #	AMOUNT
01-022249	VICTOR O. SCHINNERER & I-SI752781		30 591-0520	INSURANCE	: WINDSTORM POL 7/02/1	144804	10,994.44
						VENDOR 01-022249 TOTALS	10,994.44
01-1	TRIPLE THREAT CLEANING I-10261		30 591-0530	PROFESSIONAL	: TRIPLE THREAT CLEANI	144861	200.00
01-1	TRIPLE THREAT CLEANING I-10265		30 591-0530	PROFESSIONAL	: TRIPLE THREAT CLEANI	144964	200.00
						VENDOR 01-1 TOTALS	400.00
						DEPARTMENT 591 SPI METRO	TOTAL: 43,889.15
						VENDOR SET 30 TRANSPORTATION	TOTAL: 76,872.47

7/10/2019 6:47 PM

REGULAR DEPARTMENT PAYMENT REPORT

PAGE: 48

VENDOR SET: 01 City of South Padre Island

BANK: OPER

FUND : 41 PADRE BLVD IMPROVEMENT

DEPARTMENT: 562 PUBLIC WORKS

INVOICE DATE RANGE: 1/01/1998 THRU 99/99/9999

PAY DATE RANGE: 6/20/2019 THRU 7/12/2019

BUDGET TO USE: CB-CURRENT BUDGET

VENDOR	NAME	ITEM #	G/L ACCOUNT	NAME	DESCRIPTION	CHECK #	AMOUNT
01-011149	KIMLEY-HORN & ASSOCIAT	I-069234002-0419	41 562-0530	PROFESSIONAL	: PADRE BLVD. PHASE I	000271	9,293.98
						VENDOR 01-011149 TOTALS	9,293.98

DEPARTMENT 562 PUBLIC WORKS TOTAL: 9,293.98

VENDOR SET 41 PADRE BLVD IMPROVEMENT TOTAL: 9,293.99

7/10/2019 6:47 PM

REGULAR DEPARTMENT PAYMENT REPORT

PAGE: 49

VENDOR SET: 01 City of South Padre Island

BANK: OPER

FUND : 50 GENERAL DEBT SERVICE

DEPARTMENT: 567 DEBT SERVICE

INVOICE DATE RANGE: 1/01/1998 THRU 99/99/9999

PAY DATE RANGE: 6/20/2019 THRU 7/12/2019

BUDGET TO USE: CB-CURRENT BUDGET

VENDOR	NAME	ITEM #	G/L ACCOUNT	NAME	DESCRIPTION	CHECK #	AMOUNT
01-001991	THE BANK OF NEW YORK M	I-252-2206756	50 567-0623	PAYING AGENT	PAYING AGENT FEE, JU 144811		750.00
						VENDOR 01-001991 TOTALS	750.00

DEPARTMENT 567	DEBT SERVICE	TOTAL:	750.00
----------------	--------------	--------	--------

VENDOR SET 50	GENERAL DEBT SERVICE	TOTAL:	750.00
---------------	----------------------	--------	--------

7/10/2019 6:47 PM

REGULAR DEPARTMENT PAYMENT REPORT

PAGE: 50

VENDOR SET: 01 City of South Padre Islan

BANK: OPER

FUND : 53 VENUE DEBT SERVICE

DEPARTMENT: 597 ** INVALID DEPT **

INVOICE DATE RANGE: 1/01/1998 THRU 99/99/9999

PAY DATE RANGE: 6/20/2019 THRU 7/12/2019

BUDGET TO USE: CB-CURRENT BUDGET

VENDOR	NAME	ITEM #	G/L ACCOUNT	NAME	DESCRIPTION	CHECK #	AMOUNT
01-001991	THE BANK OF NEW YORK M	I-252-2206774	53 597-0623	PAYING AGENT :	PAYING AGENT FEE: HO	144812	800.00
						VENDOR 01-001991 TOTALS	800.00

DEPARTMENT 597 ** INVALID DEPT ** TOTAL: 800.00

VENDOR SET 53 VENUE DEBT SERVICE TOTAL: 800.00

7/10/2019 6:47 PM

REGULAR DEPARTMENT PAYMENT REPORT

PAGE: 51

VENDOR SET: 01 City of South Padre Islan

BANK: OPER

FUND : 60 BEACH MAINTENANCE FUND

DEPARTMENT: N/A NON-DEPARTMENTAL

INVOICE DATE RANGE: 1/01/1998 THRU 99/99/9999

PAY DATE RANGE: 6/20/2019 THRU 7/12/2019

BUDGET TO USE: CB-CURRENT BUDGET

VENDOR	NAME	ITEM #	G/L ACCOUNT	NAME	DESCRIPTION	CHECK #	AMOUNT		
01-022249	VICTOR O. SCHINNERER & I-SI752781		60 1400	PREPAID EXPEN:	WINDSTORM POL 7/02/1	144804	168.36		
						VENDOR 01-022249 TOTALS	168.36		
						DEPARTMENT	NON-DEPARTMENTAL	TOTAL:	168.36

7/10/2019 6:47 PM

REGULAR DEPARTMENT PAYMENT REPORT

PAGE: 52

VENDOR SET: 01 City of South Padre Islan

BANK: OPER

FUND : 60 BEACH MAINTENANCE FUND

DEPARTMENT: 521 POLICE

INVOICE DATE RANGE: 1/01/1998 THRU 99/99/9999

PAY DATE RANGE: 6/20/2019 THRU 7/12/2019

BUDGET TO USE: CB-CURRENT BUDGET

VENDOR	NAME	ITEM #	G/L ACCOUNT	NAME	DESCRIPTION	CHECK #	AMOUNT
01-020057	TML MULTISTATE IEBP	1-070119	60 521-0081	GROUP INSURAN:	JULY 2019 MEDICAL PR	000289	132.64
						VENDOR 01-020057 TOTALS	132.64
						DEPARTMENT 521 POLICE	TOTAL: 132.64

VENDOR SET: 01 City of South Padre Islan

BANK: OPER

FUND : 60 BEACH MAINTENANCE FUND

DEPARTMENT: 522 BEACH PATROL

INVOICE DATE RANGE: 1/01/1998 THRU 99/99/9999

PAY DATE RANGE: 6/20/2019 THRU 7/12/2019

BUDGET TO USE: CB-CURRENT BUDGET

VENDOR	NAME	ITEM #	G/L ACCOUNT	NAME	DESCRIPTION	CHECK #	AMOUNT
01-007398	GRAMB INC.	I-0619019-1	60 522-1007	VEHICLES	: 2019 MAHINDRA ROXOR	144829	17,775.81
					VENDOR 01-007398 TOTALS		17,775.81
01-019313	SPI BIRDING AND NATURE	I-062119	60 522-0513	TRAINING EXPE:	JR. LIFE GUARDS FIEL	144852	143.00
					VENDOR 01-019313 TOTALS		143.00
01-020057	TML MULTISTATE IEBP	I-070110	60 522-0081	GROUP INSURAN:	JULY 2019 MEDICAL PR	000289	650.67
					VENDOR 01-020057 TOTALS		650.67
01-021226	US BANK VOYAGER FLEET	I-069326488926	60 522-0104	FUEL & LUBRIC:	FUEL PURCHASED MAY 2	144909	736.72
					VENDOR 01-021226 TOTALS		736.72
01-022249	VICTOR O. SCHINNERER &	I-SI752781	60 522-0520	INSURANCE	: WINDSTORM POL 7/02/1	144804	56.12
					VENDOR 01-022249 TOTALS		56.12
01-1	UTRGV	I-62619	60 522-0513	TRAINING EXPE:	UTRGV: SHARK DISSECT	144914	241.00
					VENDOR 01-1 TOTALS		241.00

DEPARTMENT 522 BEACH PATROL TOTAL: 19,603.32

VENDOR SET: 01 City of South Padre Islan

BANK: OPER

FUND : 60 BEACH MAINTENANCE FUND

DEPARTMENT: 532 ENVIRONMENTAL HEALTH

INVOICE DATE RANGE: 1/01/1998 THRU 99/99/9999

PAY DATE RANGE: 6/20/2019 THRU 7/12/2019

BUDGET TO USE: CB-CURRENT BUDGET

VENDOR	NAME	ITEM #	G/L ACCOUNT	NAME	DESCRIPTION	CHECK #	AMOUNT
01-001211	ALEX AVALOS PRINTING	I-7219	60 532-0118	PRINTING	: 1250 CITATIONS PRINT	144866	446.13
VENDOR 01-001211 TOTALS							446.13
01-007398	GRAMB INC.	I-0619019	60 532-1007	MOTOR VEHICLE:	2019 CAN AM DEFENDER	144829	14,167.40
VENDOR 01-007398 TOTALS							14,167.40
01-020057	TML MULTISTATE IEBP	I-070119	60 532-0081	GROUP INSURAN:	JULY 2019 MEDICAL PR	000289	79.58
VENDOR 01-020057 TOTALS							79.58
DEPARTMENT 532 ENVIRONMENTAL HEALTH						TOTAL:	14,693.11

VENDOR SET: 01 City of South Padre Island

BANK: OPER

FUND : 60 BEACH MAINTENANCE FUND

DEPARTMENT: 560 BEACH MAINTENANCE

INVOICE DATE RANGE: 1/01/1998 THRU 99/99/9999

PAY DATE RANGE: 6/20/2019 THRU 7/12/2019

BUDGET TO USE: CB-CURRENT BUDGET

VENDOR	NAME	ITEM #	G/L	ACCOUNT	NAME	DESCRIPTION	CHECK #	AMOUNT
01-003444	CITIBANK	I-60319	60	560-0401	FURNITURE & F:	SHORELINE SALES TAX	144805	76.46-
01-003444	CITIBANK	I-60319	60	560-0510	BEACH MAINTEN:	SHORELINE ITEM RETUR	144805	288.76-
							VENDOR 01-003444 TOTALS	365.22-
01-003697	ANRIGE INC.	I-33891.7.50	60	560-0560	RENTAL	: Portable Restroom Re	144921	13,482.24
01-003697	ANRIGE INC.	I-34261.4.21	60	560-0560	RENTAL	: Summer Portable Rest	144760	4,436.30
01-003697	ANRIGE INC.	I-34665.1.3	60	560-0560	RENTAL	: Second Restroom Serv	144921	6,240.00
							VENDOR 01-003697 TOTALS	24,158.54
01-003853	COASTAL TRANSPLANTS, I	I-1720	60	560-0510	BEACH MAINTEN:	10,600 PLANTS FOR DU	144819	6,360.00
							VENDOR 01-003853 TOTALS	6,360.00
01-004133	DENTON NAVARRO ROCHA B	I-25003	60	560-0530	PROFESSIONAL :	LEGAL SERV: RE; LA C	144925	666.00
							VENDOR 01-004133 TOTALS	666.00
01-006182	FOCUSED ADVOCACY,LLC	I-39878	60	560-0530	PROFESSIONAL SERVICES		144765	8,683.33
01-006182	FOCUSED ADVOCACY,LLC	I-39924	60	560-0530	PROFESSIONAL SERVICES		144929	8,683.33
							VENDOR 01-006182 TOTALS	17,366.66
01-007600	GULF COAST PAPER CO. I	I-1642632	60	560-0510	BEACH MAINTEN:	1 CS. ROLL TWLS, BEA	144932	62.21
							VENDOR 01-007600 TOTALS	62.23
01-012091	CINTAS UNIFORM	I-4023594315	60	560-0130	WEARING APPAR:	UNIFORMS FOR SHORELI	144774	146.56
01-012091	CINTAS UNIFORM	I-4024031802	60	560-0530	PROFESSIONAL :	UNIFORMS, SHORELINE	144834	146.56
01-012091	CINTAS UNIFORM	I-4024504538	60	560-0530	PROFESSIONAL :	UNIFORMS FOR SHORELI	144885	146.56
01-012091	CINTAS UNIFORM	I-4025057043	60	560-0530	PROFESSIONAL :	UNIFORMS FOR SHOREL	144937	146.56
							VENDOR 01-012091 TOTALS	586.24
01-016110	PADRE ISLAND'S ACE HAR	C-B09207	60	560-0420	MOTOR VEHICLE:	CORRECTION S/B P CAR	000000	2.50-
01-016110	PADRE ISLAND'S ACE HAR	I-B09207	60	560-0420	MOTOR VEHICLE:	STRAP BOLTS, UNIT BM	000000	2.50
							VENDOR 01-016110 TOTALS	0.00

VENDOR SET: 01 City of South Padre Island

BANK: OPER

FUND : 60 BEACH MAINTENANCE FUND

DEPARTMENT: 560 BEACH MAINTENANCE

INVOICE DATE RANGE: 1/01/1998 THRU 99/99/9999

PAY DATE RANGE: 6/20/2019 THRU 7/12/2019

BUDGET TO USE: CB-CURRENT BUDGET

VENDOR	NAME	ITEM #	G/L ACCOUNT	NAME	DESCRIPTION	CHECK #	AMOUNT
01-018154	REPUBLIC SERVICES #863	I-0863001669122	60 560-0510	BEACH MAINTEN:	7355 PADRE BLVD SPEC	144847	1,860.93
VENDOR 01-018154 TOTALS							1,860.93
01-020057	TML MULTISTATE IEBP	I-070119	60 560-0081	GROUP INSURAN:	JULY 2019 MEDICAL PR	000289	3,201.82
VENDOR 01-020057 TOTALS							3,201.82
01-020602	TOUCAN GRAPHICS	I-27120	60 560-0101	OFFICE SUPPLI:	250 BUSINESS CARD, K	144857	29.00
01-020602	TOUCAN GRAPHICS	I-27219	60 560-0101	OFFICE SUPPLI:	250 BUS. CARDS, ERIK	144902	29.00
VENDOR 01-020602 TOTALS							58.00
01-021226	US BANK VOYAGER FLEET	I-869326488926	60 560-0104	FUEL & LUBRIC:	FUEL PURCHASED MAY 2	144909	1,617.61
VENDOR 01-021226 TOTALS							1,617.61

DEPARTMENT 560 BEACH MAINTENANCE TOTAL: 55,572.81

VENDOR SET 60 BEACH MAINTENANCE FUND TOTAL: 90,170.24

VENDOR SET: 01 City of South Padre Islan

BANK: OPER

FUND : 62 BAY ACCESS FUND

DEPARTMENT: 560 SHORELINE

INVOICE DATE RANGE: 1/01/1998 THRU 99/99/9999

PAY DATE RANGE: 6/20/2019 THRU 7/12/2019

BUDGET TO USE: CB-CURRENT BUDGET

VENDOR	NAME	ITEM #	G/L ACCOUNT	NAME	DESCRIPTION	CHECK #	AMOUNT
01-020057	TML MULTISTATE IEBP	I-070119	62 560-0081	GROUP INSURAN:	JULY 2019 MEDICAL PR	000289	520.54
						VENDOR 01-020057 TOTALS	520.54
						DEPARTMENT 560 SHORELINE TOTAL:	520.54
						VENDOR SET 62 BAY ACCESS FUND TOTAL:	520.54

VENDOR SET: 01 City of South Padre Island
 FUND : 80 ECONOMIC DEVELOPMENT CORP
 DEPARTMENT: 580 EDC
 INVOICE DATE RANGE: 1/01/1998 THRU 99/99/9999
 PAY DATE RANGE: 6/20/2019 THRU 7/12/2019
 BUDGET TO USE: CB-CURRENT BUDGET

VENDOR NAME ITEM # G/L ACCOUNT NAME DESCRIPTION CHECK # AMOUNT

01-004133 DENTON NAVARRO ROCHA B I-025006 80 580-0530 PROFESSIONAL : EDC: PROF SERVICES M 144925 353.50

VENDOR 01-004133 TOTALS 353.50

01-004446 ESTRADA HINOJOSA & CO I-3761 80 580-0530 PROFESSIONAL : EDC: CONTINUING DISC 144870 4,000.00

VENDOR 01-004446 TOTALS 4,000.00

01-012097 DARLA LAPEYRE I-70519 80 580-0102 LOCAL MEETING: 6/25/19 M GOVT AFFAI 000306 12.27

01-012097 DARLA LAPEYRE I-70519 80 580-0102 LOCAL MEETING: 6/14/19= REL ART INC 000306 26.07

01-012097 DARLA LAPEYRE I-70519 80 580-0102 LOCAL MEETING: 6/24/19 CHAMBER QTLY 000306 20.00

VENDOR 01-012097 TOTALS 58.34

01-013430 AVENU MUNISERVICES I-IN06-006424 80 580-0530 PROFESSIONAL : EDC: CLEARVIEW SERVIC 144941 755.00

VENDOR 01-013430 TOTALS 765.00

01-016651 PORT ISABELL ROTARY CLU I-633 80 580-0555 PROMOTIONS : EDC: ROTARY FLAG PRO 144845 125.00

VENDOR 01-016651 TOTALS 125.00

01-020057 TML MULTISTATE IEBB I-070119 80 580-0081 GROUP INSURAN: JULY 2019 MEDICAL PR 000289 520.54

VENDOR 01-020057 TOTALS 520.54

01-020602 TOUCAN GRAPHICS I-27079 80 580-9178 DESIGNATED PR: EDC: 2- BIG CHECKS F 144781 54.00

VENDOR 01-020602 TOTALS 54.00

01-021232 GATEWAY PRINTING & OFF I-4836756-0 80 580-0101 OFFICE SUPPLI: EDC: COPY PAPER, FLD 144958 126.42

VENDOR 01-021232 TOTALS 126.42

01-1 AMEGY BANK CORPORATE T I-6719 80 580-0530 PROFESSIONAL : AMEGY BANK CORPORATE 144801 400.00

VENDOR 01-1 TOTALS 400.00

DEPARTMENT 580 EDC TOTAL: 6,402.80

VENDOR SET: 01 City of South Padre Island

BANK: OPER

FUND : 80 ECONOMIC DEVELOPMENT CORP

DEPARTMENT: 583 BNC BUILDING FACILITY

INVOICE DATE RANGE: 1/01/1998 THRU 99/99/9999

PAY DATE RANGE: 6/20/2019 THRU 7/12/2019

BUDGET TO USE: CB-CURRENT BUDGET

VENDOR	NAME	ITEM #	G/L ACCOUNT	NAME	DESCRIPTION	CHECK #	AMOUNT
01-007115	GEXA ENERGY, LP	I-28079672-4	80 583-0580	ELECTRICITY	: ELECTRIC BILL DATED	144876	1,205.48
VENDOR 01-007115 TOTALS							1,205.48
01-011145	KONE, INC.	I-959294057	80 583-0411	BUILDINGS & S:	EDC:QTRLY MAINTENANC	144935	1,219.17
VENDOR 01-011145 TOTALS							1,219.17
01-019313	SPI BIRDING AND NATURE I-	62719	80 583-0411	BUILDINGS & S:	EDC: REIMBURSE BNC F	144892	85.00
VENDOR 01-019313 TOTALS							86.00

DEPARTMENT 583 BNC BUILDING FACILITY TOTAL: 2,510.65

VENDOR SET 80 ECONOMIC DEVELOPMENT CORPTOTAL: 8,913.45

REPORT GRAND TOTAL: 1,010,917.47

**CITY OF SOUTH PADRE ISLAND
CITY COUNCIL MEETING
AGENDA REQUEST FORM**

MEETING DATE: July 17, 2019

NAME & TITLE: Crystal Vasquez, Court Administrator
Wendi Delgado, Administrative Services Director

DEPARTMENT: Administrative Services

ITEM

Approve a budget amendment for \$7,000 for professional services to conduct Phase 2 (final phase) of the internal Municipal Court audit.

ITEM BACKGROUND

The Municipal Court staff requested an outside audit by a third party in 2018. The objective was to achieve operation effectiveness and efficiency, and assure reliable and accurate financial reporting in compliance with state and local law, regulations and policies.

This is a continuation of the audit that was started in the summer of 2018. At the time, funds were only available to complete one half of the audit. Staff is requesting \$7000 to complete the final phase of the audit. Only 50% of court processes were reviewed during the 1st phase.

The auditor not only conducts the audit but also provides training to the court staff and corrects any deficiencies that are found along the way.

Phase 1 of the Municipal Court Audit was completed in September of 2018.

BUDGET/FINANCIAL SUMMARY

\$890,000 in Excess Reserves
\$7,000 requested: 01-520-0530

COMPREHENSIVE PLAN GOAL

Chapter VII: Policy 1.2.6

LEGAL REVIEW

Sent to Legal: YES: _____
Approved by Legal: YES: _____

NO: x _____
NO: _____

RECOMMENDATIONS/COMMENTS

Staff recommends approval.

**CITY OF SOUTH PADRE ISLAND
CITY COUNCIL MEETING
AGENDA REQUEST FORM**

MEETING DATE: July 17, 2019

NAME & TITLE: Kerry Schwartz, Council Member

DEPARTMENT: City Council

ITEM

Approve excused absence request for Council Member Kerry Schwartz from the July 10, 2019 City Council special meeting.

ITEM BACKGROUND

BUDGET/FINANCIAL SUMMARY

COMPREHENSIVE PLAN GOAL

LEGAL REVIEW

Sent to Legal: YES: _____ NO: _____
Approved by Legal: YES: _____ NO: _____

Comments:

RECOMMENDATIONS/COMMENTS

7-13

**CITY OF SOUTH PADRE ISLAND
CITY COUNCIL MEETING
AGENDA REQUEST FORM**

MEETING DATE: July 17, 2019

NAME & TITLE: Aaron Hanley, Planning Director
David Travis, Building Official

DEPARTMENT: Planning Department

ITEM

Approve second and final reading of Ordinance No. 19-10 amending Chapter 4 by repealing and replacing Section 4-17 and 4-18 to provide regulations regarding substandard structures, create a review board to provide for public hearings and remediation regarding the same and dealing with related matters.

ITEM BACKGROUND

This item was presented at the May 1, 2019, City Council Meeting, where a motion was made to allow staff to work with the legal team to develop an ordinance to address substandard buildings and/or unfinished construction. The intent of the ordinance is to beautify the City of South Padre Island and to properly enforce the currently adopted version of the International Property Maintenance Code, Chapter 214 of the Local Government Code, and the Standard Unsafe Building Abatement Code. First reading of Ordinance No. 19-10 was approved by City Council at the June 19, 2019 meeting.

BUDGET/FINANCIAL SUMMARY

N/A

COMPREHENSIVE PLAN GOAL

- Chapter I Land Use, GOAL 2: The City should continue to monitor, protect, and evaluate development and resource conservation.
 - Objective 2.1: City ordinances should be consistent with the Comprehensive Plan.
 - Policy 2.1.1: The City should continue to enforce ordinances and regulations consistently and equally. Strategy 2.1.1.1: Regulations and development standards should be user-friendly and serve to streamline the permitting process while “raising the bar” of standards of development quality.

- Chapter IV Economic Development, GOAL 3: The City shall support an environment that is friendly to residents, tourists, and businesses.
 - Objective 3.1: The City should support ordinances, events, and policies that enhance the Island's economic development potential.

LEGAL REVIEW

Sent to Legal: YES: _____ NO: _____
Approved by Legal: YES: _____ NO: _____

Comments:

RECOMMENDATIONS/COMMENTS

Staff and legal team have worked together to prepare this ordinance amendment that will address the needs of the City of South Padre Island, and provide a direct approach to addressing substandard structures.

ORDINANCE NO. 19-10

AN ORDINANCE OF THE CITY OF SOUTH PADRE ISLAND, TEXAS, AMENDING CHAPTER 4 OF THE CITY CODE OF ORDINANCES (BUILDINGS AND CONSTRUCTION) BY REPEALING AND REPLACING SECTION 4-17 AND 4-18 TO PROVIDE REGULATIONS REGARDING SUBSTANDARD STRUCTURES, CREATE A REVIEW BOARD TO PROVIDE FOR PUBLIC HEARINGS AND REMEDIATION REGARDING THE SAME, AND DEALING WITH RELATED MATTERS

WHEREAS, Chapter 214 of the Texas Local Government Code empowers the City Council of the City of South Padre Island to enact regulations addressing substandard buildings, including provisions for vacation, securing, abatement, repair, and demolition, and providing a means for notice and a public hearing for interested parties; and

WHEREAS, substandard buildings in the City of South Padre Island reduce the value of surrounding properties, often constitute health and safety hazards, and overall diminish the quality of life on South Padre Island; and

WHEREAS, the City Council desires to amend the substandard structure regulations currently found within the City Code to more clearly define and effectively address these issues; and

WHEREAS, the City Council finds that amending the code pursuant to Chapter 214 of the Texas Local Government Code as provided herein is in the best interests of and promotes the health, safety, and general welfare of its citizens in that it provides a means of abating, remedying, or otherwise resolving the problems created by substandard buildings;

NOW, THEREFORE, BE IT ORDAINED BY THE CITY COUNCIL OF THE CITY OF SOUTH PADRE ISLAND, TEXAS:

SECTION 1: That the current Chapter 4, Sections 4-17 and 4-18 of the City of South Padre Island Code of Ordinances be repealed and replaced with the following:

Sec. 4-17. – Substandard Structures

(A) Definitions.

As used in this article the following terms shall have the meanings given below:

Alterations means any change, addition, or modification in construction; any change in the structural members of a building, such as walls or partitions, columns, beams or girders; and may be referred to as "altered" or "reconstructed."

Approved means having the approval of the Code Official as the result of an investigation and tests that the Code Official conducted or by reason of accepted principles or tests by national authorities, technical, or scientific organizations; or having the approval of the appropriate enforcement official of the city as being represented by the applicant in compliance with the standards and requirements of this code or ordinance of the city that applies specifically to the item in question; or other customary approvals reserved to the city by state law or city ordinance.

Building means any structure, either temporary or permanent, having a roof or other covering, that is designed or used for the shelter or enclosure of any person, animal, or property of any kind, including tents, awnings, or vehicles situated on private property and used for purposes of a building.

Building official shall refer to the building official, or the building inspector designated to issue permits and inspect buildings or construction including permits and inspections related to the enforcement of this chapter.

City means the City of South Padre Island.

Code official means the official who is charged with the administration and enforcement of this Chapter, or any duly authorized representative.

Commercial building means any building or structure that is used or designed to be used, in whole or in part, for retail or wholesale business, industrial, manufacturing, storage, religious, educational, amusement, entertainment, health, professional, scientific, office, or other business purposes. "Commercial buildings" are a type of nonresidential building.

Construction means any clearing of land, excavation, or other action that would adversely affect the natural environment of the site. This definition does not include uses in securing survey or geological data such as necessary borings to ascertain subsurface conditions.

Dwelling means the entirety or any portion of any building that is not an "apartment house," or "lodging house," and that contains one or more "dwelling units" or "guest rooms" that are used, intended, or designed to be built, used, rented, leased, let, or hired out to be occupied, or which are occupied for living purposes.

Dwelling unit means a single unit providing complete, independent living facilities for one or more persons including permanent provisions for living, sleeping, eating, cooking, and sanitation.

Erected means built, constructed, altered, reconstructed, poured, laid, moved upon, excavated, site cleared, land filled, or any physical operations on the premises that are required for construction.

Nuisance means any of the following conditions:

- (1) Any condition of real property, building or other structure that fails to meet the minimum standards set forth in the International Codes or other Codes as adopted by the city and any local amendments made thereto.
- (2) Any attractive nuisance that may prove detrimental to children whether in a building; or attached to or grounded from the premises of a building; or upon, attached to or grounded from an unoccupied lot. This includes, but is not limited to, any abandoned wells, shafts, cellars, basements, excavations, abandoned

refrigerators, abandoned, junked or inoperative boats, houseboats, motor vehicles or motor vehicle parts, broken down or dilapidated docks, or lumber, trash, fences, debris or vegetation that may prove a hazard for inquisitive minors.

- (3) Whatever condition is dangerous to human life or is detrimental to health or property.
- (4) Overcrowding or occupancy in violation of this chapter.
- (5) Insufficient ventilation or illumination.
- (6) Inadequate or unsanitary sewerage or plumbing facilities.
- (7) Uncleanliness.
- (8) Whatever renders air, food, or drink unwholesome or detrimental to the health of human beings or animals.
- (9) Divergence of run-off to other private or public property.
- (10) The inability of a structure to obtain or maintain a certificate of occupancy due to its dilapidated status.

Occupant means any person who rents, leases or appears to reside, rent or lease a building, structure or property through custody of the premises or who has the legal right to possession of such premises.

Permit means a written document or certification issued by the building official permitting the specific construction, alteration, or extension requiring a permit under the provisions of this chapter, the technical codes and regulations stated herein.

Person shall mean and include an individual human, partnership, co-partnership firm, company, limited liability partnership or other partnership or other such company, joint venture, joint stock company, trust, estate, governmental entity, association or corporation or any other legal entity, or their legal representatives, agents or assigns. The masculine gender shall include the feminine, the singular shall include the plural where indicated by the context.

Repair means the reconstruction, renovation, or renewal of any part of an existing building for the purpose of its maintenance. This term shall not apply to any change or construction, alteration, or additions to a building other than for the purpose of reconstruction, renovation, or renewal.

Responsible parties or responsible party means the owner or occupant, including the person in custody of the building, property or structure and any mortgagee or lien holder.

Shall is a mandatory term.

Substandard structure means any structure or building located within the incorporated limits of the City that fails to comply with the general requirements for exterior structures, interior structures, or component serviceability as established by the International Codes or other Codes as defined below and by Section 4-5 of this Chapter, rendering it dangerous, unsafe, or unfit for human habitation or causing it to be in a state of disrepair or dilapidation so as to constitute a blighted area or property.

Substandard Structures Review Board or Board means the City Council of the City of South Padre Island, Texas.

(B) Substandard Structures.

(1) The requirements established by the most recent edition of the International Property Maintenance Code, the 2015 International Building Code, the 2015 International Residential Code without Section R313 (deleted), the 2015 International Fire Code without Appendices L and M (deleted), the 2015 International Mechanical Code, the 2015 International Plumbing Code, the 2015 International Fuel Gas Code, the 2014 National Electrical Code, the 2015 International Energy Conservation Code, the 1997 Standard Housing Code, and the 1985 Unsafe Building Abatement Code and all other amendments thereto except as modified by the Code of Ordinances, currently adopted and locally amended by the city are hereby declared to the minimum standards for the continued use and occupancy of all buildings located within the corporate limits of the city regardless of the date of their construction.

(2) A building or structure shall be deemed a Substandard Structure if:

(a) Said building or structure fails to comply with any one or more of the requirements established by the International Codes or other Codes cited above by Section 4-17(b)(1) and any local amendments made thereto;

(b) Said building or structure, regardless of its structural condition, is either unoccupied by its owners, lessees, or other invitees, or fails to meet the requirements for and does not currently hold a certificate of occupancy, and is:

(i) Unsecured from unauthorized entry to the extent that it could be entered or used by vagrants or other uninvited persons as a place of harborage or could be entered or used by children;

(ii) Boarded up; fenced, or otherwise secured in any manner if the building or structure constitutes a danger to the public even though secured from entry; or the means used to secure the building or structure are inadequate to prevent unauthorized entry or use of the building; or

(iii) Remains a new but incomplete or unfinished construction for an period of time which is unreasonable under the circumstances.

(C) Public nuisances declared.

(1) A building or structure deemed to be a Substandard Structure under the terms of this chapter is hereby declared to be a public nuisance and is unlawful.

(2) It shall be the responsibility of the owner[s] or occupants of Substandard Structure to abate public nuisances associated with said building by means of repair, rehabilitation, demolition, or removal in accordance with the procedures provided in this chapter.

(D) Duties of the code official.

The code official is authorized to inspect, or cause to be inspected, every building, or portion thereof, reported to be a Substandard Structure. If such building, or any portion thereof, is determined to be unsafe, the code official shall give the responsible parties notice in accordance with the requirements set forth in this article. If the code official is denied permission to inspect any building or portion thereof reported to be unsafe, the code official may employ or seek any legal assistance, including warrants, necessary to secure the ability to inspect for compliance with this chapter. The code official shall further:

- (1) Inspect or cause to be inspected, when necessary, any building or structure within the incorporated limits of the city, including public buildings, schools, halls, churches, theaters, hotels, tenements, or apartments, multifamily residences, single-family residences, garages, warehouses, and other commercial and industrial structures of any nature whatsoever for the purpose of determining whether any conditions exist which render such places a Substandard Structure as defined herein.
 - (2) Inspect any building, wall or structure about which complaints have been filed by any person to the effect that a building, wall or structure is or may be existing in violation of this article.
 - (3) Report to the Substandard Structures Review Board any noncompliance with the minimum standards set forth in this article. The code official shall obtain from the secretary of the Board a hearing date at the earliest opportunity possible for a public hearing by the Board on any building or structure believed to be a substandard structure and shall provide the secretary of the Board with copies of the written notice to persons with interests in the property.
 - (4) Appear at all hearings conducted by the Board and testify as to the conditions of substandard structures within the city.
 - (5) Place a notice on any substandard structure found to be out of compliance with the general requirements of the International Property Maintenance Code
 - (6) Make a diligent effort to identify each owner, mortgagee or lienholder, and their respective addresses, by searching the following: the real property records of the county; the tax appraisal district records; the records of the secretary of state; the assumed name records of the county; the tax records of Cameron County; and the utility records of record.
 - (7) Perform the other requirements with respect to notification of public hearings as are set forth more specifically in this article.
- (E) Notice to comply.
- (1) Should the code official determine that any building or structure within the incorporated limits of the city is a Substandard Structure, the official shall cause written notification to be sent, by certified mail, to each owner, mortgagee, and lienholder identified through a diligent effort to discover such owner, mortgagee, and lienholder. Such notice shall:
 - (a) Contain a description of the Substandard Structure and its location;

- (b) Contain a statement of the specific conditions which make the building or structure a Substandard Structure;
 - (c) Contain a statement that it shall be illegal to occupy or utilize said building for any purpose until such time as the premises have been brought into compliance with the applicable provisions of the International Property Maintenance Code.
 - (d) Include notice of the date and time of a public hearing before the Substandard Structures Review Board to determine whether the building complies with the standards set out in this article;
 - (e) Include a statement that the owner, lienholder, or mortgagee will be required to submit at the hearing, proof of the scope of any work that may be required to comply with this article and the amount of time it will take to reasonably perform the work; and
 - (f) Be served upon the responsible parties as set out in this article.
- (2) *Sufficiency of notice.* Notwithstanding any other term or provision of this article or the code, notice given pursuant to this article shall be sufficient and deemed properly served upon the responsible parties if a copy thereof is:
- (a) Served upon him/her personally; or
 - (b) Sent by registered or certified mail, return receipt requested, to the last known address of such person as shown on the records of the city and the tax appraisal district; and posted in a conspicuous place in or about the building affected by the notice.
- (3) *Compliance with notice.* The parties responsible for the Substandard Structure, shall have until the date and time of the hearing as described by Section 4-18 from the date of service of the notice to Substandard Structure into compliance with the provisions of this Chapter.
- (4) *Further occupancy prohibited.* Once a building is determined to be a Substandard Structure, the code official shall affix a placard on or near the front door of said building. The placard shall note the date of posting, provide the name and signature of the city official who determined the building to be a Substandard Structure, provide an identification, that is not required to be a legal description, of the building and the property on which it is located, and shall state the following:

THIS BUILDING HAS BEEN FOUND TO BE A SUBSTANDARD STRUCTURE UNDER THE TERMS OF THE (INSERT NAME OF CODE) CODE. OCCUPANCY OR USE OF THIS BUILDING BY ANY PERSON OR FOR ANY PURPOSE IS HEREBY PROHIBITED UNTIL SUCH TIME AS THE PREMISES HAVE BEEN BROUGHT INTO COMPLIANCE WITH THE APPLICABLE PROVISIONS OF THE (INSERT NAME OF CODE) CODE AND THIS PLACARD REMOVED BY THE CODE OFFICIAL. REMOVAL OF THIS PLACARD BY ANY PERSON OTHER THAN THE UNDERSIGNED OFFICER OF THE CITY SHALL BE UNLAWFUL.

7-21

- (5) *Refused or unclaimed mail.* All mailed notices shall be deemed sufficient and delivered if returned "refused" or "unclaimed."
 - (6) Notices sent pursuant to this article shall be sent to the address of the owner, lienholder, or mortgagee in the building as determined by a reasonable search of records to include:
 - (a) County real property records;
 - (b) Appraisal district records;
 - (c) Records of the Secretary of State, if the property owner or lienholder is a corporation, partnership, or other business association;
 - (d) Assumed name records;
 - (e) Tax records, and utility records of the city.
- (F) Additional authority to secure Substandard Structure.
- (1) In addition to the powers prescribed by this Chapter, the City may secure a Substandard Structure the municipality determines violates the standards as set out by this Chapter, provides an imminent threat of harm or danger to the public, and is unoccupied or is occupied only by persons who do not have a right of possession to the Structure.
 - (2) Before the 11th day after the date the Structure is secured, the municipality shall give notice to the owner by:
 - (a) Personally serving the owner with written notice;
 - (b) Depositing the notice in the United States mail addressed to the owner at the owner's post office address;
 - (c) Publishing the notice at least twice within a 10-day period in a newspaper of general circulation in the county in which the building is located if personal service cannot be obtained and the owner's post office address is unknown; or
 - (d) Posting the notice on or near the front door of the Structure if personal service cannot be obtained and the owner's post office address is unknown.
 - (3) The notice must contain:
 - (a) An identification, which is not required to be a legal description, of the Structure and the property on which it is located;
 - (b) A description of the violation of the municipal standards that is present at the Structure;
 - (c) A statement that the municipality will secure or has secured, as the case may be, the Structure; and

- (d) An explanation of the owner's entitlement to request a hearing about any matter relating to the municipality's securing of the Structure. The explanation must notify the owner that the owner must file with the city a written request for such hearing within 30 days of the city securing the Structure.
 - (i) A hearing requested pursuant to this section shall be undertaken by the Substandard Structures Review Board no later than 20 days after the date the request is filed.
- (4) The city has the same authority to assess expenses under this section as it has to assess expenses under Section 4-18 (12). A lien is created under this section in the same manner that a lien is created under Section 4-18 (12) and is subject to the same conditions as a lien created under that section.

Sec. 4-18. – Substandard Structures Review Board

- (1) In order to conduct public hearings and to hear and decide appeals of orders, decisions or determinations made by the code official or building official relative to the application and interpretation of this article, the city council shall serve as the Substandard Structures Review Board to pass upon matters pertaining to building standards. The Substandard Structures Review Board may adopt rules of procedure for conducting its business and shall render all decisions and findings in writing to the property owner and lien holders, with a duplicate copy to the code official. Appeals to the board shall be processed in accordance with the provisions established by this article.
- (2) Duties of the Substandard Structures Review Board.
 - (a) The Substandard Structures Review Board shall:
 - (i) Schedule and hold a public hearing and hear testimony from the code official, and the owner, mortgagee, or lienholder of the substandard structure. Such testimony shall relate to the determination of the question of whether the building or structure in question is a Substandard Structure and the scope of any work that may be required to comply with this article and the amount of time it will take to reasonably perform the work. The owner, mortgagee, and/or lienholder shall have the burden of proof to demonstrate the scope of any work that may be required to comply with this article and the time it will take to reasonably perform the work.
 - (ii) Upon conclusion of the hearing, the Substandard Structures Review Board shall determine by majority vote of its Board membership whether the building or structure in question is a substandard structure. Upon a determination that the building or structure in question constitutes substandard and out of conformance with the requirements of this Chapter, the Substandard Structures Review Board shall issue an order:

- A. Containing an identification of the building and the property on which it is located;
 - B. Making written findings of the violations of the minimum standards that are present at the building;
 - C. Requiring the owner, mortgagee, or lienholder to repair, vacate, or demolish the building within 30 days from the issuance of such order, unless the owner or a person with an interest in the building establishes at the hearing that the work cannot reasonably be performed within 30 days, in which instance the Substandard Structures Review Board shall specify a reasonable time for the completion of the work; and
 - D. Containing a statement that the city will vacate, secure, repair or demolish the Substandard Structure and relocate the occupants of the structure if the ordered action is not taken within the time specified by the Board.
- (3) The code official or city secretary shall deliver a copy of said order by hand delivery or certified mail to the owner and all persons having an interest in the property, as such persons appear in the official records described herein, including all identifiable mortgagees and lienholders, as soon as is practicable after the hearing, which order shall include an identification and address of the building and the property on which it is located; a description of the violation of this article that are found to be present at the building; and a statement that the municipality will vacate, secure, remove, repair, or demolish the building and relocate the occupants of the building if the ordered action is not taken within the agreed-upon reasonable time.
 - (4) If the Substandard Structures Review Board allows the owner, mortgagee, or lienholder of the Substandard Structure more than 30 days to repair, remove, or demolish the building, the Board in its written order shall establish specific time schedules for the commencement and performance of the work and shall require the owner or person to secure the property in a reasonable manner from unauthorized entry while the work is being performed. The securing of the property shall be in a manner found to be acceptable by the Code official.
 - (5) The Substandard Structures Review Board shall not allow the owner, mortgagee, or lienholder of the Substandard Structure more than 90 days to repair, remove, or demolish the building or fully perform all work required to comply with the written order unless the owner or person:
 - (a) Submits a detailed plan and time schedule for the work at the hearing; and
 - (b) Establishes at the hearing that the work cannot reasonably be completed within 90 days because of the scope and complexity of the work.
 - (6) If the value of a property subject to a Substandard Structures Review Board order exceeds \$100,000.00, the board, at its election, may require the owner, lienholder, or mortgagee to post a cash or surety bond in an amount adequate to cover the

cost of repairing, removing, or demolishing a building. In lieu of a bond, the board may require the owner, lienholder, or mortgagee to provide a letter of credit from a financial institution or a guaranty from a third party approved by the city. If required by the board, the bond must be posted, or the letter of credit or third party guaranty provided not later than the 30th day after the date the Board issues its order.

- (7) If the Substandard Structures Review Board allows the owner, mortgagee, or lienholder of the Substandard Structure more than 90 days to complete any part of the work required to repair, remove, or demolish the building, the Board shall require them to regularly submit progress reports to the Board to demonstrate that the owner or person has complied with the time schedules established for commencement and performance of the work. The written order may require that they appear before the code official to demonstrate compliance with the time schedules.
- (8) Appeals. In the event the owner fails to appeal an order issued by the Substandard Structures Review Board under this article within 30 days of the date said order was personally delivered to them, mailed to them by first class mail with certified return receipt requested, or delivered to them by United States Postal Service using signature confirmation service, the order shall become final and unappealable. In the event an owner fails to comply with the order within the time frame specified therein, following the expiration of 30 days from the date the order was personally delivered to them, mailed to them by first class mail with certified return receipt requested, or delivered to them by United States Postal Service using signature confirmation service, the city will be authorized to take action to abate the public nuisance and affix a lien against the property.
- (9) After the public hearing, if a building is found in violation of the minimum requirements of this article, the Substandard Structures Review Board may order that the occupants be relocated within a reasonable time.
- (10) In addition to the authority granted to the Substandard Structures Review Board under this chapter, the city may also pursue any and all other remedies provided by state law including filing suit in the appropriate court of competent jurisdiction to enforce this article.
- (11) If the building is not vacated, secured, repaired, removed, or demolished, or the occupants are not relocated within the allotted time, the city may vacate, secure, remove, repair or demolish the building or relocate the occupants at its own expense after the timeframe for appealing the Board's order pursuant to subsection (8) has expired.
- (12) If the city incurs expenses as a result of enforcing the provisions of this article, said expenses may be assessed against the property in the form of a lien unless it is a homestead as protected by the Texas Constitution. The lien is extinguished if the property owner or another person having an interest in the legal title to the property reimburses the city for the expenses. The lien arises and attaches to the property at the time of the notice of the lien is recorded and indexed in the office

of the county clerk. The notice must contain in the name and address of the owner if that information can be determined by a reasonable effort, a legal description of the real property on which the building was located, the amount of expenses incurred by the city, and the balance due. A lien filed in accordance with the terms of this article is a privileged lien subordinate only to tax liens and all previously recorded bona fide mortgage liens attached to the real property to which the city's lien attaches.

(13) Notice. If repair or demolition is ordered, the Substandard Structures Review Board shall send a copy of the order by certified mail to the owner and all persons having an interest in the property, including all identifiable mortgagees and lienholders within ten days after the hearing. Within ten days after the date that the order is issued, the city shall:

- (a) File a copy of the order in the office of the municipal secretary or clerk; and
- (b) Publish in a newspaper of general circulation in the municipality in which the building is located a notice containing:
 - (i) The street address or legal description of the property;
 - (ii) The date of the hearing;
 - (iii) A brief statement indicating the results of the order (may be a copy of the order); and
 - (iv) If not provided in the notice, instructions stating where a complete copy of the order may be obtained.
- (c) If repair or demolition is ordered and notice of public hearing was not filed in the official public records of real property of the county, the city may file and record a copy of the order in such records of the county.

(14) Secure property. If the Substandard Structures Review Board allows the owner of the Substandard Structure more than 30 days to repair, remove, or demolish the building, the Board in its written order shall establish specific time schedules for the commencement and performance of the work and shall require the owner or person to secure the property in a reasonable manner from unauthorized entry while the work is being performed. The securing of the property shall be in a manner found to be acceptable by the code official.

(G) Assessment of expenses and penalties.

(1) In addition to the authority granted under Chapter 214 of the Texas Local Government Code and this Chapter, the city may:

- (a) Order the repair of the building at the city's expense and assess the expenses on the land on which the building stands or to which it is attached, or

7-26

- (b) Assess a civil penalty against the responsible party for failure to repair, remove, or demolish the building.
 - (2) The city, at its election, may use city resources or contract with appropriate service providers to demolish a building that is subject to a Substandard Structures Review Board demolition order. Should the city choose to retain an outside demolition contractor, the code official shall invite at least two or more building contractors to make estimates pertaining to the needed repair, removal or demolition of a building. The code official shall cause to be made an assessment of expenses or civil penalty based on such estimates. The code official shall endeavor to minimize the expenses of any building repairs, removal or demolitions order pursuant to this subchapter.
 - (3) The city may repair a building subject to a Substandard Structures Review Board order only to the extent necessary to bring the building into compliance with the general requirements of the International Property Maintenance Code and only if the building is a residential building with ten or fewer dwelling units. The repairs may not improve the building to the extent that the building exceeds minimum standards prescribed by the code.
 - (4) The city's lien to secure the payment of a civil penalty or the costs of repairs, removal, or demolition is inferior to any previously recorded bona fide mortgage lien attached to the real property to which the city's lien attaches if the mortgage lien was filed for record in the office of the county clerk before the date the civil penalty is assessed or the repair, removal, or demolition is begun by the city. The city's lien is superior to all other previously recorded judgment liens.
 - (5) Any civil penalty or other assessment imposed under this section accrues interest at the rate of ten percent a year from the date of assessment until paid in full.
 - (6) A lien acquired under this section by the city for repair expenses may not be foreclosed if the property on which the repairs were made is occupied as a residential homestead.
- (H) Violations.
- (1) The owner of any Substandard Structure who shall fail to comply with any notice or order to repair, vacate or demolish said building or structure, such notice or order given by the authority of the Substandard Structures Review Board, shall be guilty of a misdemeanor.
 - (2) An occupant, or lessee in possession of any Substandard Structure who fails to comply with any notice or order to vacate such building and fails to repair such building in accordance with an order given by the Substandard Structures Review Board shall be guilty of a misdemeanor.
 - (3) Any person removing the notice of a Substandard Structure as provided for by this article, shall be guilty of a misdemeanor.
 - (4) The violation of any provision of this article shall be unlawful and a misdemeanor offense punishable by a fine not exceeding \$500.00. Each day a violation of this article continues shall constitute a separate offense.

- (5) In any prosecution charging a violation of this article governing the failure to comply with any notice or order to repair, vacate, remove, or demolish any building or structure, proof that the particular property described in the complaint was substandard in violation of this article, together with proof that the defendant named in the complaint was, at the time of such notice or order, the registered owner of such property, shall constitute in evidence a prima facie presumption that the registered owner of such property was the person who failed to comply with the notice or order to repair, vacate, remove, or demolish, and for the time during which, such violation occurred.

SECTION 2: This Ordinance repeals all portions of any prior ordinances or parts of ordinances of the Code of Ordinances in conflict herewith.

SECTION 3: If for any reason, any section, paragraph, subdivision, clause, phrase, word, or provision of the Ordinance shall be held unconstitutional by final judgment of a court of competent jurisdiction, it shall not affect any other section, paragraph, subdivision, clause, phrase, word, or provision of this Ordinance, for it is the definite intent of this City Council that every section, paragraph, subdivision, clause, phrase, word, or provision hereof be given full force and effect for its purpose.

SECTION 4: This Ordinance shall become effective when published in summary form according to law.

PASSED, APPROVED AND ADOPTED on First Reading, the 19th day of June 2019.

PASSED, APPROVED AND ADOPTED on Second Reading, the 17th day of July 2019.

ATTEST:

CITY OF SOUTH PADRE ISLAND,
TEXAS

Susan M. Manning, City Secretary

Patrick McNulty, Mayor

7-28

**CITY OF SOUTH PADRE ISLAND
CITY COUNCIL MEETING
AGENDA REQUEST FORM**

MEETING DATE: July 17, 2019

NAME & TITLE: Mickey Furcron, President

DEPARTMENT: Economic Development Corporation

ITEM

Discussion and action to approve the South Padre Island Economic Development Corporation's (EDC) annual budget for fiscal year 2019/20.

ITEM BACKGROUND

The EDC held several budget workshops including one with the Birding and Nature Center Board. The budget attached was approved by the EDC Board on June 17, 2019 and was the result of these workshops. The Bylaws of the EDC state the City Council approves the annual budget.

BUDGET/FINANCIAL SUMMARY

The 2019/20 budget presented will be what the EDC will work from during the next fiscal year.

COMPREHENSIVE PLAN GOAL

LEGAL REVIEW

Sent to Legal: YES: _____ NO: _____
Approved by Legal: YES: _____ NO: _____

RECOMMENDATIONS/COMMENTS

The EDC Board seeks City Council approval of the budget.

EDC Fund - Budget for Fiscal Year 2019-20 (APPROVED BY EDC 6/17/19)

	Budget Approved for 2018-19	current year estimate	Increase/Decrease	Budget Proposed for 2019-20	Notes
<u>REVENUE</u>					
Sales tax	\$ 813,000	\$ 852,000	\$ 37,000	\$ 850,000	
Operating Bank Interest	-	9,000	4,000	4,000	Interest from IBC Operating Account
Revolving Loan Revenue(Principal)	11,581	11,581	472	12,053	BNC Loan - Principal
Interest Revenue (BNC Loan)	1,194	1,194	(472)	722	BNC Loan - Interest
BNC Building Rental	10	10	11,990	12,000	Annual rent based on 12.5 cents/sq ft, 8000 sq ft
Total Revenue	825,785	873,785	52,990	878,775	
<u>EXPENSES</u>					
<u>ADMINISTRATIVE - EDC</u>					
Salary	\$ 60,770		\$ 5,230	\$ 66,000	
Medicare	1,142		99	1,241	
Group insurance	7,328		107	7,435	
Retirement	8,137		476	8,613	
Workers compensation	164		(19)	145	
Unemployment Tax	142		(110)	32	
Temp Help-Summer Intern	3,000		(3,000)	-	
TOTAL ADMINISTRATIVE- EDC	80,683		2,783	\$ 83,466	
<u>OPERATING - EDC</u>					
Office supplies	900	700		900	office supplies and minor eqpt.
Local meetings	700	700		700	Business lunches, meeting supplies
Books, publications	400	200	(200)	200	Demographic Reports, PI Press
Postage	100	100		100	Stamps, Shipping Charges (UPS, FedEx)
Information Technology	1,000	800	(200)	800	IT equipment, grant software
Communication	800	-	(200)	600	Cell phone allowance
Training	1,500	1,500		1,500	TEDC, Seminars, Webinars, IEDC
Insurance	1,000	1,000		1,000	D&O Liability
Professional services					
Legal	1,500	1,500		1,500	City Attorney fees
Social Media	-	-	600	600	Posting on Social media
Web	3,000	3,000		3,000	Annual fees for Website and software
Continuing Disclosure(Bond)	4,000	4,000		4,000	Estrada Hinojosa Bond Counselor annual contract
Bank Fees	-	1,200	1,200	1,200	Fees on IBC Operating Account
Audit	3,000	3,000		3,000	Reimburse City for Audit
Muni Services Reports	-	3,000	3,000	3,000	Sales Tax Reports
Total Professional Svcs.	11,500			16,300	Total of Lines 33-38

2-8

	Budget Approved for 2018-2019	current year estimate	Increase/Decrease	Budget Proposed for 2019-2020	Notes
Advertising	3,500	4,500	1,000	4,500	Chamber, Classifieds, RGV Partnership
Travel	6,000	6,000		6,000	IEDC, TEDC, Sales tax training, Mileage
Promotions	3,000	3,000		3,000	Marketing, Sponsorships
Dues & Memberships	1,000	1,000		1,000	TEDC, RGV Partnership, Texas Downtown Assoc
<u>TOTAL OPERATING- EDC</u>	\$ 31,400		4,000	\$ 36,600	
<u>BIRDING CENTER -EXPENSES</u>					
Insurance	\$ 45,000	\$ 45,000		\$ 45,000	Windstorm, Flood, Liability
Transfer to Facility Maint Fund	67,600		2,704	70,304	Facility Reserves Study amount
Building Maintenance-Preventative	-		5,000	5,000	Elevator Maintenance contract
Cash Advances	10,000		(10,000)	-	BNC Revenue shortfalls
<u>BIRDING CENTER EXPENSES</u>	\$ 122,600	\$ 45,000	\$ (2,296)	\$ 120,304	
TRANSFER TO DEBT SERVICE	390,650	390,650	3,800	394,450	Bond payment for BNC facility
<u>TOTAL ADMIN., OPER., & TFRS</u>	625,333		9,487	634,820	
<u>PROJECTS</u>					
Lobbyist	25,000		(25,000)	-	
Economic Consulting	4,000		-	4,000	Dr. Malki Resort Market Analysis update
Business Development	60,000		-	60,000	Kauffman Entrepreneur, SandDollars for Success
Website Rebuild			18,000	18,000	New EDC website
Artificial Reef			25,000	25,000	Friends of RGV Reef project
Art Business Incubator			40,000	40,000	Art Business Incubator
Façade Improvement Program	25,000		-	25,000	Façade Improvement Grants
Designated projects (all other)	86,452			71,935	Other projects
<u>TOTAL PROJECTS</u>	200,452		43,483	243,935	
<u>TOTAL EXPENSES</u>	\$ 825,785	\$ -	\$ 52,970	\$ 878,755	

83

Facility Maintenance Fund - Budget for Fiscal Year 2019-20 DRAFT

	Budget Approved for 2018-19	current year estimate	Increase/Decrease	Budget Proposed for 2019-20
<u>REVENUE</u>				
Transfer from EDC Fund	\$ 67,600	\$ -	\$ 2,704	\$ 70,304
Total Revenue	67,600	-	2,704	70,304
<u>EXPENSES</u>				
Reserve Study Expenditures	\$ 67,600		\$ (1,635)	\$ 65,965
Total Expenditures	67,600	-	(1,635)	65,965

h-8

**CITY OF SOUTH PADRE ISLAND
CITY COUNCIL MEETING
AGENDA REQUEST FORM**

MEETING DATE: July 17, 2019

NAME & TITLE: Joe Ricco/Kerry Schwartz, Council Members

DEPARTMENT: City Council

ITEM

Discussion and action to prohibit sound devices that emit noise, such as blue tooth, stereo systems on commercial/rental golf carts within the city limits.

ITEM BACKGROUND

In an effort to curtail the noise nuisance caused by commercial golf cart rentals, we are proposing to prohibit sound devices that emit noise on all commercial golf carts which would include, but not limited to, stereo systems, blue tooth, boom boxes, and speakers. This does not include noise emitted from the vehicle's horn or golf carts that are permitted for personal use by private citizens.

BUDGET/FINANCIAL SUMMARY

COMPREHENSIVE PLAN GOAL

LEGAL REVIEW

Sent to Legal: YES: _____ NO: X
Approved by Legal: YES: _____ NO: X

RECOMMENDATIONS/COMMENTS

ORDINANCE NO. 19-04

AN ORDINANCE OF THE CITY OF SOUTH PADRE ISLAND, TEXAS AMENDING CHAPTER 18, TRAFFIC, SECTION 18-30, GOLF CARTS TO INCLUDE ADDED LANGUAGE IN SECTION 18-30(D)(8) TO DETERMIN AND CONTROL THE ACCEPTABLE LEVEL OF NOISE THAT IS EMITTED FROM GOLF CARTS; PROVIDING FOR PENALTY FOR VIOLATION; PROVIDING FOR CUMULATIVE AND CONFLICTS AND SEVERABILITY CLAUSES; AND PROVIDING FOR AN EFFECTIVE DATE.

WHEREAS, the streets and other public roadways within the City, the Act entitled "Uniform Act Regulating Traffic on Highways" contained in Article 6701d, V.A.C.S. and the rules for safe driving issued by the State Department of Public Safety, shall be in full force and effect in the City; and

WHEREAS, the use of motorized carts, commonly referred to as golf carts, is permitted for the enjoyment of its residents and visitors in the city limits of South Padre Island; and

WHEREAS, the City Council is tasked with finding ways to reduce the noise level emitted from golf carts to an acceptable level, and

WHEREAS, the City Council finds that the provisions of this ordinance ae in the interest of the health, safety and welfare of the City.

NOW THEREFORE BE IT ORDAINED BY THE CITY COUNCIL OF SOUTH PADRE ISLAND, TEXAS.

Section one. Chapter 18 Section 18-30(D) "Operation Regulations" is amended to include added language in Section 18-30(D)

Section two. Chapter 18 Section 18-30(D)(8) is hereby added to determine and control the acceptable level of noise that is emitted from golf carts during all operations. The highest decibel reading during night time hours accepted in the residential districts is 68 decibels at a distance of thirty feet from the golf cart. Sixty eight (68) decibels will be the highest level of noise permitted from golf cards during operation at all time and any location.

Section three. Penalty. Violation of this ordinance shall be a Class C misdemeanor and upon conviction for such violation, the defendant shall be subject to a fine not less than \$1.00 and not more than \$500.00.

Section four. Cumulative and Conflicts. This Ordinance shall be cumulative of all provisions of ordinances of the City of South Padre Island, Texas, except where the provisions of the Ordinance are in direct conflict with the provisions of such ordinances, in which event the

conflicting provisions of such ordinances are hereby repealed. Any and all previous versions of this Ordinance to the extent that they are in conflict herewith are repealed.

Section five. Severability. It is hereby declared to be the intention of the City Council that the phrases, clauses, sentences, paragraphs, and sections of this Ordinance are severable, and if any phrase, clause, sentence, paragraph or section of this Ordinance shall be declared unconstitutional by the valid judgment or decree of any court of competent jurisdiction, such unconstitutionality shall not affect any of the remaining phrases, clauses, sentences, paragraphs and sections of this Ordinance, since the same would have been enacted by the City Council without the incorporation in this Ordinance of any such unconstitutional phrase, clause, sentence, paragraph or section.

Section six. Publication. The City Secretary is authorized and directed to publish a caption of this ordinance.

Section seven. Effective Date. This Ordinance shall become effective immediately upon its passage, approval, and publication as provided by law.

PASSED AND APPROVED ON FIRST READING THIS THE 20th DAY OF February 2019.

PASSED AND APPROVED ON SECOND READING THIS THE 6th DAY OF March 2019.

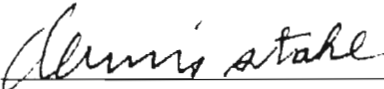

Dennis Stahl, Mayor

ATTEST:



Susan Hill, City Secretary



ORDINANCE NO. 10-24

AN ORDINANCE OF THE CITY OF SOUTH PADRE ISLAND, TEXAS, AMENDING CHAPTER 18 OF THE CODE OF ORDINANCES OF THE CITY OF SOUTH PADRE ISLAND BY ADDING A NEW SECTION 18-30 TO PROVIDE FOR PERMITTING AND REGULATING MOTORIZED CARTS AND GOLF CARTS, PROVIDING FOR DEFINITIONS, REQUIRED EQUIPMENT, RESTRICTIONS ON STREETS THAT IT MAY USE, REQUIRED PERMIT AND FEES; PROVIDING FOR SEVERABILITY AND REPEAL OF CONFLICTING ORDINANCES; PROVIDING A PENALTY NOT TO EXCEED FIVE HUNDRED DOLLARS (\$500.00) FOR EACH VIOLATION; PROVIDING FOR THE EFFECTIVE DATE OF THE ORDINANCE; AND PROVIDING FOR PUBLICATION IN CAPTION FORM.

NOW, THEREFORE, BE IT ORDAINED BY THE CITY COUNCIL OF THE CITY OF SOUTH PADRE ISLAND, TEXAS:

Section 1. The Code of Ordinances of the City of South Padre Island is hereby amended to add a new Section 18-30 to Chapter 18 to read as follows, to-wit:

“Sec. 18-30. GOLF CARTS.

(A) The following words, terms and phrases when used in this Section, shall have the meanings ascribed to them in this Section except where the context clearly indicates a different meaning:

Driver: means the person driving and having physical control over the motorized cart.

Motorized cart: means those electric and gasoline powered carts, commonly referred to as golf carts, but which must have a minimum of four (4) wheels and which have an attainable top speed not greater than twenty-five (25) miles per hour on a paved level surface and which is manufactured in compliance with those federal motor vehicle safety standards for low-speed vehicles. Specifically excluded from this definition are those motorized conveyances commonly referred to as ATVs, four-wheelers, mules, and gators.

Owner: means the person holding title to the motorized cart.

Parking area: means those areas accessible to the public by motor vehicular traffic and which are designated for temporary parking of motor vehicles, usually in places referred to as parking lots.

Street: means the public roadways of the City of South Padre Island by whatever name (e.g., road, alley, avenue, highway, route, boulevard, etc.) that:

- (1) Has a posted speed limit of thirty-five (35) miles per hour or less; or
- (2) Provides for no more than two (2) lanes of vehicular traffic per direction.

(B) Electric and gasoline motorized cart required equipment.

Every motorized cart must be equipped as mandated by the Texas Transportation Code, Section 551.404(a) and/or required by the City of South Padre Island the following:

- (1) Operational headlamps;

9-4

- (2) Operational tail lamps;
- (3) Side reflectors;
- (4) Operational parking brake; and
- (5) Rearview mirror(s).
- (6) A reflective triangle shaped slow-moving sign attached and facing to the rear;
- (7) Owners of motorized cart must carry valid liability insurance for said cart in the minimum amount required by State law for the operators of a motor vehicle or the driver must carry proof that he/she has such liability insurance.
- (8) Driven during daylight hours only.
- (9) Be permitted thru the city and display a current (annual) sticker permit or license plate at the cost of \$50 per cart (annual fee) and a \$25 replacement fee.
- (10) Seatbelts for all passengers or occupants.

(C). Gasoline carts.

Every motorized cart powered by gasoline shall at all times be equipped with an exhaust system in good working order and in constant operation and meeting the following specifications:

- (1) The exhaust system shall include the piping leading from the flange of the exhaust manifold to and including the muffler and exhaust pipes or including any and all parts specified by the manufacturer.
- (2) The exhaust system and its elements shall be securely fastened with brackets or hangers, which are designed for the particular purpose of fastening motorized cart exhaust systems.
- (3) The engine and powered mechanism of every motorized cart shall be so equipped, adjusted and tuned so that the exhaust is the amount of a motorized cart in good working order.
- (4) It shall be unlawful for the owner of any motorized cart to operate or permit the operation of such cart on which any device controlling or abating atmospheric emissions which is placed on a cart by the manufacturer is rendered unserviceable by removal, alteration or which interferes with its operation.

(D) Operation regulations.

- (1) All drivers of motorized carts shall hold a valid Texas driver's license and shall abide by all traffic regulations applicable to vehicular traffic when using the authorized streets and parking areas of the city.
- (2) Motorized carts shall not be operated on sidewalks at any time.
- (3) All motorized carts are entitled to a full use of a lane on the authorized streets and parking areas of the city and no motor vehicle shall be driven in such a manner as to deprive any motorized cart of the full use of a lane.
- (4) The driver of a motorized cart shall not overtake and pass in the same lane occupied by the vehicle being overtaken.
- (5) No driver shall operate a motorized cart between lanes of traffic or between adjacent lines of rows of vehicles.
- (6) The occupancy of the motorized cart may not exceed the manufactures maximum rating for number of passengers or occupants.
- (7) Motorized carts may only be operated on streets that have a posted speed limit of thirty-five (35) miles per hour or less.

9-5

(E) Liability.

Nothing in this Section shall be construed as an assumption of liability by the City of South Padre Island for any injuries to persons, pets or property which may result from the operation of a motorized cart by an authorized driver.

Owners are fully liable and accountable for the actions of any individual that they provide permission to operate and drive said motorized cart, both on personal and/or city and public properties. This described liability responsibility especially applies to personal injuries or property damage resulting from motorized cart drivers who are minors under the age of twenty-one (21) with or without a current and valid Texas drivers license.

(F). Penalties.

Any person who violates the terms of this Section shall be penalized as provided by Sec. 21-1 of the Code of Ordinances.”

Section 2. Any violation of this Ordinance may be punished by a fine not to exceed Five Hundred Dollars (\$500.00) for each offense or for each day such offense shall continue and the penalty provisions of Section 21-1 of the Code of Ordinances is hereby adopted and incorporated for all purposes.

Section 3. If for any reason, any section, paragraph, subdivision, clause, phrase, word, or provision of this Ordinance shall be held invalid or unconstitutional by final judgment of a court of competent jurisdiction, it shall not affect any other section, paragraph, subdivision, clause, phrase, word, or provision of this Ordinance, for it is the definite intent of this City Council that every section, paragraph, subdivision, clause, phrase, word, or provision hereof be given full force and effect for its purpose.

Section 4. This Ordinance shall become effective when published in summary form or by publishing its caption.

PASSED, APPROVED AND ADOPTED on First Reading, this 16th day of June 2010.

PASSED, APPROVED AND ADOPTED on Second Reading, this 7th day of July 2010.

ATTEST:

CITY OF SOUTH PADRE
ISLAND, TEXAS



Susan Hill, CITY SECRETARY

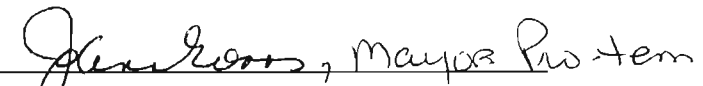

ROBERT N. PINKERTON, JR., MAYOR



9-6

**CITY OF SOUTH PADRE ISLAND
CITY COUNCIL MEETING
AGENDA REQUEST FORM**

MEETING DATE: July 17, 2019

NAME & TITLE: Joe Ricco/Kerry Schwartz, Council Members

DEPARTMENT: City Council

ITEM

Discussion and action to regulate and limit the number of motorized golf cart rental license plates issued for commercial rental.

ITEM BACKGROUND

We are proposing that the City regulate and limit the number of golf cart license plates issued for commercial rental use. The City currently has 491 golf cart license plates issued out. Of the 491 license plates, 327 are renewals while 164 have been newly issued. According to Police and Fire Department statistics, there have been 14 golf cart accidents this year which resulted in several injuries to the occupants of the vehicles.

BUDGET/FINANCIAL SUMMARY

COMPREHENSIVE PLAN GOAL

LEGAL REVIEW

Sent to Legal: YES: _____ NO: X
Approved by Legal: YES: _____ NO: X

RECOMMENDATIONS/COMMENTS



Motorized Golf Cart License Plate Application

City of South Padre Island
 4601 Padre Blvd.
 South Padre Island, TX 78597
 Phone: (956) 761-5454
 Fax: (956) 761-9544

Date Issued: _____ Date Expires: _____

I, the undersigned applicant for a golf cart license, swear or affirm that I have received a copy of the South Padre Island City Ordinance 18-30. I understand that the authority to operate a golf cart within the City of South Padre Island is a revocable privilege granted only upon compliance with the terms of the South Padre Island City Ordinance to legally operate a golf cart within the corporate boundaries of the City of South Padre Island, during the year when granted. I understand my failure to operate a golf cart in accordance with the City Ordinance may result in criminal and/or civil liability including fine, vehicle impoundment, and/or revocation of my license/privilege to operate a golf cart within the City of South Padre Island.

I understand that as the owner and/or operator of a golf cart that is operated within the City of South Padre Island that I have certain duties and obligations that are enumerated within the City Ordinances; specifically that said golf cart(s) is (are) outfitted with the following safety equipment and that all safety equipment is fully operational:

- Head Lamps - Tail Lamps - Reflectors - Seat Belts
- Parking Brakes - Rearview Mirror - Slow Moving Vehicle Emblem

I further understand that operation is only during daylight hours and to conform to City Ordinance 18-30 which provides that they be permitted by the City and display a current (annual) sticker permit or license plate.

I furthermore swear or affirm that said golf cart(s) are insured or bonded in accordance with Texas state laws governing minimum insurance/financial responsibility laws for motor vehicles.

In this application, I do swear or affirm that all the facts and statements contained herein are true and correct, and I understand that any falsification or misrepresentation may be subject to civil or criminal penalties and/or revocation of my golf cart license.

 Printed Name

 Signature

Owner Information	
Last Name:	_____
Middle Name:	_____
First Name:	_____
Driver's License #: (attach a copy of the DL)	_____

Contact Phone Numbers	
Home:	_____
Work:	_____
Cell:	_____

Vehicle Information	
License Plate #:	_____
VIN/Serial #:	_____
Make/Manufacturer:	_____
Model:	_____
Number of Seats:	_____
Color:	_____
Address where golf cart is housed: (number & street)	_____
Insurance: (attach a copy of the policy)	_____

Payment Method	
<input type="checkbox"/> Cash	
<input type="checkbox"/> Check # _____	

Fees	
<input type="checkbox"/> Annual Permit Fee	\$50.00
<input type="checkbox"/> Replacement Fee	\$25.00

Please submit to the Police Department.
 RGonzalez@MySPI.org

Form Number: EPO0001
 Last Updated: 06/21/11

10-2



South Padre Island Police Department

Randy Smith, Chief

Golf Cart Operation Regulations.

1. All drivers of motorized carts shall hold a valid driver's license and shall abide by all traffic regulations applicable to vehicular traffic when using the authorized streets and parking areas of the city. _____
2. Motorized carts shall not be operated on sidewalks at any time. _____
3. All motorized carts are entitled to a full use of a lane on the authorized streets and parking areas of the city and no motor vehicle shall be driven in such a manner as to deprive any motorized cart of the full use of a lane. _____
4. The driver of a motorized cart shall not overtake and pass in the same lane occupied by the vehicle being overtaken. _____
5. No driver shall operate a motorized cart between lanes of traffic or between adjacent lines of rows of vehicles. _____
6. The occupancy of the motorized cart may not exceed the manufacturer's maximum rating for number of passengers or occupants. _____
7. Motorized carts may only be operated on streets that have a posted speed limit of thirty-five (35) miles per hour or less. _____
8. A motor vehicle operator shall use a horn to provide audible warning only when necessary to insure safe operation. Texas Transportation Code Sec. 547.501 Audible Warning Devices. _____
9. The continued or frequent sounding of any horn or other signal device on any automobile or vehicle, motorcycle, bus or other vehicle, except as a danger signal is declared to be "noise nuisances," and is unlawful and in violation of City Ordinance Sec. 12-2 Noises—Loud, disturbing, etc. prohibited. _____
10. The highest decibel reading during night time hours accepted in the residential districts is 68 decibels at a distance of thirty feet from golf cart. Sixty-eight (68) decibels will be the highest level of noise permitted from golf carts during operation at all times and any location. _____

Sec. 21-1. - Penalty not to exceed five hundred dollars (\$500.00).

The violation of any such provision of any of said Chapter shall be punished by a fine not to exceed Five Hundred Dollars (\$500.00) for each offense.

Randy Smith
Chief of Police

City of South Padre Island -- Police Department -- Randy Smith, Chief

4601 Padre Boulevard • South Padre Island, Texas 78597 • 956.761.5454 • Fax 956.761.9544

10-3

GOLF CART INSPECTION SHEET

Owner: _____

Address: _____

Telephone # : _____

Golf Cart Color _____ Golf Cart Year/ Model: _____

Golf Cart VIN#: _____

Electric and gasoline motorized cart required equipment.

Every motorized cart must be equipped as mandated by the Texas Transportation Code, Section 551.404 (s) and/ or required by the City of South Padre Island the Following:

- | | | | | | |
|-----|--|-----|--------------------------|----|--------------------------|
| 1.) | Operational head lamps | Yes | <input type="checkbox"/> | No | <input type="checkbox"/> |
| 2.) | Operational tail lamps | Yes | <input type="checkbox"/> | No | <input type="checkbox"/> |
| 3.) | Side reflectors | Yes | <input type="checkbox"/> | No | <input type="checkbox"/> |
| 4.) | Operational parking brake | Yes | <input type="checkbox"/> | No | <input type="checkbox"/> |
| 5.) | Rearview Mirror | Yes | <input type="checkbox"/> | No | <input type="checkbox"/> |
| 6.) | Seat Belts | Yes | <input type="checkbox"/> | No | <input type="checkbox"/> |
| 7.) | A reflective triangle shaped slow-moving sign attached and facing to the rear <input type="checkbox"/> | | | | |

South Padre Island License Plate #: _____

Inspected by

Owners Signature

Date of Inspection

**CITY OF SOUTH PADRE ISLAND
CITY COUNCIL MEETING
AGENDA REQUEST FORM**

MEETING DATE: July 17, 2019

NAME & TITLE: Debbie Huffman, Parks and Recreation Manager

DEPARTMENT: Parks and Recreation

ITEM

Discussion and action to approve a budget amendment to allocate funds in an amount \$500,000 to reflect the grant received from Texas Parks and Wildlife to complete Phase II of John L Tompkins Park.

ITEM BACKGROUND

The Texas Parks and Wildlife Commission has awarded the City of South Padre Island a Non-Urban Outdoor Recreational grant for Phase II of the John L. Tompkins Park. Phase II will include a skate park, a walking trail with exercise stations, benches, solar lighting, shade structures, bocce ball, additional play equipment and a soccer field. In 2015, the city developed two acres of public land with a TPWC grant of \$400,000. Phase I included the parking lot, restrooms, basketball court and playground equipment.

BUDGET/FINANCIAL SUMMARY

Increase line item 09-46068 by \$500,000
Increase line item 09-572-9177 by \$500,000

COMPREHENSIVE PLAN GOAL

Chapter III: Parks and Recreation

Goal 2: While utilizing nature-based recreational and tourism opportunities, the City shall also enhance the opportunities by providing trails, parks, plazas, and other recreational facilities and programs.

Strategy 2.1.2.3: The City shall identify continuous funding sources for sustainable parks and resources.

Strategy 2.1.2.4: Recreational sports facilities shall meet the needs of all age groups and be used by the Island's growing number of families with children.

LEGAL REVIEW

Sent to Legal: YES: _____
Approved by Legal: YES: _____

NO: X
NO: X

RECOMMENDATIONS/COMMENTS

Approve budget amendment.

**CITY OF SOUTH PADRE ISLAND
CITY COUNCIL MEETING
AGENDA REQUEST FORM**

MEETING DATE: July 17, 2019

NAME & TITLE: Aaron Hanley, AICP, AIA, NCI; Planning Director
Debbie Huffman, Parks & Recreation Manager
Kerry Schwartz, Council Member

DEPARTMENT: Planning Department/Parks & Recreation/City Council

ITEM

Discussion and action to proceed with Request for Qualifications for Design Services for the Skatepark portion of John L. Tompkins Park Phase II.

ITEM BACKGROUND

The Texas Parks and Wildlife Commission has awarded the City of South Padre Island a Non-Urban Outdoor Recreational grant for Phase II of the John L. Tompkins Park. Phase II will include a skate park, a walking trail with exercise stations, benches, solar lighting, shade structures, bocce ball, additional play equipment and a soccer field. In 2015, the city developed two acres of public land with a TPWC grant of \$400,000. Phase I included the parking lot, restrooms, basketball court and playground equipment. The Public Works Director, Alex Sanchez will be designing the majority of the park, however we are seeking qualified professional skatepark designers to design the skatepark portion of the project. The South Padre Island Skate Committee in coordination with the Parks and Keep SPI Beautiful Committee and City Staff have developed selection criteria and design scope to be included in the Request for Qualifications.

BUDGET/FINANCIAL SUMMARY

The TPWC Grant is a reimbursable grant, and therefore the expenditure for the design services will need to be paid by the City first. The City has a designated fund for the Skatepark of \$138,970. The cost of the design services will not be known until we have selected the most highly qualified professional and begin contract negotiations.

COMPREHENSIVE PLAN GOAL

Goal 3.J – Development should preserve and enhance the physical environment and natural features of the Island. Nature reserve areas, greenbelts, and open areas should be set aside for preservation and recreation and to be used as buffering areas.

12-1

Action 3.14 – Accumulate land throughout the Town to facilitate the building of additional public tourist attractions such as: parks, ...

Goal 5.S. – Design unique parks to meet the needs and desires of residents.

Goal 5.T. – Provide adequate park land concurrent with new development.

Action 5.53 – Continue to maintain and upgrade existing parks.

Goal 6.A. – Continue to coordinate fiscally responsible and well-managed growth with the provision of adequate public facilities and services.

Goal 7.B. Encourage more permanent residents and businesses.

Goal 7.E. Support an environment that is friendly to residents and businesses.

LEGAL REVIEW

Sent to Legal: YES: _____ NO: X
Approved by Legal: YES: _____ NO: _____

Comments:

RECOMMENDATIONS/COMMENTS

Staff recommends approving the issuance of the Request for Qualifications to move forward with the project.

**CITY OF SOUTH PADRE ISLAND
CITY COUNCIL MEETING AGENDA
REQUEST FORM**

MEETING DATE: July 17, 2019

NAME & TITLE: Kristina Boburka, Shoreline Director

DEPARTMENT: Shoreline Department

ITEM

Discussion and action to proceed or make changes to the proposed Palm Street Boat Ramp and Sunset Beach Access projects.

ITEM BACKGROUND

The improvements at Sunset Beach Access have been halted for some time due to backlash on the project. The Palm Street Boat Ramp has incurred additional design charges that were not accounted for due to the redesign of the ramp that included a larger pipe.

BUDGET/FINANCIAL SUMMARY

COMPREHENSIVE PLAN GOAL

Chapter III. Parks and Resources
GOAL 1: The City shall ensure protection and conservation of natural resources, such as beaches, dunes, wetlands, Laguna Madre waterfront and native flora and fauna, allowing for their sustainable use and enjoyment by future generations.
Objective 1.1 Beach and dunes shall be protected from both natural and artificial erosion.

LEGAL REVIEW

Sent to Legal: YES: _____ NO: X
Approved by Legal: YES: _____ NO: _____

RECOMMENDATIONS/COMMENTS

Staff supports.



Kristina Boburka <kboburka@myspi.org>

Palm Street boat ramp

1 message

Brandy Buntin <brandybuntin@gmail.com>
To: kboburka@myspi.org

Mon, Jul 8, 2019 at 12:36 PM

We need the boat ram finish at Palm st

We need a dock installed out from ram so that when anyone is launching there vessels they are able to back trailer into water float boat off and tie it up so that they can go and park there trailer and truck, leaving the boat tied up till they walk back and leave the dock, this is going to save all the boats hitting the bottom cause damage to equipment.

We are helping lots of people weekly because the existing ram has pot holes under water the tire and trailers are get damaged,

Brandy Buntin
808-640-7474

13-2

CONSTRUCTION PLANS FOR PALM STREET BOAT RAMP AUGUST 2018

PREPARED FOR
CITY OF SOUTH PADRE ISLAND, TEXAS

SHEET INDEX

1	COVER SHEET
2	GENERAL NOTES
3	EXISTING SITE AND DEMOLITION
4	PROPOSED SITE PLAN
5	EROSION CONTROL PLAN
6	PROPOSED PROJECT IMPACTS
7	BOAT RAMP CROSS-SECTION
8	WOOD PIER DETAILS
9	MISCELLANEOUS DETAILS

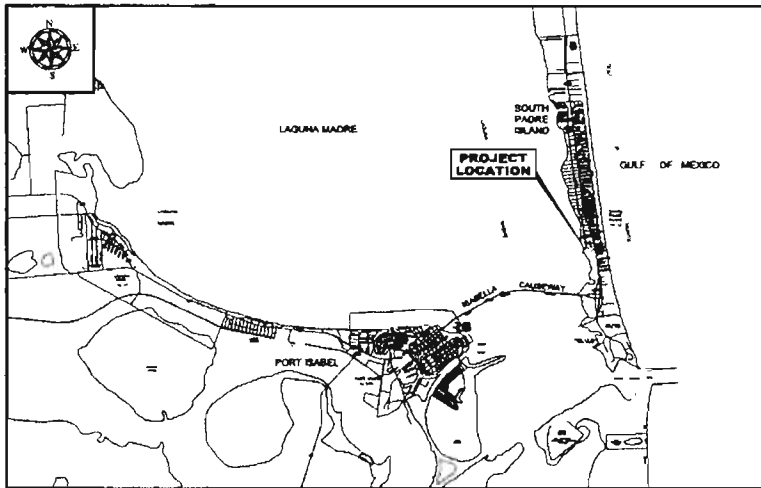

LOCATION MAP

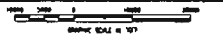

VICINITY MAP

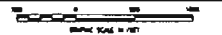

CITY COUNCIL

MAYOR	DENNIS STAHL
MAYOR PRO-TEM	PAUL MUNARRIZ
MEMBER	RON PITCOCK
MEMBER	THERESA METTY
MEMBER	ALITA BAGLEY
MEMBER	KEN MEDDERS, JR.
CITY MANAGER.....	SUSAN GUTHRIES

CALL BEFORE YOU DIG!



PARTICIPANTS REQUEST
48 HOURS NOTICE BEFORE YOU DIG,
DRILL, OR BLAST - STOP AND CALL

Where others dig, we dig.
Call before you dig.

811

THE LONE STAR
NOTIFICATION COMPANY
AT 1-800-669-8344



© Copyright Hanson Professional Services Inc. 2018

Hanson Professional Services Inc.
4501 Golfhar Rd.
Corpus Christi, Texas 78411
TBPE F-417 / TBPLS F-10038500 / TBAE F-8R 2458



FOR INTERIM
REVIEW
THIS DRAWING IS VALID
ONLY FOR THE PROJECT AND DATE
INDICATED ON THESE SHEETS.
NO OTHER PROJECTS OR
DATE CHANGES.
NO OTHER PROJECTS OR
DATE CHANGES.

Dep. No. 18,085

1

1 of 9 sheets

133

11/15/2018 10:30 AM (M) 10/15/2018 10:30 AM (M) 10/15/2018 10:30 AM (M)

LAGUNA MADRE



GRAPHIC SCALE IN FEET
0 25 50

LEGEND - EXISTING

- GAS
- EASEMENT
- WATERLINE
- FENCE
- TOP OF DITCH
- TOE OF DITCH
- CURB AND GUTTER
- UNDERGROUND POWER LINE
- STORM LINE
- FENCE
- ELEVATIONS
- BOLLARD
- CLEANOUT
- ELECTRIC TRANSFORMER
- FIRE HYDRANT
- FLAG POLE
- GAS VALVE
- GRATE INLET
- CUY WIRE
- IRON ROD
- IRRIGATION
- LIGHT POLE
- COMMUNICATION MANHOLE
- GAS MANHOLE
- SANITARY SEWER MANHOLE
- DRAINAGE MANHOLE
- PALM TREE
- PHONE ROSE
- POWER POLE
- SIGN
- TRAFFIC SIGNAL BOX
- TREE
- WATER METER
- WATER SPROUT
- WATER VALVE

LEGEND - PROPOSED

/// DEMO AREA

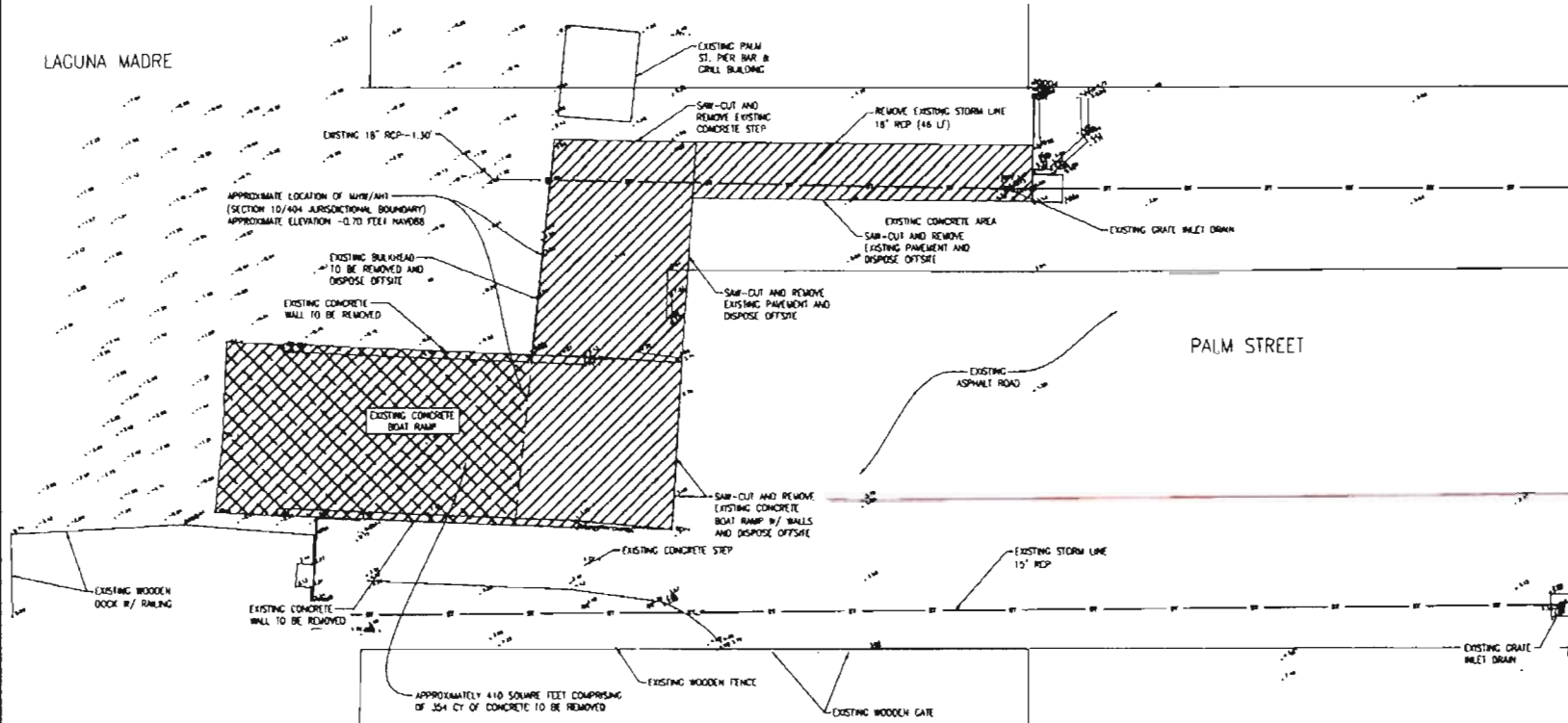

NOTES

1. CONTRACTOR SHALL LOCATE AND PROTECT UNDERGROUND UTILITIES.
2. CONTRACTOR SHALL NOTIFY ENGINEER IF AND WHEN DEVOLUTION CONTACTS ARISE.
3. EXISTING MATERIALS THAT ARE REMOVED SHALL BE DISPOSED OF PROPERLY OFFSITE, UNLESS OTHERWISE NOTED.

NUMBER	REVISION	DATE	DRAWN	DESIGNED	REVIEWED

FOR INTERIM REVIEW
 THE ENGINEER IS NOT PROVIDING A GUARANTEE OF ANY KIND FOR THE USE OF THIS PLAN BY ANYONE OTHER THAN THE CLIENT.
 THIS PLAN IS NOT TO BE USED FOR ANY OTHER PURPOSE.
 THE CITY OF SOUTH PADRE ISLAND IS NOT RESPONSIBLE FOR ANY DAMAGE TO PERSONS OR PROPERTY.



PROJECT No.	1810493
CLIENT	CITY OF SOUTH PADRE ISLAND
DATE	8/23/2018
LAYOUT	VM 8/23/2018
DESIGN	VM 8/23/2018
REVIEWED	PM 8/23/2018

HANSON
 Hanson Professional Services Inc.
 4601 Golphar Rd.
 Corpus Christi, Texas 78411

TS/PE F-417
 TS/PLS F-10028600
 TS/PO F-50058
 TS/AE F-5012458
 Phone: (361) 614-8800
 (800) 877-2831
 www.hanson-pal.com
 Offices: Houston

EXISTING SITE AND DEMOLITION PLAN
 PALM STREET BOAT RAMP
 CITY OF SOUTH PADRE ISLAND, TEXAS

13-5

STORM WATER POLLUTION PREVENTION PLAN AND DETAILS

EROSION CONTROLS

The Contractor shall install sediment control devices as soon as construction begins. The sediment control devices shall be installed around the perimeter of the project site along steep drainage ditches and the existing shoreline.

The Contractor shall control dust blowing and implement an construction site and roads to prevent loss of soil particles, to reduce noise and air quality damage, to prevent health hazards, and to improve traffic safety. The Contractor shall implement dust control measures immediately whenever dust can be observed blowing on the project site. One or more of the following methods shall be utilized by the Contractor for controlling dust: 1) Mulches bound with chemical binders such as Comcoat, Fortibond, or approved equal; 2) Temporary vegetative cover; 3) Spray-on adhesives on roadbed soils, which are not used by traffic; 4) Irrigation by water sprinkling; 5) Barriers using sand burlap fences, straw fences, burlap fences, straw bales, bales of hay, or similar materials.

The Contractor shall be responsible for cleaning up any leaking oils or fluids that may result from the use of this equipment, and report any such equipment that has been left overnight for extended periods or under maintenance. Spills and leaks require handling as discussed further in Construction Committee and Spills Section.

WASHING AREAS

The Contractor shall not wash vehicles such as ready-mix concrete or dump trucks and other construction equipment at locations where the runoff will flow directly into a structure or storm conveyance system. Spillout areas shall be designated for washing vehicles. These areas shall be located where the wash water will runoff out and evaporate or infiltrate directly into the ground, or where the runoff can be collected in a temporary holding or storage basin. Wash areas shall have gravel or crushed stone bases to minimize mud generation.

MAINTENANCE AND INSPECTION

The Contractor shall maintain erosion control devices on site and maintain structures proper control practices. This includes cleaning out sediments collected by all devices when 50% of the device capacity is exceeded or when designated by the owner's inspector. The Contractor shall clean around devices that have been covered by runoff at the earliest date possible after rainfall events. In addition, erosion control devices should be repaired no later than seven (7) calendar days after surrounding exposed ground has substantially dried. Areas adjacent to streams and drainage ditches have priority.

The site shall be inspected by the owner's inspector every 14 days or before anticipated weather events. Areas that should be inspected include disturbed areas, areas used for clearing materials, structural controls, areas where sediment piles and soil piles are areas that have been temporarily established. The inspector should evaluate the condition and proper function of erosion control devices, identify maintenance requirements and identify any additional corrective measures needed. A summary report of the inspection should be filed with the contractor. The report should include the names of the personnel conducting the inspection, the dates of the inspection and any problems or incidences of non-compliance. If necessary the Pollution Prevention Plan should be supplemented to include any recommendations made in the inspection report.

EQUIPMENT MAINTENANCE AND REPAIR

The Contractor shall conduct maintenance and repair of construction machinery and equipment to confined areas specifically designated for that purpose. Such designated areas should be fenced and designed to shut off, grease, oil, and other potential pollutants control be washed directly into receiving streams or storm water conveyance systems. The Contractor shall provide these areas with adequate water disposal receptacles for hand or self-wash work. Maintenance areas should be inspected and cleaned daily.

All locations throughout the site where designated equipment maintenance areas are not feasible, the Contractor shall take care during each individual repair or maintenance operation to prevent petroleum products from becoming available to be washed into streams or storm water conveyance systems. Temporary water disposal receptacles shall be provided by the Contractor as necessary.

The Contractor shall be responsible for monitoring all engine vehicles and equipment for leaks and perform regular preventative maintenance to reduce the chance of leakage. Petroleum products shall be stored in tightly sealed containers which are clearly labeled.

WASTE COLLECTION AND DISPOSAL

The Contractor shall not discharge solid materials, including building materials, into waters of the U.S. including any drainage areas, streams, water bodies, or bays. The Contractor shall formulate a plan for the collection and disposal of waste materials on the construction site. The plan shall describe methods for trash and waste receptacles and establish a regular collection schedule. Methods for ultimate disposal of waste must be specified and comply with all applicable local, state, and federal health and safety regulations. Special provisions shall be made for the collection disposal of liquid wastes and leaks or hazardous materials. The Contractor shall have receptacles and other waste collection areas located and clearly in the storm water runoff. Waste shall not be allowed to overflow the container or be discharged for secondary use purposes of use. Trash collection points shall be located where they will least likely be affected by concentrated storm water runoff.

CONSTRUCTION CHEMICALS AND SPILLS

The Contractor shall avoid sites where phenolics, solvents, acids, or other potential water pollutants are stored in areas where they will not cause runoff pollution.

The Contractor shall store toxic and/or other hazardous chemicals and materials, such as pesticides, paints, and solvents, in accordance with manufacturer's guidelines. The Contractor shall protect groundwater resources from leaching by placing a plastic mat, polythene, or other impervious materials on any areas where leaks and/or hazardous fluids are to be stored and stored.

The Contractor shall use and store materials used during construction in accordance with manufacturer's guidelines and with local, state and federal regulations. Containers shall be sealed and ground level shall be raised to prevent accidental spillage. Pesticide containers shall never be washed in or near storm water conveyance systems.

Immediately after discovery, the Contractor shall clean and treat spills of toxic and/or hazardous substances in accordance with local, state, and federal regulations.

The Contractor shall carry out in-site, the manufacturer's recommended methods for spill cleanup and Contractor's personnel will be made aware of the procedures and the location of the information and cleanup supplies. Any spills should be immediately contained to avoid soil runoff to drainage ditches, streams, or water bodies, or absorption and construction areas. All spills should be immediately reported to the project owner or owner representative.

The Contractor shall keep materials and equipment necessary for spill cleanup in the materials storage area. Equipment and materials shall include but are not limited to brooms, dust pans, mats, rags, gloves, goggles, heavy filter, sand absorbent, and plastic and metal trash containers specifically for this purpose.

SANITARY FACILITIES

The Contractor shall provide the construction site with adequate sanitary facilities for workers in accordance with applicable health regulations.

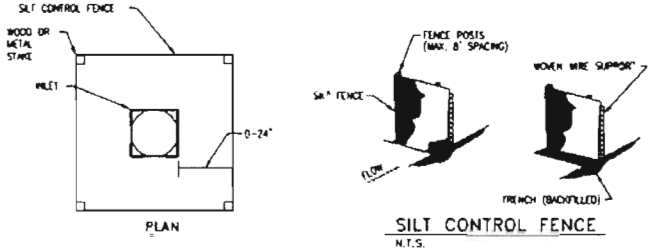
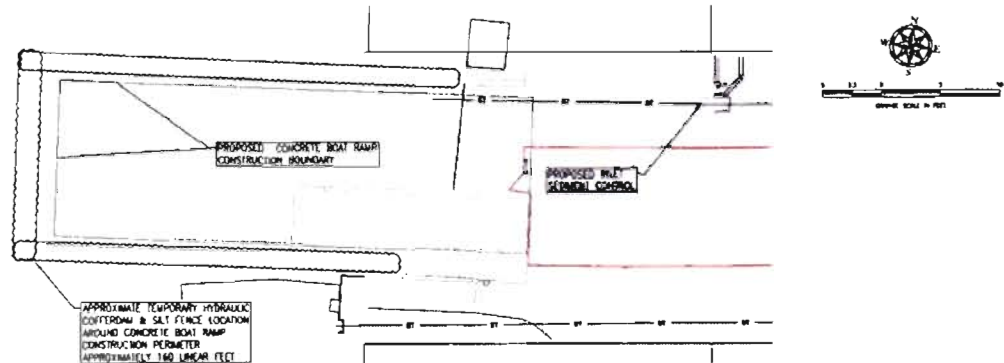

NOTES:

1. POSTS WHICH SUPPORT THE SILT FENCE SHALL BE INSTALLED ON A SLIGHT ANGLE TOWARD THE ANTICIPATED RUNOFF SOURCE.
2. THE TOP OF THE SILT FENCE SHALL BE TRENCHED IN WITH A SPACE OR MECHANICAL TRENCHER, SO THAT THE DOWN-SLOPE FACE OF THE TRENCH IS FLAT AND PERPENDICULAR TO THE LINE OF FLOW.
3. THE TRENCH SHOULD BE A MINIMUM OF 6 INCHES DEEP AND 3-4 FEET WIDE TO ALLOW FOR THE SILT FENCE TO BE LAID IN THE GROUND AND BACKFILLED.
4. SILT FENCE SHOULD BE SECURELY FASTENED TO EACH STEEL SUPPORT POST OR TO WOVEN WIRE, WHICH IS IN TURN ATTACHED TO THE STEEL FENCE POSTS.
5. INSPECTION SHALL BE FREQUENT AND REPAIR OR REPLACEMENT SHALL BE MADE PROMPTLY AS NEEDED.
6. SILT FENCE SHALL BE REMOVED WHEN IT HAS SERVED ITS USEFULNESS, SO AS NOT TO BLOCK OR IMPEDE STORM FLOW OR DRAINAGE.
7. SEDIMENT TRAPPED BY THIS PRACTICE SHALL BE DISPOSED OF IN AN APPROVED SITE IN A MANNER THAT WILL NOT CONTRIBUTE TO ADDITIONAL SEDIMENTATION.
8. ACCUMULATED SILT SHALL BE REMOVED WHEN IT REACHES A DEPTH OF 6 INCHES AND DISPOSED OF IN AN APPROVED SPOILS SITE OR AS IN NO. 7 ABOVE.

DATE: 08/23/2018 10:08 AM, NUMBER: 13-7, PROJECT: PALM STREET BOAT RAMP, DRAWING: STORM WATER POLLUTION PREVENTION PLAN AND DETAILS

13-7

NUMBER	REVISION	DATE	DRAWN	DESIGNED	REVIEWED

FOR INTERIM REVIEW
 USE INDICATED TO INDICATE FOR REVIEW OF THIS DRAWING BY THE PROJECT OWNER OR OTHER AUTHORITY.
 DATE: 8/23/2018
 BY: [Signature]



PROJECT NO.	140491
CLIENT	HANSON PROFESSIONAL SERVICES INC.
DATE	8/23/2018
LAYOUT	WJ 8/23/2018
DRAWN	WJ 8/23/2018
REVIEWED	PHJ 8/23/2018

HANSON
 Hanson Professional Services Inc.
 4001 Galveston Rd.
 Corpus Christi, Texas 78411

PHONE: (361) 814-8800
 (800) 677-2831
 www.hanson-inc.com
 Office: HANSON@HANSON-INC.COM

EROSION CONTROL PLAN

PALM STREET BOAT RAMP
 CITY OF SOUTH PADRE ISLAND, TEXAS

LAGUNA MADRE

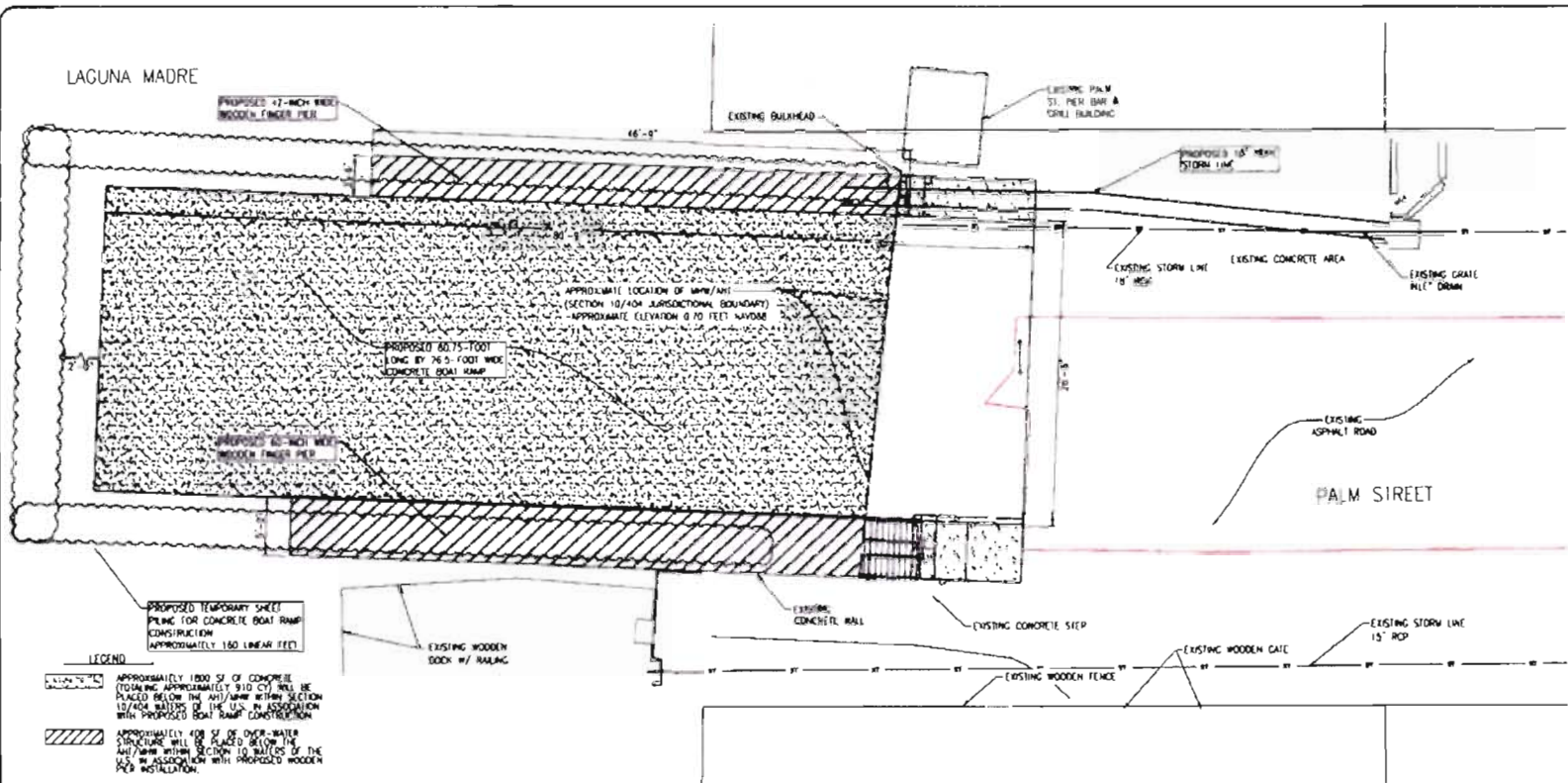
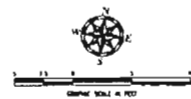

- LEGEND - EXISTING**
- GAS
 - EASEMENT
 - WATERLINE
 - FENCE
 - TOP OF BENCH
 - TOP OF SLOPE
 - CURB AND GUTTER
 - UNDERGROUND POWER LINE
 - GROUND LINE
 - FENCE
 - ELEVATIONS
 - WELLS
 - CLEANOUT
 - ELECTRIC TRANSFORMER
 - FIRE HYDRANT
 - FLAG POLE
 - GAS VALVE
 - GRATE INLET
 - CUI WIRE
 - IRON ROD
 - IRRIGATION
 - LIGHT POLE
 - COMMUNICATION MANHOLE
 - GAS MANHOLE
 - SANITARY SEWER MANHOLE
 - DRAINAGE MANHOLE
 - PALM TREE
 - PHONE RISER
 - POWER POLE
 - SIGN
 - TRAFFIC SIGNAL BOX
 - TREE
 - WATER METER
 - WATER SPOUT
 - WATER VALVE

PROPOSED TEMPORARY SHEET PILING FOR CONCRETE BOAT RAMP CONSTRUCTION (APPROXIMATELY 150 LINEAR FEET)

LEGEND

- APPROXIMATELY 1800 SF OF CONCRETE (TOTALING APPROXIMATELY 310 CY) WILL BE PLACED BELOW THE WATERSIDE SECTION IN/4/2014 MATTERS OF THE U.S. IN ASSOCIATION WITH PROPOSED BOAT RAMP CONSTRUCTION.
- APPROXIMATELY 400 SF OF OVER-WATER STRUCTURE WILL BE PLACED BELOW THE AIR/WATER SECTION TO RAISES OF THE U.S. IN ASSOCIATION WITH PROPOSED WOODEN PCB INSTALLATION.

NOTE: COFFERDAM SHALL BE A HYDRAULIC COFFERDAM OR APPROVED EQUAL BY ENGINEER

13-8
 ALL DIMENSIONS ARE IN FEET UNLESS OTHERWISE SPECIFIED. PROPOSED DIMENSIONS ARE SHOWN IN RED.

NUMBER	REVISION	DATE	DRAWN	DESIGNED	REVIEWED

FOR INTERIM REVIEW

ALL DIMENSIONS ARE IN FEET UNLESS OTHERWISE SPECIFIED. PROPOSED DIMENSIONS ARE SHOWN IN RED.



Drawn	16/04/21
Checked	16/04/21
Date	8/23/2018
Reviewed	8/23/2018



TS/PS F-417
 TS/PS F-10236601
 TS/PS F-502538
 TS/PS F-502548

Phone: (761) 814-8900
 (800) 877-2451
 www.hansoninc.com
 Offices Nationwide

PROPOSED PROJECT IMPACTS

PALM STREET BOAT RAMP
 CITY OF SOUTH PADRE ISLAND, TEXAS

6

8 of 10 sheets

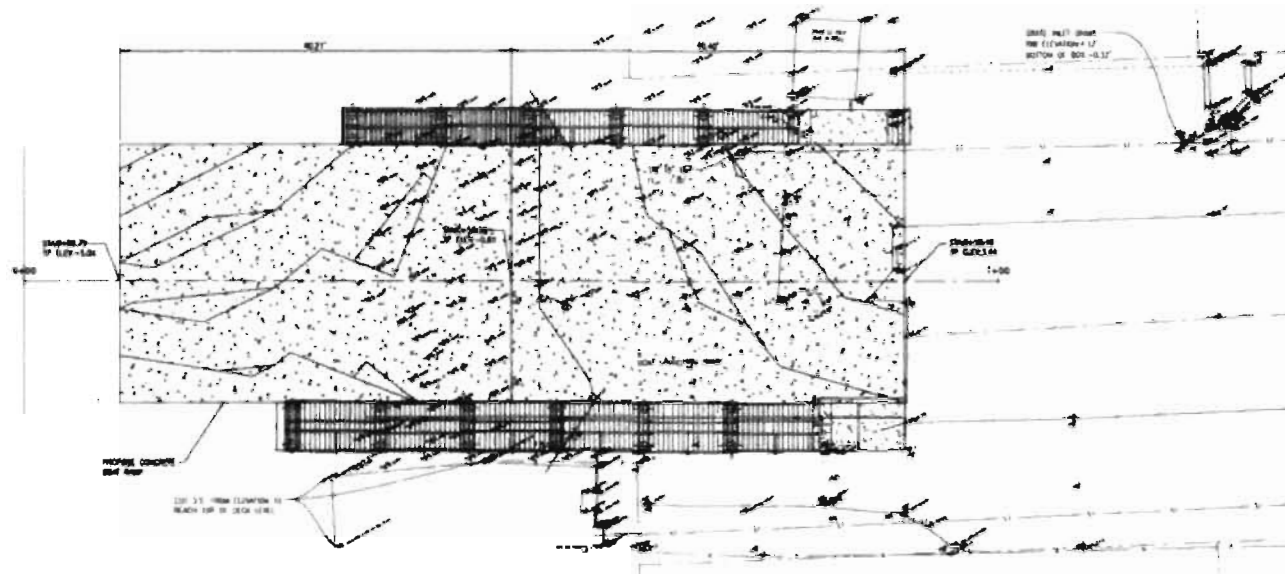

BOAT RAMP CROSS SECTION

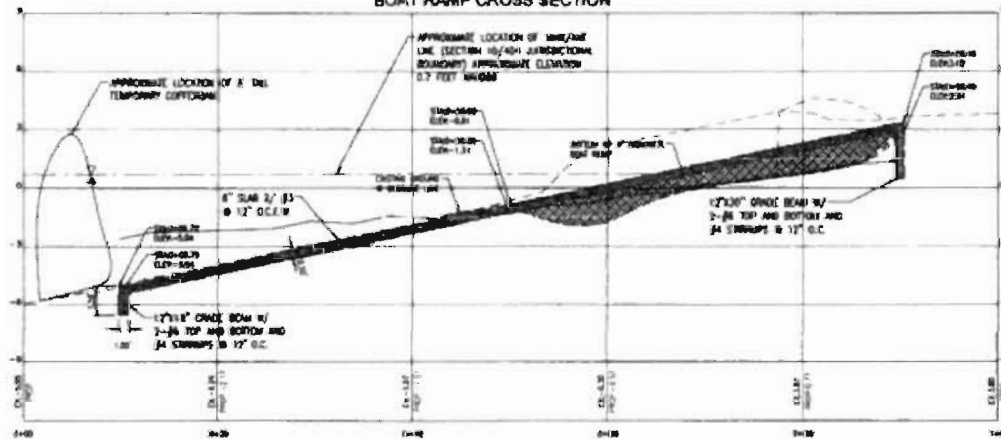

Cut/Fill Summary

Item	Qty	Factor	Fill	Factor	Sp Area	Dist	Dist	Dist
Prep to 24' Top Vol	5,000	1.000	2257.00	0.0	FL	42.14	0.0	0.0
Prep to 24' 12" Vol	2,000	1.000	2129.00	0.0	FL	39.32	0.0	0.0
AVAL 4873 CY						AVAL 0.00 CY		

13-9

NO.	REVISION	DATE	BY	CHKD	DESCRIPTION

FOR SYSTEM REVIEW
 ALL DIMENSIONS IN INCHES UNLESS OTHERWISE NOTED
 ALL DIMENSIONS TO FACE UNLESS OTHERWISE NOTED
 ALL DIMENSIONS TO CENTERLINE UNLESS OTHERWISE NOTED
 ALL DIMENSIONS TO CENTERLINE UNLESS OTHERWISE NOTED
 ALL DIMENSIONS TO CENTERLINE UNLESS OTHERWISE NOTED



DATE	10/04/11
SCALE	AS SHOWN
DESIGNED BY	AV/AVS
CHECKED BY	AV/AVS
DATE	10/04/11

HANSON
 Hanson Professional Services Inc.
 4321 Gateway Rd
 Corpus Christi, Texas 78411

BOAT RAMP CROSS-SECTION
 PALM STREET BOAT RAMP
 CITY OF SOUTH PADRE ISLAND, TEXAS

7

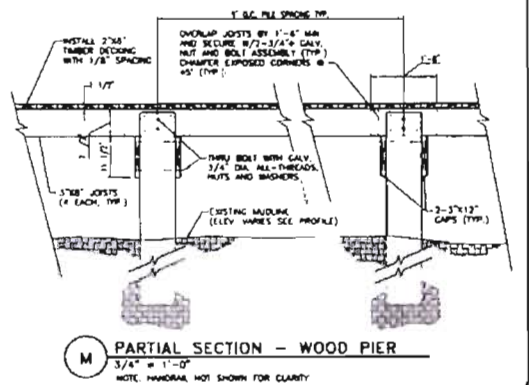
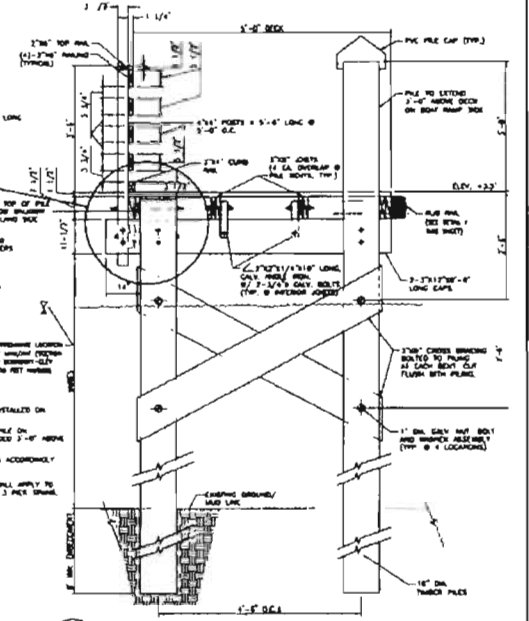
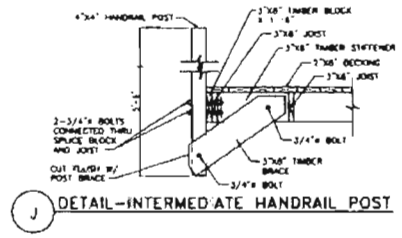
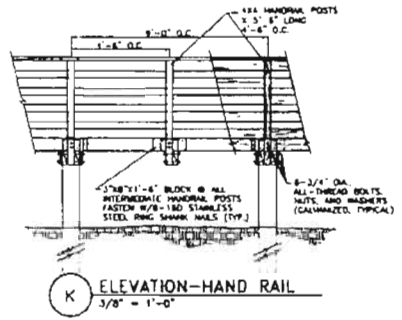
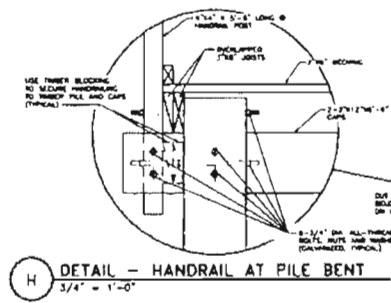
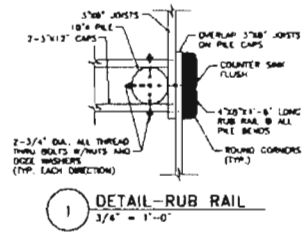
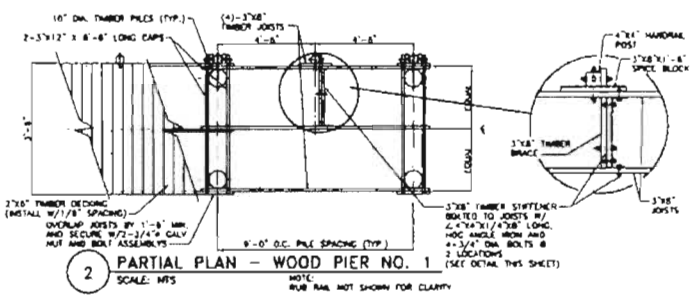
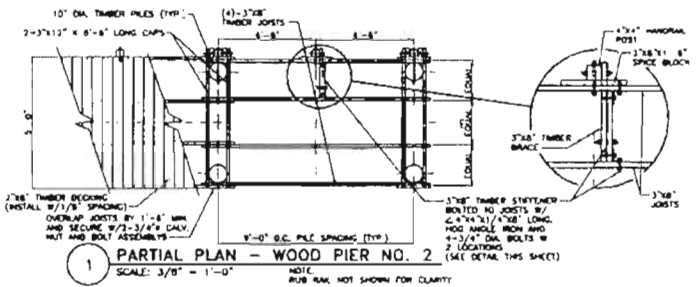

- NOTE 1: HANDRAIL TO BE INSTALLED ON LAND SIDE ONLY.
NOTE 2: PILES SHALL HAVE PILE ON WATER SIDE EXTENDED 3'-0" ABOVE DECK.
NOTE 3: ALL DIMENSIONS ACCORDINGLY FOR PER NO. 1.
NOTE 4: CROSS BRACING SHALL APPLY TO ONLY THE DEEPEST 3 PIER FRAME.

NO.	REVISION	DATE	DRAWN	CHECKED	REVIEWED

FOR INTERIM REVIEW
 ALL DIMENSIONS IN INCHES UNLESS OTHERWISE NOTED
 ALL DIMENSIONS IN FEET UNLESS OTHERWISE NOTED
 ALL DIMENSIONS IN METERS UNLESS OTHERWISE NOTED
 ALL DIMENSIONS IN MILLIMETERS UNLESS OTHERWISE NOTED
 ALL DIMENSIONS IN CENTIMETERS UNLESS OTHERWISE NOTED
 ALL DIMENSIONS IN DECIMETERS UNLESS OTHERWISE NOTED
 ALL DIMENSIONS IN KILOMETERS UNLESS OTHERWISE NOTED



DATE: 8/21/2018	DESIGNED: [Signature]
DRAWN: [Signature]	CHECKED: [Signature]
REVIEWED: [Signature]	DATE: 8/21/2018



TSPE F-12
 TSPS F-10038000
 TSPC F-102558
 TBAE F-1R 2458

Phone: (811) 814-8800
 (800) 871-2831
 www.hanson-inc.com
 Offices Nationwide

WOOD PIER & DETAILS

PALM STREET BOAT RAMP
 CITY OF SOUTH PADRE ISLAND, TEXAS

13-1b



GRAPHIC SCALE IN FEET

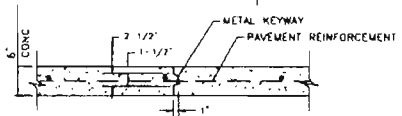
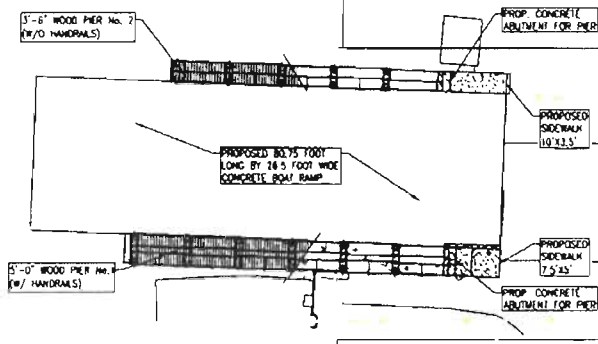

CONSTRUCTION JOINT
SCALE: N15

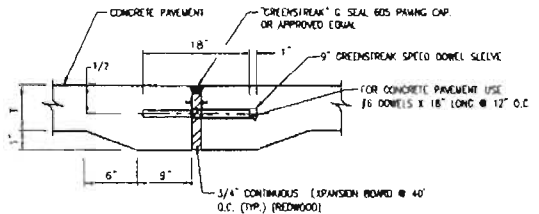

NOTE:
1. PLACE EXPANSION JOINT EVERY 40' (TYP.) IN EACH DIRECTION UNLESS INDICATED OTHERWISE ON THE PLAN SHEET.

CONCRETE PAVEMENT EXPANSION JOINT
N.T.S.

CONSTRUCTION NOTES:

1. THE CONTRACTOR, AT HIS EXPENSE, SHALL COLLECT SAMPLES OF SUBGRADE AND PROPOSED BASE MATERIALS, AND SUBMIT TO A GEOTECHNICAL TESTING LABORATORY FOR ESTABLISHMENT OF AN OPTIMAL SOIL MOISTURE AND DENSITY PROCTOR, AS CALLED FOR IN THE PLANS. COPIES OF THESE REPORTS SHALL BE PROVIDED TO THE ENGINEER IN ADVANCE OF CONTRACTOR PERFORMING THIS WORK TO ENABLE REVIEW AND FIELD VERIFICATION.
2. THE CONTRACTOR SHALL COORDINATE WITH THE SAME GEOTECHNICAL FIRM NOTED ABOVE TO HAVE THEM VERIFY FIELD DENSITY AND MOISTURE FOR THE ESTABLISHED PROCTOR. IF ACCEPTABLE FIELD TESTS ARE INDICATED, FORTHCOMING AND REINFORCING STEEL SHALL IMMEDIATELY BE PLACED IN THE PROPOSED PAVEMENT AREA, AND CONCRETE SHALL BE READY TO POUR WITHIN FORTY-EIGHT (48) HOURS.
3. IF THE ENGINEER DETERMINES THAT SIGNIFICANT WEATHER CONDITION FLUCTUATIONS (I.E. EXCESS RAINFALL, EXCESS TEMPERATURE CHANGE, ETC.) HAVE OCCURRED WITHIN 48 HOURS OF THE TIME THE FIELD MEASUREMENTS FOR DENSITY AND MOISTURE WERE RECORDED, RE-TESTING OF THESE FIELD MEASUREMENTS SHALL OCCUR AT THE OWNER'S EXPENSE.
4. IF THE 48 HOUR TIME PERIOD HAS BEEN EXCEEDED AND NO FURTHER OF THE OWNER AND/OR WEATHER CONDITION FLUCTUATIONS, THE FIELD MEASUREMENTS FOR DENSITY AND MOISTURE SHALL BE RE-TESTED AT THE EXPENSE OF THE CONTRACTOR.
5. AS INDICATED IN THE PROJECT SPECIFICATIONS, CONTRACTOR SHALL MAINTAIN, AT ALL TIMES, ADEQUATE CONSTRUCTION FENCING AND BARRICADES AROUND THE ENTIRE WORK AREA TO PREVENT PUBLIC ACCESS TO THE CONSTRUCTION AREA, PARTICULARLY HAZARDOUS INCLUDING TRIPPING AND FALLING.
6. THE CONTRACTOR SHALL POUR AT MINIMUM OF 50 CY OF CONCRETE AT A TIME (OR LESS IF AN ENTIRE CAMPUIS SITE IS LESS THAN THIS VOLUME) IN ORDER TO COMPLETE THE PROJECT'S COMPLETION. FOR SITES THAT HAVE POUR VOLUMES GREATER THAN 50 CY, CONTRACTOR WILL NOT BE ALLOWED TO POUR LESS THAN THIS VOLUME, UNLESS PRE-APPROVED BY THE PROJECT ENGINEER AND/OR THE DISTRICT.
7. EXPANSION JOINTS (GREENSTREAK G SEAL CAP 610 OR 629) SHALL BE PLACED AT A MAXIMUM SPACING OF 40 FEET ON ALL VERTICAL AND HORIZONTAL CONCRETE (I.E. FLATWORK AND CURBS). CONTROL JOINTS SHALL BE PLACED AT A MAXIMUM SPACING OF 15 FEET (PREFERRED SPACING IS 10 FEET) USING THE FOLLOWING GUIDE: 1 INCH TOOL DEPTH PER CONCRETE THICKNESS (I.E. 5 INCH CONCRETE NEEDS A TOOL DEPTH OF 1.25 INCH).
8. NEW CONCRETE SHALL BE DOWELED INTO EXISTING CONCRETE, UTILIZING AN EPOXY ADHESIVE ANCHOR (HOLD NO. M1, RE 500, OR ENGINEER APPROVED EQUAL). FOR EXISTING STANDARD CURBS, UTILIZE NO. 4 BARS AT 18 INCHES ON CENTER WITH A MINIMUM EMBEDMENT LENGTH OF 4 INCHES INTO THE BOTTOM OF THE CURB, AND FOR EXISTING 4 INCH SIDEWALKS, UTILIZE A NO. 3 BAR AT A MINIMUM OF 14 INCHES ON CENTER WITH A MINIMUM EMBEDMENT LENGTH OF 6 INCHES. IN ALL INSTALLATIONS, MAKE SURE THE DRILL IS HORIZONTAL TO ENSURE PROPER DOWEL INSTALLATION, FUNCTION AND NO PROTRUDING DOWELS THROUGH EXISTING CONCRETE.
9. AS INDICATED HEREIN AND IN THE SPECIFICATIONS, THE OWNER WILL BE RESPONSIBLE FOR THE COSTS OF FIELD MOISTURE AND DENSITY TESTS ON SUBGRADE AND BASE MATERIALS, CONCRETE CYLINDER TESTS, AND OTHER REQUIRED RE-TESTS, THAT THE ENGINEER DETERMINES TO BEYOND CONTRACTOR'S CONTROL, THAT ARE NECESSARY TO ENSURE COMPLIANCE WITH PROJECT SPECIFICATIONS.
10. THE CONTRACTOR SHALL BE RESPONSIBLE FOR THE COSTS OF OPTIMAL SOIL MOISTURE AND DENSITY PROCTORS OF SUBGRADE AND BASE MATERIALS, AND ANY RE-TESTS REQUIRED DUE TO INITIAL AND/OR SUBSEQUENT GEOTECHNICAL TESTS INDICATING NON-COMPLIANCE WITH THE PROJECT SPECIFICATIONS.
11. THE CONTRACTOR IS TO UNDERSTAND THAT THE SUBSTANTIAL COMPLETION DEADLINE IMPLIES THAT THE PAVING SURFACE HAS ACHIEVED DESIGN STRENGTH AS DETERMINED BY GEOTECHNICAL TESTING FIRM, CONCRETE CYLINDER BREAK REPORTS, AND THE SURFACE IS READY FOR USE. THIS DEADLINE ALSO IMPLIES THAT THE CONTRACTOR HAS COMPLETED ANY PUNCHLIST ITEMS THAT WERE ISSUED BY THE ENGINEER AND/OR THE DISTRICT. THE CONTRACTOR IS TO PLAN HIS WORK ACCORDINGLY TO MEET THIS DEADLINE.
12. AS NECESSARY, THE CONTRACTOR SHALL REPAINT ALL CURBS AND PARKING SPACE LABELS THAT ARE IN THE CONSTRUCTION AREA.

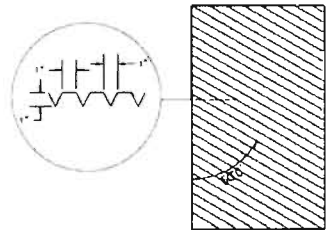

V-GROOVE CONCRETE FINISH DETAIL
N.T.S.

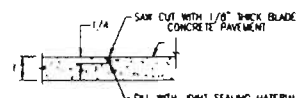

NOTE:
1. 1ST SAW-CUT SHALL BE WITHIN 15 HRS AFTER CONCRETE PLACEMENT
2. 2ND SAW-CUT SHALL PROVIDE NECESSARY SHAPE FACTOR FOR JOINT SEALING MATERIAL (CLASS 5 SEALANT DOWN CORNING 890-SL SELF-LEVELING SILICONE JOINT SEAL OR APPROVED EQUAL.)
3. PLACE CONTROL JOINT EVERY 10' (TYP.) IN EACH DIRECTION UNLESS INDICATED OTHERWISE ON THE PLAN SHEET

CONCRETE PAVEMENT CONTROL JOINT DETAIL
N.T.S.

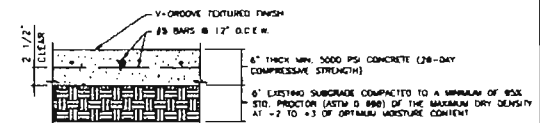

BOAT RAMP CONCRETE PAVEMENT
N.T.S.

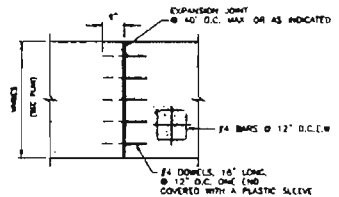

4\"/>

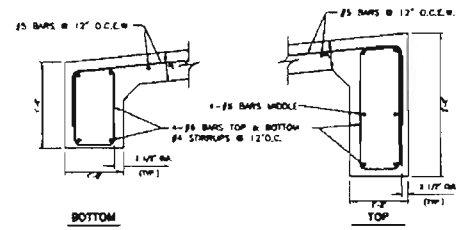

SECTIONS-CONCRETE RAMP GRADE BEAMS
N.T.S.

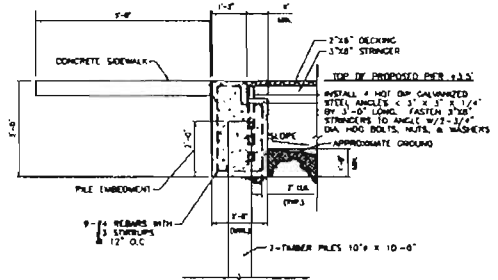

SECTION-CONCRETE ABUTMENT FOR FIXED PIER
N.T.S.

NUMBER	REVISION	DATE	DRAWN	DESIGNED	REVIEWED

FOR INTERIM REVIEW
HAS APPROVED & RELEASED THE CONTRACTOR FROM LIABILITY FOR THE WORK SHOWN HEREON IF THE WORK IS DONE IN ACCORDANCE WITH THE CONTRACT DOCUMENTS AND THE PLAN SHEET.



DATE: 8/28/2018
DRAWN: VM
REVIEWED: PMP



TBPE F-417
TBPLS F-10028500
TBPO F-30505
TBAE F-BR 2458

MISCELLANEOUS DETAILS
PALM STREET BOAT RAMP
CITY OF SOUTH PADRE ISLAND, TEXAS

13-11

**CITY OF SOUTH PADRE ISLAND
CITY COUNCIL MEETING
AGENDA REQUEST FORM**

MEETING DATE: July 17, 2019

NAME & TITLE: Ed Caum, CVB Director

DEPARTMENT: Convention and Visitors Bureau

ITEM

Discussion and action to approve a three-year contract term with Pro WaterCross and authorize the City Manager to sign the contract.

ITEM BACKGROUND

The Convention and Visitors Advisory Board approved a three-year contract with Pro WaterCross at their regular meeting held on Wednesday, June 26, 2019 and recommended to City Council for approval. The funding amount is \$35,000 for operational costs per year and in-kind services up to \$15,000.

BUDGET/FINANCIAL SUMMARY

02-593-8099 Special Events Budget - \$35,000 sponsorship per year.

COMPREHENSIVE PLAN GOAL

Policy 1.1.1: The City should identify and target consumer populations for the various recreational activities and businesses the island offers (i.e., kite boarders, windsurfers, eco-tourists, winter visitors, artists, music, cultural enthusiasts, athletic competitors, etc.)

LEGAL REVIEW

Sent to Legal: YES: X NO:
Approved by Legal: YES: NO:

RECOMMENDATIONS/COMMENTS

Approve the three-year contract with Pro WaterCross and authorize the City Manager to sign the contract.

14-1

Please keep this proposal confidential



PRO WATERCROSS TOUR AND SOUTH PADRE ISLAND CONVENTION & VISITORS BUREAU FOR SOUTH PADRE ISLAND, TEXAS – 2020, 2021 & 2022

The Pro Watercross Tour/UWP and the South Padre Island Convention & Visitors Bureau agree to a three (3) year contract for a Pro Watercross Tour stop 2020, 2021, 2022 – to be held the first weekend in June each year.

SERVICES PROVIDED TO SOUTH PADRE ISLAND, TX FOR A PRO WATERCROSS NATIONAL TOUR STOP:

UWP, LLC shall conduct a Pro Watercross Tour stop in South Padre Island, Texas and if it is agreed between the parties that UWP, LLC, in connection with the Pro Watercross, shall:

- Provide a two-day event professionally run and designed to entertain an audience for a minimum of five to six hours each day, Saturday & Sunday: Watercross racing.
- Produce and distribute one (30) minute Pro Watercross TV shows that will highlight the racing.
- South Padre Island Convention & Visitors Bureau will receive two (2):30 second TV commercials.
- One (1) 45-60 second segment within the TV show to promote the South Padre Island, Texas region.
- South Padre Island Convention & Visitors Bureau will receive closing billboards during the television show.
- Web cast - two 3-4-hour broadcasts, one on Saturday and one on Sunday which will include a minimum of two :30 second commercials each day.
- Logo placement throughout the event venue, which will include four (4) courtside banners at each Pro Watercross event.
- Logo placement on the front side of the main stage, the main stage/tower is the focal point of the on-land entertainment.
- PA announcements at each Tour Stops.
- South Padre Island Convention & Visitors Bureau logo inclusion on E-blasts throughout each year's campaign.
- South Island Convention & Visitors Bureau logo inclusion in E-blasts leading up to, during and post event recap.
- South Padre Island Convention & Visitors Bureau logo inclusion in social marketing campaigns including lead up to the South Padre Island, Texas event, pre-event and post event videos on YouTube, Facebook, e-blasts.
- South Padre Island Convention & Visitors Bureau logo inclusion on print media including event posters and postcards.
- South Padre Island Convention & Visitors Bureau linked logo & video inclusion on the Pro Watercross website and other digital media.

14-2

COST TO HOST SITE FOR EVENT

Host fee, cost and other obligations. As consideration for the rights and benefits granted herein and provided that UWP, LLC is in compliance with the terms of this Agreement, Agent and or Host and shall provide the following at no cost to UWP, LLC dba Pro Watercross:

- Rights fee: South Padre Island Convention & Visitors Bureau will pay UWP, LLC. the rights fee of \$35,000 of which \$26,250 or 75% will be paid upon the signing of contract and \$8,750 or 25% within 30 days post event. Remaining payments will be paid based on the payment schedule listed below.
 - Host guarantees the event site, free of charge, starting Wednesday before the Event through Sunday or the completion of the Event if later.
 - Assistancess in moving equipment from UWP trailer down to the beach (frontend loader or similar) on Thursday and Friday and removal on Sunday – times to be determined at a later date.
 - Assistance from South Padre Island Beach Patrol/Lifeguards (4-6 persons each day) on Saturday and Sunday to keep swimmers and beach goers from the immediate racecourse area for the duration of the event each day.
 - Host is responsible for overseeing water traffic control through communication with local marinas, boat patrols, and signage in appropriate locations.
 - Dedicated Ambulance with a minimum of two EMTs each day throughout the event weekend from approximately 9AM – 5PM on Saturday and Sunday.
 - Provide participants/event parking & security.
 - A minimum of thirty (30) Facebook posts and thirty (30) twitter posts on South Padre Island Convention & Visitors Bureau social accounts about the tour stop in South Padre Island, Texas for each upcoming event. Pro Watercross can provide pictures and graphics upon request.
 - Advertising promotion – local advertising in print and other sources (if available), which must be pre-approved by UWP, LLC before commitment is made.
 - Provide UWP, LLC with marketing material to help promote your community.
 - Provide UWP, LLC with 4 volunteers each day throughout the event weekend.
 - Provide UWP, LLC with hotel accommodations equaling 30 room nights for the event weekend UWP staff near the race site.
 - Please keep confidential all terms of this Agreement.

IN WITNESS WHEREOF, the parties have hereunto set their hands and seal this _____ day in the month of _____ 2019.

UWP, LLC Representative

South Padre Island Convention & Visitors Bureau Representative

Rights fee to be paid to the UWP, LLC for event: \$35,000 of which \$26,250 or 75% will be paid upon the signing of contract and \$8,750 or 25% within 30 days post event and post event report review by the City of South Padre Island's Convention and Visitor's Advisory board.

*Rights Fee payment schedule 2020, 2021, 2022 - **this is a three (3) year contract** for \$35,000 per year.*

- **2020 payment schedule:** \$35,000 of which \$26,250 or 75% will be paid upon the signing of contract and \$8,750 or 25% within 30 days post event
- **2021 payment schedule:** \$35,000 of which \$26,250 or 75% will be paid on or before October 1, 2020 and \$8,750 or 25% within 30 days post event
- **2022 payment schedule:** \$35,000 of which \$26,250 or 75% will be paid on or before October 1, 2021 and \$8,750 or 25% within 30 days post event

The event dates for the Pro Watercross National tour stop – South Padre Island Nationals: Tentative dates:

- June 6-7, 2020
- June 5-6, 2021
- June 4-5, 2022

14-3

SPI CVB Representative: _____ Initials

UWP representative: _____ Initials

SPONSORSHIP/PROMOTIONS

The event host will be entitled to all promotional, sponsorship, and merchandising dollars it raises pertaining to the watercross event, as well as all spectator and ancillary event gate fees, if applicable. The Pro Watercross National tour is entitled to all series promotional, sponsorship, and merchandising dollars it raises.

The Pro Watercross National Tour agrees to honor all event sponsorship commitments regarding signage, booth space, etc., that the host site makes pertaining to the watercross race, while the host site agrees to honor all commitments regarding booth space, signage, etc., made by the Pro Watercross National Tour.

The rights to the sale of soft goods merchandise pertaining specifically to the Pro Watercross National Tour are retained by the Tour and the Tour reserves the right to have the series' soft goods area at the event. It is understood that a copy of the insurance policy is available, upon request, and that also, upon request, the host site can name up to three additional insured on said policy.

END RESULT

The Pro Watercross National Tour offers host cities/venue the opportunity to bring an exciting and entertaining event to the community. The Pro Watercross National Tour will generate a tremendous amount of publicity, exposure for your area, and bring a substantial amount of money to the region.

The appeal of pro watercross racing will send out a message to the other lifestyle enthusiasts that something is happening in your area. On race weekend, people from all over the USA will descend on the city, fill hotels, and spend money in the local community. The added publicity will build traffic that will in turn generate more revenue for the city and the entire area.

Our mutual goal should be to establish a relationship between the event and the city that is a win-win for all those involved. UWP, LLC would like to establish a *long-term* relationship with host city. Thank you for your consideration to host a tour stop on the Pro Watercross National Tour. If you have any questions or need additional information, please call AJ at 585-330-0742.

Signature & deposit constitutes a binding three-year contract between South Padre Island Convention & Visitors Bureau Association and UWP, LLC for a tour stop for 2020, 2021, 2022.

This Agreement may be terminated upon 30 days written notice without cause or penalty, by either party.

South Padre Island CVB Representative's Signature _____

Name & Title: _____

Date: _____

14-4

UWP Representative's Signature: _____

Name & Title: _____
(Printed)

Date: _____

14-5

**CITY OF SOUTH PADRE ISLAND
CITY COUNCIL MEETING
AGENDA REQUEST FORM**

MEETING DATE: July 17, 2019

NAME & TITLE: Mark Shellard, Information Technology Director

DEPARTMENT: Information Technology Department

ITEM

Discussion and action to approve a budget amendment in the amount of \$49,999.55 for the replacement of three virtualization servers and backup hardware and associated software.

ITEM BACKGROUND

The City of South Padre Island operates a Microsoft Windows domain controller, Police Department CAD and RMS server and financial software server in a virtualized server environment. On May 20th 2019 the storage that runs the virtual servers failed and the IT Department used backups to bring the servers back online. The servers that failed are 10 years old and were considered end of life 4 years ago by the manufacturer.

The City of South Padre IT Department will be replacing the failed servers with 2 virtual hosts located at City Hall and one fail over server located at the Multimodal facility. This will ensure backups are done hourly and will result in zero down time in the event of a system failure and will have support and warranty for years to come.

The servers to be purchased include the following:

- 1 Buffalo 24TB Terastation NAS to store backups locally.
- 2 Dell PowerEdge R440 servers as Hypervisors.
- 1 Dell EMC ME4012 Storage Array.
- 1 Dell PowerEdge R540 as a failover server.
- Acronis Backup software
- VMWare Essentials Plus kit for up to 6 processors, Includes ESXI, Data Protection, vMotion, vShield Endpoint, vCenter, High Availability, Cross Switch vMotion, and Replication.

BUDGET/FINANCIAL SUMMARY

The budget amendment includes hardware warranty for 5 Servers, Software and the first year of Maintenance.

Increase line item 01-515-1004 by \$49,999.55.

The current level of excess reserves in the General Fund is approximately \$890,000.

COMPREHENSIVE PLAN GOAL

This item directly supports comprehensive plan goal 6.J “Continue to support the needs of the Public Works, Police and Fire Departments to ensure adequate protection of the population.”

LEGAL REVIEW

Sent to Legal: YES: _____ NO: X
Approved by Legal: YES: _____ NO: X

RECOMMENDATIONS/COMMENTS

The Information Technology Department recommends City Council approve purchase with this budget amendment. This will provide the much needed server setup that will ensure city services continue to operate smoothly for years to come.