

**NOTICE OF REGULAR MEETING
CITY OF SOUTH PADRE ISLAND
CITY COUNCIL MEETING**

NOTICE IS HEREBY GIVEN THAT THE CITY COUNCIL OF THE CITY OF SOUTH PADRE ISLAND, TEXAS, WILL HOLD A REGULAR MEETING ON:

WEDNESDAY, OCTOBER 6, 2010

5:30 P.M. AT THE MUNICIPAL BUILDING,
JOYCE H. ADAMS BOARD ROOM, 2ND FLOOR
4601 PADRE BOULEVARD, SOUTH PADRE ISLAND, TEXAS

1. Call to order
2. Pledge of Allegiance
3. Public Comments and Announcements: *This is an opportunity for citizens to speak to Council relating to agenda or non-agenda items. Speakers are required to address Council at the podium and give their name before addressing their concerns. [Note: State law will not permit the City Council to discuss, debate or consider items that are not on the agenda. Citizen comments may be referred to City Staff or may be placed on the agenda of a future City Council meeting]*
4. Presentations and Proclamations:
 - a. Proclamation: Native Plant of the Month for October 2010:
 - b. Proclamation: Children's Book of the Month for October 2010: *Here's a Little Poem: a very first book of poetry collected by Jane Yolen and Andrew Fusek Peters*
 - c. Proclamation: October 2010 designated as Breast Cancer Awareness Month
5. Approve Consent Agenda:
 - a. Approve minutes of September 9, 2010 Special Meeting, and Workshop and Regular meeting of September 15, 2010. (Hill)
 - b. Approve invoices for payment. (Homan)
 - c. Approve Lease Agreement for the use of one AutoMark (Voter Assist Terminals) during the November 2, 2010 Special Election. (Hill)
 - d. Approve Resolution No. 2010-26 authorizing the submission of three grant applications to the Texas General Land Office ("GLO") Texas Coastal Management Plan ("CMP") and authorizing a designated official to execute all documents and application forms on behalf of the City of South Padre Island. (Trevino)
 - e. Approve acceptance of FTA grant in the amount of \$26,593 for the installation of security cameras on WAVE buses. (Vasquez/Arriaga)
 - f. Approve Resolution No. 2010-27 supporting the Bikefest Bubba Blackwell Motorcycle Jump on October 8, 2010 and supporting the temporary closure of part of Padre Boulevard (Highway 100) for the event. (Quandt)
 - g. Approve Second and Final Reading of Ordinance No. 10-29 amending Chapter 4, Article 1, Section 4-5(A) by providing for the adoption of the 2009 International

- Residential Code without Section P2904 and modification of the exception in Section R302.2. (Mitchim)
- h. Approve Second and Final Reading of Ordinance No. 10-30 amending Chapter 4, Article V and Chapter 20, Section 20-8.3(C) of the Code of Ordinances, repealing Resolution No. 2009-30 and creating the Development Standards Review Task Force. (Clarke)
 - i. Approve Resolution No. 2010-28 requesting the Texas Legislature increase funding for the Texas Recreation and Parks Account Local Park Grant Program. (Jones)
6. Discussion and action to appoint members to expiring and/or new terms of the Town's committees, boards and commissions. (City Council)
 - a. Bay Area Task Force Implementation Committee: three (3) appointments needed.
 - b. Beach and Dune Task Force: four (4) appointments needed.
 - c. Convention and Visitors Authority Board: six (6) appointments needed.
 - *Full Service Hotel Industry* – two (2) appointments needed
 - *Limited Service Hotel Industry* – one (1) appointment needed.
 - *Condominium Industry* – one (1) appointment needed.
 - *Tourism Related Industry* (new) – one (1) appointment needed (must be a resident of South Padre Island).
 - *Citizen at Large* – one (1) appointment needed (must be a resident of South Padre Island).
 - d. Development Standards Review Task Force (new): nine (9) appointments needed.
 - e. Economic Development Corporation: three (3) appointments needed
 - f. Keep SPI Beautiful Committee: three (3) appointments needed.
 - g. Parks, Recreation & Beautification Committee (new): seven (7) appointments needed.
 - h. Planning and Zoning Commission: four (4) appointments needed.
 7. Discussion and action on developing procedures and planning of projects for services and infrastructure to South Padre Island residents. (Ridolfi)
 8. Discussion and action on the Texas Chapter of American Shore & Beach Preservation Association (ASBPA) Legislative Agenda. (Clarke)
 9. Discussion and action finalizing the Beachcomber – 2010 Bond Election Special Edition for the Fire and Emergency Services Station Bond Election and guidance on the distribution schedule. (Howell)
 10. Discussion regarding drainage issues on South Padre Island. (Jones)
 11. Discussion and action to amend the Beachfront Construction Certificate and Dune Protection Permit for Robert Fudge that was previously approved located at 7200 Padre Boulevard. (Trevino)

12. Discussion and action on a Beachfront Construction Certificate and Dune Protection Permit for Miguel Torres to construct an ADA beach access ramp located at 6300 Padre Boulevard (Bahia Mar Condominiums). (Trevino)
13. Discussion and action to authorize the City Manager to execute a contract with the General Land Office (GLO) to move forward in the development of Gay Dawn Circle which includes a parking lot with facilities and a walkover. (Trevino)
14. Discussion and action to approve a budget amendment in the amount of \$31,400 for an amendment to the grant that was originally approved January 20, 2010 with the Lower Rio Grande Valley Development Council for a Regional Solid Waste Grants Program in which the City of South Padre Island wishes to purchase two recycling trailers. (Jones/Baldovinos)
15. Adjourn.

WE RESERVE THE RIGHT TO GO INTO EXECUTIVE SESSION REGARDING ANY OF THE ITEMS POSTED ON THIS AGENDA, PURSUANT TO SECTIONS 551.071, CONSULTATION WITH ATTORNEY; 551.072, DELIBERATIONS ABOUT REAL PROPERTY; 551.073, DELIBERATIONS ABOUT GIFTS & DONATIONS; 551.074, PERSONNEL MATTERS; 551.076, DELIBERATIONS ABOUT SECURITY DEVICES; AND/OR 551.086, DISCUSS (A) COMMERCIAL OR FINANCIAL INFORMATION RECEIVED FROM A BUSINESS PROSPECT WITH WHICH THE CITY IS CONDUCTING NEGOTIATIONS, OR (B) FINANCIAL OR OTHER INCENTIVES TO THE BUSINESS PROJECT.

DATED THIS THE 1ST DAY OF OCTOBER 2010

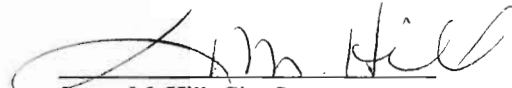
Susan M. Hill, City Secretary

I, THE UNDERSIGNED AUTHORITY, DO HEREBY CERTIFY THAT THE ABOVE NOTICE OF MEETING OF THE GOVERNING BODY OF THE CITY OF SOUTH PADRE ISLAND, TEXAS IS A TRUE AND CORRECT COPY OF SAID NOTICE AND THAT I POSTED A TRUE AND CORRECT COPY OF SAID NOTICE ON THE BULLETIN BOARD AT CITY HALL/MUNICIPAL BUILDING ON **OCTOBER 1, 2010**, AT/OR BEFORE 5:00 P.M. AND REMAINED SO POSTED CONTINUOUSLY FOR AT LEAST 72 HOURS PRECEDING THE SCHEDULED TIME OF SAID MEETING.

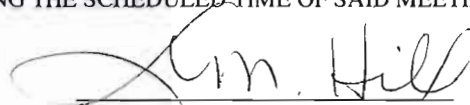
Susan M. Hill, City Secretary

THIS FACILITY IS WHEELCHAIR ACCESSIBLE, AND ACCESSIBLE PARKING SPACES ARE AVAILABLE. REQUESTS FOR ACCOMMODATIONS OR INTERPRETIVE SERVICES MUST BE MADE 48 HOURS PRIOR TO THIS MEETING. PLEASE CONTACT BUILDING OFFICIAL, JAY MITCHIM; ADA DESIGNATED RESPONSIBLE PARTY AT (956) 761-1025.



**CITY COUNCIL MEETING
CITY OF SOUTH PADRE ISLAND
CONSENT AGENDA**

MEETING DATE: October 6, 2010

ITEM DESCRIPTION

NOTE: All matters listed under Consent Agenda are considered routine by the Town of South Padre Island Board of Aldermen and will be enacted by one motion. There will not be separate discussion of these items. If discussion is desired, that item will be removed from the Consent Agenda and considered separately.

Items to be considered are:

- a. Approve minutes of September 9, 2010 Special Meeting, and Workshop and Regular meeting of September 15, 2010. (Hill)
- b. Approve invoices for payment. (Homan)
- c. Approve Lease Agreement for the use of one AutoMark (Voter Assist Terminals) during the November 2, 2010 Special Election. (Hill)
- d. Approve Resolution No. 2010-26 authorizing the submission of three grant applications to the Texas General Land Office ("GLO") Texas Coastal Management Plan ("CMP") and authorizing a designated official to execute all documents and application forms on behalf of the City of south Padre Island. (Trevino)
- e. Approve acceptance of FTA grant in the amount of \$26,593 for the installation of security cameras on WAVE buses. (Vasquez/Arriaga)
- f. Approve Resolution No. 2010-27 supporting the Bikefest Bubba Blackwell Motorcycle Jump on October 8, 2010 and supporting the temporary closure of part of Padre Boulevard (Highway 100) for the event.
- g. Approve Second and Final Reading of Ordinance No. 20-29 amending Chapter 4, Article 1, Section 4-5(A) by providing for the adoption of the 2009 International Residential Code without Section P2904 and modification of the exception in Section R302.2. (Mitchim)
- h. Approve Second and Final Reading of Ordinance No. 10-30 amending Chapter 4, Article V and Chapter 20, Section 20-8.3(C) of the Code of Ordinances, repealing Resolution No. 2009-30 and creating the Development Standards Review Task Force. (Clarke)

RECOMMENDATIONS/COMMENTS

Approve Consent Agenda

COUNCIL ACTION

Motion: _____

Second: _____

Vote: Ayes: _____ **Nays:** _____

Abstentions: _____

**CITY OF SOUTH PADRE ISLAND
CITY COUNCIL WORKSHOP
AGENDA REQUEST FORM**

MEETING DATE: October 6, 2010

NAME/DEPT.: Susan Hill, City Secretary

ITEM

Approve minutes of September 9, 2010 Special Meeting, and Workshop and Regular meeting of September 15, 2010.

ITEM BACKGROUND

RECOMMENDATIONS/COMMENTS

BUDGET/FINANCIAL SUMMARY

COMPREHENSIVE PLAN GOAL

COUNCIL ACTION

Motion: _____

Second: _____

Vote: Ayes: _____ **Nays:** _____

Abstentions: _____

**MINUTES
CITY OF SOUTH PADRE ISLAND
CITY COUNCIL REGULAR MEETING**

WEDNESDAY, SEPTEMBER 15, 2010

I. CALL TO ORDER

The City Council Members of the City of South Padre Island, Texas held a Regular Meeting on Wednesday, September 15, 2010 at the Municipal Complex Building, 2nd Floor, 4601 Padre Boulevard, South Padre Island, Texas. Mayor Pinkerton called the meeting to order at 5:30 p.m. A full quorum was present: Council Member JoAnn Evans, Sam A. Listi, Rick Ridolfi and Alita Bagley. Absent was Council Member Courtney Hayden.

City staff members present were City Attorney Paul Cunningham, City Manager Joni Clarke, Assistant City Manager Darla Jones, CVB Executive Director Dan Quandt, Fire Chief Burney Baskett, Public Works Director Scott Fry, Finance Director Larry Homan, Police Chief Randy Smith, Transit & Development Director Rick Vasquez, Environmental Health Services Director Victor Baldovinos, Building Official Jay Mitchim and City Secretary Susan Hill.

II. PLEDGE OF ALLEGIANCE

Mayor Pinkerton led the Pledge of Allegiance

III. PUBLIC COMMENTS AND ANNOUNCEMENTS

IV. PRESENTATIONS AND PROCLAMATIONS

Mayor Pinkerton read a proclamation calling the week of September 17 – 23, 2010 as Constitution Week.

V. APPROVE CONSENT AGENDA:

Council Member Evans made a motion, seconded by Council Member Bagley to approve the Consent Agenda. Motion carried unanimously.

- a. **APPROVE MINUTES OF AUGUST 25, 2010 WORKSHOP AND SPECIAL MEETING; AND SEPTEMBER 1, 2010 REGULAR MEETING. (HILL)**
- b. **APPROVE INVOICES FOR PAYMENT. (HOMAN)**

Invoices approved for payment were paid by General Fund checks numbered 117974 through 118116 for a total of \$318,048.76.

- c. **APPROVE TAX COLLECTION AND ADJUSTMENT REPORT FOR AUGUST 2010 BY THE POINT ISABEL INDEPENDENT SCHOOL DISTRICT TAX OFFICE. (HOMAN)**
- d. **APPROVE ACCEPTANCE OF TXDOT FEDERAL GRANT CONTRACT IN THE AMOUNT OF \$252,881. (VASQUEZ/ARRIAGA)**
- e. **APPROVE SECOND AND FINAL READING OF ORDINANCE NO. 10-28 ESTABLISHING THE AD VALOREM AND PERSONAL PROPERTY TAX RATE FOR TAX YEAR 2010, AND SETTING THE ASSESSED VALUATION AT ONE HUNDRED PERCENT (100%) OF THE FAIR MARKET VALUE AND PROVIDING FOR DISCOUNTS IN THE EVENT OF EARLY PAYMENT. (HOMAN)**

A true and correct copy of said Ordinance was placed in the City's Ordinance Book and entitled Ordinance No. 10-28, and, by reference hereto, included in these minutes as if fully set out and spread upon the pages of the Minutes Book.

- f. **APPROVE RESOLUTION NO. 2010-24 SUPPORTING THE TEMPORARY CLOSURE OF THE QUEEN ISABELLA MEMORIAL BRIDGE ON OCTOBER 9, 2010 FOR THE SPI BIKEFEST IRON HORSE SUNSET MEMORIAL PARADE. (QUANDT)**

A true and correct copy of said Resolution was placed in the City's Resolution Book and entitled Resolution No. 2010-24, and, by reference hereto, included in these minutes as if fully set out and spread upon the pages of the Minutes Book.

Note: At this time, with no objections from the Council, Mayor Pinkerton moved Item XIV under Item V

VI. DISCUSSION AND ACTION REGARDING THE SELECTION OF THE AWARD WINNER AND PRESENTATION OF THE 2010 ENVIRONMENTAL EXCELLENCE AWARD. (EVANS)

Council Member Evans made a motion to direct staff to carry out procedures necessary to implement the Environmental Excellence Award nomination and presentation process for 2010. Motion was seconded by Council Member Ridolfi, which carried unanimously.

VII. DISCUSSION AND POSSIBLE ACTION REGARDING A REVIEW OF THE PURPOSE, GOALS, AND OBJECTIVES OF ESTABLISHED CITY OF SOUTH PADRE ISLAND BOARDS, COMMITTEES AND COMMISSIONS AND TO EVALUATE THE REORGANIZATION OF THESE COMMITTEES, CREATION OF NEW COMMITTEES AND/OR POSSIBLE ELIMINATION OF EXISTING COMMITTEES. (CLARKE)

Council Member Evans made a motion to approve First Reading of Ordinance No. 10-30 combining Development Plan Review Board, Form based Code Commission and Padre

Boulevard Revitalization Implementation Committee into the Development Standards Review Task Force. Motion was seconded by Council Member Bagley. Council Member Evans amended her motion, seconded by Council Member Bagley, to increase members of this newly created Task Force to nine (9) instead of seven (7). Motion passed on a 5 to 1 vote, with Council Member Listi casting a nay vote.

Motion was made by Mayor Pinkerton to approve a Resolution combining Beach and Dune Task Force with the Bay Area Implementation Task Force to create a Beach and Bay Task Force with nine (9) members instead of seven (7). Motion was seconded by Council Member Evans.

After discussion, Mayor Pinkerton and Council Member Evans withdrew their motion and requested that these two Boards meet with each other to determine if such a merger would be feasible.

Council Member Ridolfi made a motion, seconded by Council Member Evans to approve Resolution No. 2010-25 which creates a Parks, Recreation & Beautification Committee. Motion carried unanimously.

The City Council unanimously decided to eliminate the Food Services Appeals Board with the City Council assuming the responsibility should a variance request occur.

The Council decided not to take action on Keep SPI Beautiful Committee at this time, although it was suggested that perhaps it could become a standalone 501c(3) organization or; act as a subcommittee under the Parks and Recreation Committee.

VIII. DISCUSSION AND ACTION CONCERNING AMENDING RESOLUTION NO. 815 WHICH CREATED THE CONVENTION AND VISITORS AUTHORITY BOARD BY ADDING ONE ADDITIONAL TOURISM-RELATED INDUSTRY REPRESENTATIVE, AMENDING THE SITTING CHAIR OF THE SOUTH PADRE ISLAND CHAMBER OF COMMERCE TO SAY “OR THE CHAIR’S DESIGNEE” AND REMOVE THE CITY MANAGER OF SOUTH PADRE ISLAND FROM THE CVA BOARD. (QUANDT)

Council Member Ridolfi made a motion, seconded by Council Member Bagley to amend Resolution No. 815 with the following:

- a. add one (1) additional tourism-related industry representative to the Convention and Visitors Authority Board. This representative must be a resident of South Padre Island.
- b. the Citizen at large position must also be a resident of South Padre Island.
- c. amend the sitting chair of the South Padre Island Chamber of Commerce to say “or the Chair’s designee”. Designee to serve in one (1) year increments.
- d. to amend the sitting chair of the City Manager of South Padre Island to say “or the City Manager’s designee”. Designee to serve in one (1) year increments.

Motion carried unanimously.

IX. DISCUSSION AND ACTION REGARDING AN INFORMATIONAL SHEET ON THE FIRE STATION PROPOSAL THAT WILL BE DISTRIBUTED TO REGISTERED VOTERS PRIOR TO THE NOVEMBER 2, 2010 SPECIAL ELECTION. (HOWELL)

Council Members gave direction as to additional information and changes they would like to see and asked that it be brought back at the October 6th meeting.

X. PRESENTATION, DISCUSSION AND ACTION REGARDING A PLASTIC BAG REDUCTION PROGRAM. (BALDOVINOS)

After some discussion, the Council asked that an ordinance be drafted requesting voluntary participation with a mandatory compliance date set and be brought back for Council consideration.

XI. DISCUSSION AND ACTION REGARDING THE FIRST READING OF ORDINANCE 10-29 WHICH AMENDS CHAPTER 4, ARTICLE I, SECTION 4-5(A) BY PROVIDING FOR THE ADOPTION OF THE 2009 INTERNATIONAL RESIDENTIAL CODE WITHOUT SECTION P2904 AND MODIFICATION OF THE EXCEPTION IN SECTION R302.2. (MITCHIM)

Council Member Listi made a motion to approve the First Reading of Ordinance No. 10-29. Motion seconded by Council Member Ridolfi. Motion carried unanimously.

XII. DISCUSSION AND ACTION TO ENTER INTO A MULTIPLE USE AGREEMENT WITH TXDOT FOR USE OF TXDOT PROPERTY TO DEVELOP A PARK-AND-RIDE, WAVE ADMINISTRATIVE OFFICES AND LEASE SPACE FOR A VISITOR INFORMATION CENTER. (VASQUEZ/ARRIAGA)

Council Member Evans made a motion, seconded by Council Member Listi to enter into a multiple use agreement with TxDOT for use of TxDOT Property to develop a Park-and-ride, along with administrative offices and information center. Motion carried unanimously.

XIII. DISCUSSION AND ACTION TO AUTHORIZE THE WAVE TO USE TXDOT FUNDS TO ENTER INTO A PROFESSIONAL SERVICES AGREEMENT WITH COLLECTIVE STRENGTH, INC., IN THE AMOUNT OF \$30,000 TO PREPARE FEASIBILITY STUDIES REQUIRED BY THE FEDERAL TRANSIT ADMINISTRATION (FTA) TO BE ELIGIBLE FOR CONSIDERATION OF FTA FUNDING FOR A PARK-AND-RIDE FACILITY, WAVE ADMINISTRATIVE OFFICES AND LEASE SPACE FOR A VISITOR CENTER. (VASQUEZ/ARRIAGA)

Council Member Evans made a motion to approve authorization to use TxDOT funds to enter into a professional services agreement with Collective Strength Inc. in the amount

of \$30,000. Motion was seconded by Council Member Bagley, which carried unanimously.

XIV. DISCUSSION AND ACTION TO APPROVE A THREE (3) YEAR LEASE AGREEMENT OF EIGHT (8) WATCH GUARD DIGITAL IN CAR VIDEO 4RE IN CAMERA SYSTEMS WITH SOFTWARE, STORAGE, ANCILLARY EQUIPMENT AND WARRANTY FROM GOVERNMENT CAPITAL CORPORATION. (SMITH)

Note: This item was moved under Item V

Council Member Ridolfi made a motion, seconded by Council Member Listi to approve the three year lease agreement with Government Capital Corporation and authorized the City Manager to execute the lease documents and all related papers. Motion passed unanimously.

XV. DISCUSSION AND ACTION TO APPROVE BUDGET INCREASE REQUEST IN THE AMOUNT OF \$25,000 NEEDED FOR FUELS AND LUBRICANTS LINE ITEM IN THE GENERAL FUND 2009/10 BUDGET. (HOMAN)

Council Member Ridolfi made a motion to approve the budget increase of \$25,000 for fuels and lubricants. Motion was seconded by Council Member Evans, which carried unanimously.

XVI. ADJOURN.

There being no further business, Mayor Pinkerton adjourned the meeting at 7:28 p.m.

Susan M. Hill, City Secretary

APPROVED

Robert N. Pinkerton, Jr., Mayor

**CITY OF SOUTH PADRE ISLAND
CITY COUNCIL WORKSHOP
AGENDA REQUEST FORM**

MEETING DATE: October 6, 2010

NAME/DEPT.: Larry Homan, Finance Director

ITEM

Approve invoices for payment by General Fund checks numbered 118117 through 118467 for a total of \$623,944.58.

ITEM BACKGROUND

RECOMMENDATIONS/COMMENTS

BUDGET/FINANCIAL SUMMARY

COMPREHENSIVE PLAN GOAL

COUNCIL ACTION

Motion: _____

Second: _____

Vote: Ayes: _____ **Nays:** _____

Abstentions: _____

PKET: 06880 Regular Payments-SMALL AP9-17-

IDOR SET: 01

ID : 01 GENERAL FUND

DEPARTMENT: N/A NON-DEPARTMENTAL

BANK: OPER

BUDGET TO USE: CB-CURRENT BUDGET

IDOR	NAME	ITEM #	G/L	ACCOUNT NAME	DESCRIPTION	CHECK#	AMOUNT
-001290	AMERICAN FAMILY LIFE						
		I-839023	01	-2463	AMERICAN FAMI SEPT.2010 EMPLOYEE PREMIUMS	118126	35.18
-001297	AMERICAN FUNDS						
		I-91610	01	-2485	AMERICAN GENE EMPLOYEE SALARY ALLOC 9/15/10	118127	83.08
-002434	CINDY BOUDLOCHE, TRUSTE						
		I-DW5201009132723	01	-2469	DEBTORS WAGE A/N 07-10758-B-13	118131	662.30
		I-DW9201009132723	01	-2469	DEBTORS WAGE CASE NO 10-10137-B-13	118132	490.38
-003107	VICTOR CARRANZA						
		I-91410	01	-2461	BLUE CROSS ME TML INSURANCE REIMBURSEMENT	118135	227.04
-003185	OFFICE OF THE ATTY GENL						
		I-C09201009132723	01	-2473	CHILD SUPPORT A/N 0010486563	118137	212.31
		I-C10201009132723	01	-2473	CHILD SUPPORT A/N 2004094864B	118138	282.92
		I-C14201009132723	01	-2473	CHILD SUPPORT A/N N002589726	118139	100.00
		I-C24201009132723	01	-2473	CHILD SUPPORT A/N 0011488748	118140	462.18
		I-C31201009132723	01	-2473	CHILD SUPPORT A/N 0011545222	118141	161.54
		I-C32201009132723	01	-2473	CHILD SUPPORT A/N 2007031654D	118142	338.35
		I-C34201009132723	01	-2473	CHILD SUPPORT A/N 0009255855	118143	77.08
		I-C37201009132723	01	-2473	CHILD SUPPORT A/N 2008-10-5941-D	118144	492.46
		I-C47201009132723	01	-2473	CHILD SUPPORT CASE # 0009943810	118145	35.49
		I-C48201009132723	01	-2473	CHILD SUPPORT NO. 2008-08-4758-E	118146	383.08
		I-C49201009132723	01	-2473	CHILD SUPPORT 0009648707	118147	165.69
		I-C50201009132723	01	-2473	CHILD SUPPORT AG CASE #0011346896	118148	634.62
-006133	FORT DEARBORN LIFE INS						
		I-91710	01	-2465	VTL LIFE INSU EMPLOYEE PREMIUMS - VTL	118158	234.21
-006163	AMERICAN GENERAL LIFE I						
		I-91610	01	-2485	AMERICAN GENE EMPLOYEE SALARY ALLOC9/10/10	118159	528.78
-007001	ANA GARZA						
		I-C04201009132723	01	-2473	CHILD SUPPORT A/N 2003-03-1480-B	118160	194.88
-009097	INTERNAL REVENUE SERVIC						
		I-IR6201009132723	01	-2459	IRS LEVY A/N XXX-XX-1603	118169	383.00
-012108	HERMELINDA LONGORIA						
		I-C16201009132723	01	-2473	CHILD SUPPORT A/N 2002031289D	118180	146.77
-016670	PRE-PAID LEGAL SVCS INC						
		I-91010	01	-2476	PREPAID LEGAL SEPT 2010 EMPLOYEE PREMUIMS	118189	14.95
-016686	PUTNAM INVESTMENTS						
		I-91610	01	-2485	AMERICAN GENE EMPLOYEE SALARY ALLOC 9/10/10	118190	62.15
-019222	S.P.I. FIREFIGHTERS ASS						

PACKET: 06880 Regular Payments-SMALL AP9-17-

VENDOR SET: 01

FUND : 01 GENERAL FUND

DEPARTMENT: N/A NON-DEPARTMENTAL

BANK: OPER

BUDGET TO USE: CB-CURRENT BUDGET

VENDOR	NAME	ITEM #	G/L ACCOUNT NAME	DESCRIPTION	CHECK#	AMOUNT
01-019222	S.P.I. FIREFIGHTERS ASS		continued			
		I-091610	01 -2472	FIREFIGHTERS ASSOCIATION DUES 9/15/10	118195	233.00
01-019327	SOUTH PADRE ISLAND PROF					
		I-91610	01 -2487	POLICE DEPT A ASSOCIATION DUES 9/15/10	118196	300.00
01-019997	TG					
		I-DX1201009132723	01 -2469	DEBTORS WAGE CS239406800	118204	150.74
01-020100	T.M.R.S.					
		I-91510	01 -2470	T.M.R.S. AUGUST 2010 CONTRIBUTIONS	118117	31,929.32
01-020615	TOWN OF SOUTH PADRE ISL					
		I-91610	01 -2479	EMPLOYEE ACTI ASSOCIATION DUES 9/15/10	118208	131.00
01-021109	UNITED WAY OF S. CAMERO					
		I-91510	01 -2468	UNITED WAY ASSOCIATION DUES 9/16/10	118213	228.50
01-023200	MICHELLE WILBURN					
		I-C21201009132723	01 -2473	CHILD SUPPORT A/N 0011549506	118217	146.31
				DEPARTMENT NON-DEPARTMENTAL	TOTAL:	39,527.31

PACKET: 06880 Regular Payments-SMALL AP9-17-

VENDOR SET: 01

FUND : 01 GENERAL FUND

DEPARTMENT: 512 CITY ADMINISTRATION

BANK: OPER

BUDGET TO USE: CB-CURRENT BUDGET

VENDOR	NAME	ITEM #	G/L ACCOUNT NAME	DESCRIPTION	CHECK#	AMOUNT	
=====							
01-018135	RELIABLE OFFICE SUPPLIE						
		I-BWQ50400	01 -512-0101	OFFICE SUPPLI Office Supplies	118192	124.12	
		I-BWQ50401	01 -512-0101	OFFICE SUPPLI Office Supplies	118192	102.93	
		I-BWW43800	01 -512-0101	OFFICE SUPPLI MISC.OFFICE SUPPLIES - ADM	118192	143.49	
		I-BWW43801	01 -512-0101	OFFICE SUPPLI 1PK BIC PRO PLUS GEL PENS	118192	6.95	
01-019641	STAPLES CREDIT PLAN						
		I-3139052193-000001	01 -512-0101	OFFICE SUPPLI WALLWORKS	118202	29.99	
		I-3139057243-000001	01 -512-0101	OFFICE SUPPLI 3 DZ PROJECT JACKETS	118202	32.97	
01-020100	T.M.R.S.						
		I-91510	01 -512-0080	TMRS AUGUST 2010 CONTRIBUTIONS	118117	2,889.51	
					DEPARTMENT 512 CITY ADMINISTRATION	TOTAL:	3,329.96

PACKET: 06880 Regular Payments-SMALL AP9-17-

VENDOR SET: 01

FUND : 01 GENERAL FUND

DEPARTMENT: 513 FINANCE DEPARTMENT

BANK: OPER

BUDGET TO USE: CB-CURRENT BUDGET

VENDOR	NAME	ITEM #	G/L ACCOUNT NAME	DESCRIPTION	CHECK#	AMOUNT
01-003248	DOLLY CASTILLO	I-90910	01 -513-0130	WEARING APPAR PURCHASE REIMBURSEMENT	118150	27.05
01-003410	CHAMBER OF COMMERCE - S	I-6419	01 -513-0102	LOCAL MEETING QTRLY LUNCHEON:L.HOMAN	118151	18.00
01-015010	OFFICE DEPOT	I-4131	01 -513-0101	OFFICE SUPPLI MISC.OFFICE SUPPLIES	118185	58.36
01-020100	T.M.R.S.	I-91510	01 -513-0080	TMRS AUGUST 2010 CONTRIBUTIONS	118117	2,386.22
DEPARTMENT 513 FINANCE DEPARTMENT					TOTAL:	2,489.63

PACKET: 06880 Regular Payments-SMALL AP9-17-

VENDOR SET: 01

FUND : 01 GENERAL FUND

DEPARTMENT: 514 PLANNING DEPARTMENT

BANK: OPER

BUDGET TO USE: CB-CURRENT BUDGET

VENDOR	NAME	ITEM #	G/L ACCOUNT NAME	DESCRIPTION	CHECK#	AMOUNT	
=====							
01-016600	PT ISABEL/SO PADRE PRES						
		I-80510	01 -514-0540	ADVERTISING DISPLAY AD:CAPITAL IMPROV PLAN	118188	68.78	
		I-82310	01 -514-0540	ADVERTISING DISPLAY AD:PUBLIC HEARING	118188	78.60	
		I-83010	01 -514-0540	ADVERTISING DISPLAY AD:PUBLIC HEARING	118188	91.70	
01-020100	T.M.R.S.						
		I-91510	01 -514-0080	TMRS AUGUST 2010 CONTRIBUTIONS	118117	1,083.53	
					DEPARTMENT 514 PLANNING DEPARTMENT	TOTAL:	1,322.61

PACKET: 06880 Regular Payments-SMALL AP9-17-

VENDOR SET: 01

FUND : 01 GENERAL FUND

DEPARTMENT: 515 TECHNOLOGY DEPARTMENT

BANK: OPER

BUDGET TO USE: CB-CURRENT BUDGET

VENDOR	NAME	ITEM #	G/L ACCOUNT NAME	DESCRIPTION	CHECK#	AMOUNT
01-001161	AT&T	I-91910	01 -515-0415	SERVICE CONTR SUBSCRIBER/ROUTER ID 3092512	118125	384.03
01-015029	ORBIT BROADBAND	I-11112	01 -515-0415	SERVICE CONTR WEB HOSTING SPIPD.NET	118186	24.95
01-016110	PADRE ISLAND'S ACE HARD	I-061444	01 -515-0150	MINOR TOOLS & COUPLER, WIRE, SWITCH BOX	118187	37.20
		I-061862	01 -515-0150	MINOR TOOLS & WIRE,CONNECTOR	118187	20.97
01-019404	SPRINT	I-463528814-033	01 -515-0501	COMMUNICATION SPRINTCELL PHONE BILL 8/20/10	118197	2,216.53
01-019520	AT&T	I-90310	01 -515-0415	SERVICE CONTR PHONE BILL DATED 9/03/10	118199	759.54
01-020100	T.M.R.S.	I-91510	01 -515-0080	TMRS AUGUST 2010 CONTRIBUTIONS	118117	1,541.23
01-020185	TIME WARNER CABLE	I-81810	01 -515-0415	SERVICE CONTR SERVICE 8/28/10 - 9/27/10	118206	304.07
DEPARTMENT 515 TECHNOLOGY DEPARTMENT					TOTAL:	5,288.52

PACKET: 06880 Regular Payments-SMALL AP9-17-

VENDOR SET: 01

FUND : 01 GENERAL FUND

DEPARTMENT: 516 HUMAN RESOURCES

BANK: OPER

BUDGET TO USE: CB-CURRENT BUDGET

VENDOR	NAME	ITEM #	G/L ACCOUNT NAME	DESCRIPTION	CHECK#	AMOUNT
01-020100	T.M.R.S.	I-91510	01 -516-0080	TMRS	AUGUST 2010 CONTRIBUTIONS	118117 815.94
DEPARTMENT 516 HUMAN RESOURCES					TOTAL:	815.94

PACKET: 06880 Regular Payments-SMALL AP9-17-

VENDOR SET: 01

FUND : 01 GENERAL FUND

DEPARTMENT: 520 MUNICIPAL COURT

BANK: OPER

BUDGET TO USE: CB-CURRENT BUDGET

VENDOR	NAME	ITEM #	G/L ACCOUNT NAME	DESCRIPTION	CHECK#	AMOUNT
01-008265	PAUL HEMPHILL					
		I-91410	01 -520-0530	PROFESSIONAL SERVICES RENDERED AUG 2010	118168	250.00
01-019641	STAPLES CREDIT PLAN					
		I-3139040342-000001	01 -520-0101	OFFICE SUPPLI HEAVY STAPLER & SHREDDER	118202	116.98
		I-3139040342-000001	01 -520-0150	MINOR TOOLS & HEAVY STAPLER & SHREDDER	118202	116.00
01-020100	T.M.R.S.					
		I-91510	01 -520-0080	TMRS AUGUST 2010 CONTRIBUTIONS	118117	690.02
DEPARTMENT 520 MUNICIPAL COURT					TOTAL:	1,173.00

PACKET: 06880 Regular Payments-SMALL AP9-17-

VENDOR SET: 01

FUND : 01 GENERAL FUND

DEPARTMENT: 521 POLICE DEPARTMENT

BANK: OPER

BUDGET TO USE: CB-CURRENT BUDGET

VENDOR	NAME	ITEM #	G/L ACCOUNT NAME	DESCRIPTION	CHECK#	AMOUNT
01-019641	STAPLES	CREDIT PLAN				
		I-3139051011-00001	01 -521-0101	OFFICE SUPPLI PADS, FOLDERS, ENVELOPES, ETC	118202	148.14
01-020100	T.M.R.S.					
		I-91510	01 -521-0080	TMRS AUGUST 2010 CONTRIBUTIONS	118117	15,496.83
DEPARTMENT 521 POLICE DEPARTMENT					TOTAL:	15,644.97

PACKET: 06880 Regular Payments-SMALL AP9-17-

VENDOR SET: 01

FUND : 01 GENERAL FUND

DEPARTMENT: 522 FIRE DEPARTMENT

BANK: OPER

BUDGET TO USE: CB-CURRENT BUDGET

VENDOR	NAME	ITEM #	G/L	ACCOUNT NAME	DESCRIPTION	CHECK#	AMOUNT
01-001097	ACETYLENE OXYGEN COMPAN						
		I-100114295	01	-522-0114	MEDICAL ACETYLENE/OXYFEN RENTAL	118120	21.74
		I-100143020	01	-522-0114	MEDICAL ACETYLENE/OXYG. RENTAL	118120	21.74
01-003245	CASCO INDUSTRIES INC.						
		I-087766	01	-522-0117	SAFETY SUPPLI NEW FIRE FIGHTING BOOTS	118149	120.00
01-006086	WITMER ASSOCIATES, INC.						
		I-1048547	01	-522-0130	WEARING APPAR REPLACEMENT BOOTS	118156	110.94
01-015010	OFFICE DEPOT						
		I-04012	01	-522-0101	OFFICE SUPPLI MISC. OFFICE SUPPLIES	118185	238.50
		I-4131	01	-522-0101	OFFICE SUPPLI MISC.OFFICE SUPPLIES	118185	45.30
		I-4131	01	-522-0107	BOOKS & PERIO MISC.OFFICE SUPPLIES	118185	24.42
01-018073	RDJ SPECIALIST INC.						
		I-004562	01	-522-0150	MINOR TOOLS & TATOOES - KIDS	118191	265.81
01-020100	T.M.R.S.						
		I-91510	01	-522-0080	TMRS AUGUST 2010 CONTRIBUTIONS	118117	10,335.41
01-023046	GREGORY NEIL WATERS						
		I-90310	01	-522-0130	WEARING APPAR PURCHASE REIMBURSEMENT	118215	68.00
DEPARTMENT 522 FIRE DEPARTMENT						TOTAL:	11,251.86

PACKET: 06880 Regular Payments-SMALL AP9-17-

VENDOR SET: 01

FUND : 01 GENERAL FUND

DEPARTMENT: 532 CODE ENFORCEMENT

BANK: OPER

BUDGET TO USE: CB-CURRENT BUDGET

VENDOR	NAME	ITEM #	G/L ACCOUNT NAME	DESCRIPTION	CHECK#	AMOUNT
01-019599	EDNA STAMBAUGH					
		I-61410	01 -532-0513	TRAINING EXPE MISC. REIMBURSEMENT	118200	25.00
		I-61410	01 -532-0550	TRAVEL EXPENS MISC. REIMBURSEMENT	118200	9.91
01-020100	T.M.R.S.					
		I-91510	01 -532-0080	TMRS AUGUST 2010 CONTRIBUTIONS	118117	2,079.97
DEPARTMENT 532 CODE ENFORCEMENT					TOTAL:	2,114.88

PACKET: 06880 Regular Payments-SMALL AP9-17-

VENDOR SET: 01

FUND : 01 GENERAL FUND

DEPARTMENT: 540 FLEET MANAGEMENT

BANK: OPER

BUDGET TO USE: CB-CURRENT BUDGET

VENDOR	NAME	ITEM #	G/L ACCOUNT NAME	DESCRIPTION	CHECK#	AMOUNT
=====						
01-001123	ADVANCE AUTO PARTS					
		C-1592	01 -540-0420-03	REPAIRS & MAI RADIATOR HOSE/ANTIFREEZE RT	118121	110.53-
		C-9233	01 -540-0420-03	REPAIRS & MAI 1-BODY GASKET THROTL RETU	118121	3.58-
		I-0884	01 -540-0420-02	REPAIRS & MAI BRAKE CALIPERS	118121	149.00
		I-0978	01 -540-0420-04	REPAIRS & MAI 12 QTS EA.5W20, 5W30 OIL CODE	118121	47.76
		I-0979	01 -540-0420-03	REPAIRS & MAI 12QTS EA 5W20,5W30	118121	47.76
		I-1455	01 -540-0420-03	REPAIRS & MAI OIL ABSORB WAHSEY FLUID	118121	49.72
		I-1456	01 -540-0420-01	REPAIRS & MAI 6 GAL. WASHER FLUID	118121	11.94
		I-1589	01 -540-0420-04	REPAIRS & MAI BATTERY, ETC. UNIT CE 81	118121	72.92
		I-1590	01 -540-0420-03	REPAIRS & MAI ANTI FREEZE, RADIATOR HOSE	118121	110.53
		I-1649	01 -540-0420-03	REPAIRS & MAI 1 BODY GASKET THROTTLE	118121	3.58
		I-1668	01 -540-0420-03	REPAIRS & MAI 1-AUDIO HOOK PRBE TSTR	118121	19.99
		I-9139	01 -540-0420-02	REPAIRS & MAI F-4 FD WHEEL BEARING	118121	200.68
01-007006	GT DISTRIBUTORS, INC.					
		I-INV0323558	01 -540-1007	MOTOR VEHICLE C02 C03 AND C04PD	118161	665.39
01-007075	GALLS					
		I-510801032	01 -540-1007	MOTOR VEHICLE C-02 AND C-03 PD	118164	1,075.97
01-016110	PADRE ISLAND'S ACE HARD					
		I-061212	01 -540-0420-03	REPAIRS & MAI SOLDER, GLUE,	118187	8.48
		I-062054	01 -540-0420-03	REPAIRS & MAI 1-AIR QUICK	118187	4.99
		I-063037	01 -540-0420-03	REPAIRS & MAI 5-HARDWARE	118187	7.45
		I-063259	01 -540-0420-03	REPAIRS & MAI AUTO FUSE KITS	118187	12.56
		I-063528	01 -540-0420-03	REPAIRS & MAI 2-HOSE CLAMPS	118187	1.99
		I-064868	01 -540-0420-03	REPAIRS & MAI 1-BLACKSMITH HAMMER	118187	19.99
01-020100	T.M.R.S.					
		I-91510	01 -540-0080	TMRS AUGUST 2010 CONTRIBUTIONS	118117	668.98
					TOTAL:	3,065.57

PACKET: 06880 Regular Payments-SMALL AP9-17-

VENDOR SET: 01

FUND : 01 GENERAL FUND

DEPARTMENT: 541 BUILDING MAINTENANCE

BANK: OPER

BUDGET TO USE: CB-CURRENT BUDGET

VENDOR	NAME	ITEM #	G/L ACCOUNT NAME	DESCRIPTION	CHECK#	AMOUNT
01-001129	A & W OFFICE SUPPLY INC	I-434803-0	01 -541-0101	OFFICE SUPPLI FASTENERS,BATTERIES	118123	33.27
01-013111	MARINE ELECTRIC SVC INC	I-14646	01 -541-0410	MACHINERY & E OLD CITY HALL	118181	305.00
01-020100	T.M.R.S.	I-91510	01 -541-0080	TMRS AUGUST 2010 CONTRIBUTIONS	118117	739.26
DEPARTMENT 541 BUILDING MAINTENANCE					TOTAL:	1,077.53

PACKET: 06880 Regular Payments-SMALL AP9-17-

VENDOR SET: 01

FUND : 01 GENERAL FUND

DEPARTMENT: 542 INSPECTIONS DIVISION

BANK: OPER

BUDGET TO USE: CB-CURRENT BUDGET

VENDOR	NAME	ITEM #	G/L ACCOUNT NAME	DESCRIPTION	CHECK#	AMOUNT
01-020100	T.M.R.S.	I-91510	01 -542-0080	TMRS	AUGUST 2010 CONTRIBUTIONS	118117 1,207.77
					DEPARTMENT 542 INSPECTIONS DIVISION	TOTAL: 1,207.77

PACKET: 06880 Regular Payments-SMALL AP9-17-

VENDOR SET: 01

FUND : 01 GENERAL FUND

DEPARTMENT: 543 PUBLIC WORKS DEPARTMENT

BANK: OPER

BUDGET TO USE: CB-CURRENT BUDGET

VENDOR	NAME	ITEM #	G/L ACCOUNT NAME	DESCRIPTION	CHECK#	AMOUNT
01-016110	PADRE ISLAND'S ACE HARD					
		I-061970	01 -543-0150	MINOR TOOLS & 2-WIRE TIE RE BAR	118187	11.98
		I-063029	01 -543-0150	MINOR TOOLS & ANT/ROACH SPRAY	118187	7.28
01-020014	TX BOARD OF PROF ENGINE					
		I-91010	01 -543-0530	PROFESSIONAL RENEWAL FEE: SCOTT FRY	118205	235.00
01-020100	T.M.R.S.					
		I-91510	01 -543-0080	TMRS AUGUST 2010 CONTRIBUTIONS	118117	5,295.45
DEPARTMENT 543 PUBLIC WORKS DEPARTMENT TOTAL:						5,549.71

PACKET: 06880 Regular Payments-SMALL AP9-17-

VENDOR SET: 01

FUND : 01 GENERAL FUND

DEPARTMENT: 570 GENERAL SERVICES

BANK: OPER

BUDGET TO USE: CB-CURRENT BUDGET

VENDOR	NAME	ITEM #	G/L ACCOUNT NAME	DESCRIPTION	CHECK#	AMOUNT	
01-002805	ALLIED WASTE SERVICES #						
		I-0863000401470	01 -570-0581	WATER, SEWER, 108 W.RETAMA	118134	2,268.84	
01-009159	IKON OFFICE SOLUTIONS						
		I-83129029	01 -570-0510	RENTAL OF EQU COPIER LEASE FY2009-10	118170	243.51	
01-012071	LAGUNA MDRE WTR DIST NO						
		I-201009152725	01 -570-0581	WATER, SEWER, 80 FT. E. NEW CAUSEWAY	118173	271.48	
		I-201009152728	01 -570-0581	WATER, SEWER, 1313PADRE BLVD	118173	12.15	
		I-201009152729	01 -570-0581	WATER, SEWER, 911 PADRE BLVD MDN	118173	10.80	
		I-201009152730	01 -570-0581	WATER, SEWER, 1201 PADRE BLVD MDN	118173	10.80	
		I-201009152731	01 -570-0581	WATER, SEWER, 1612 PADRE BLVD MDN	118173	12.82	
		I-201009152732	01 -570-0581	WATER, SEWER, 2000 PADRE BLVD MDN	118173	12.15	
		I-201009152733	01 -570-0581	WATER, SEWER, 2412 PADRE BLVD MDN	118173	15.96	
		I-201009152734	01 -570-0581	WATER, SEWER, 2700 PADRE BLVD MDN	118173	11.02	
		I-201009152735	01 -570-0581	WATER, SEWER, 3000 PADRE BLVD MDN	118173	10.80	
		I-201009152736	01 -570-0581	WATER, SEWER, CRN PADRE @ TARPON MDN	118173	19.55	
		I-201009152737	01 -570-0581	WATER, SEWER, 1800 GULF BLVD	118173	205.73	
		I-201009152738	01 -570-0581	WATER, SEWER, 2712 PADRE BLVD	118173	10.80	
		I-201009152739	01 -570-0581	WATER, SEWER, 3420 GULF BLVD - ACCESS11	118173	186.00	
		I-201009152740	01 -570-0581	WATER, SEWER, 104 W.RETAMA ST.	118173	21.86	
		I-201009152741	01 -570-0581	WATER, SEWER, 110 E.MORNINGSIDE DR	118173	72.03	
		I-201009152742	01 -570-0581	WATER, SEWER, 6100 PADRE BLVD	118173	14.95	
		I-201009152744	01 -570-0581	WATER, SEWER, 108 W.HUISACHE ST.	118173	28.91	
		I-201009152745	01 -570-0581	WATER, SEWER, 4380 GULF BLVD	118173	10.80	
		I-201009152746	01 -570-0581	WATER, SEWER, 4501 PADRE BLVD	118173	160.09	
		I-201009152747	01 -570-0581	WATER, SEWER, 4501 PADRE BLVD	118173	52.20	
		I-201009152748	01 -570-0581	WATER, SEWER, 4501PADRE BLVD	118173	67.01	
		I-201009152749	01 -570-0581	WATER, SEWER, 4501 PADRE BLVD(19-6119-01)	118173	171.97	
		I-201009152750	01 -570-0581	WATER, SEWER, 4601 PADRE BLVD	118173	50.25	
		I-201009152751	01 -570-0581	WATER, SEWER, 4601 PADRE BLVD	118173	807.76	
		I-201009152752	01 -570-0581	WATER, SEWER, LAGUNA & VENUS	118173	72.03	
01-019520	AT&T						
		I-90310	01 -570-0501	COMMUNICATION PHONE BILL DATED 9/03/10	118199	1,940.03	
					DEPARTMENT 570 GENERAL SERVICES	TOTAL:	6,772.30
					FUND 01 GENERAL FUND	TOTAL:	100,631.56

PACKET: 06880 Regular Payments-SMALL AP9-17-

VENDOR SET: 01

FUND : 02 HOTEL/MOTEL TAX FUND

DEPARTMENT: 590 VISITORS BUREAU

BANK: OPER

BUDGET TO USE: CB-CURRENT BUDGET

VENDOR	NAME	ITEM #	G/L ACCOUNT NAME	DESCRIPTION	CHECK#	AMOUNT
01-012071	LAGUNA MDRE WTR DIST NO					
		I-201009152726	02 -590-0581	WATER,SEWER & 600 PADRE BLVD	118173	101.52
		I-201009152727	02 -590-0581	WATER,SEWER & 600 PADRE BLVD (16-4057-01)	118173	76.97
01-019404	SPRINT					
		I-463528814-033	02 -590-0501	COMMUNICATION SPRINTCELL PHONE BILL 8/20/10	118197	1.23-
01-019520	AT&T					
		I-90310	02 -590-0501	COMMUNICATION PHONE BILL DATED 9/03/10	118199	618.75
01-020100	T.M.R.S.					
		I-91510	02 -590-0080	TMRS AUGUST 2010 CONTRIBUTIONS	118117	612.46
01-020185	TIME WARNER CABLE					
		I-090410	02 -590-0501	COMMUNICATION BROARDBAND INTERNET SERV.	118206	249.90
01-021095	UNITED PARCEL SERVICE					
		I-0000648239350	02 -590-0108	POSTAGE MISC.SHIPPING CHARGES	118212	31.20
		I-0000648239360	02 -590-0108	POSTAGE MISC.SHIPPING CHRGES	118212	85.15
DEPARTMENT 590 VISITORS BUREAU					TOTAL:	1,774.72

PACKET: 06880 Regular Payments-SMALL AP9-17-

VENDOR SET: 01

FUND : 02 HOTEL/MOTEL TAX FUND

DEPARTMENT: 592 SALES & MARKETING

BANK: OPER

BUDGET TO USE: CB-CURRENT BUDGET

VENDOR	NAME	ITEM #	G/L ACCOUNT NAME	DESCRIPTION	CHECK#	AMOUNT
01-001020	DEEONDA AHADI	I-81310	02 -592-0550	TRAVEL EXPENS MISC. REIMBURSEMENT	118119	47.60
01-00612	FEDEX	I-5-801-63418	02 -592-0108	POSTAGE MISC.SHIPPING CHARGES	118157	191.73
01-019404	SPRINT	I-463528814-033	02 -592-0501	COMMUNICATION SPRINTCELL PHONE BILL 8/20/10	118197	258.81
01-019520	AT&T	I-90310	02 -592-0501	COMMUNICATION PHONE BILL DATED 9/03/10	118199	567.18
01-020100	T.M.R.S.	I-91510	02 -592-0080	TMRS AUGUST 2010 CONTRIBUTIONS	118117	4,367.07
01-020185	TIME WARNER CABLE	I-90410	02 -592-0501	COMMUNICATION 2921 S.EXPWY	118206	919.90
		I-90410-1	02 -592-0501	COMMUNICATION 7355 PADRE BLVD	118206	494.29
DEPARTMENT 592 SALES & MARKETING					TOTAL:	6,846.58

PACKET: 06880 Regular Payments-SMALL AP9-17-

VENDOR SET: 01

FUND : 02 HOTEL/MOTEL TAX FUND

DEPARTMENT: 593 EVENTS MARKETING

BANK: OPER

BUDGET TO USE: CB-CURRENT BUDGET

VENDOR	NAME	ITEM #	G/L ACCOUNT NAME	DESCRIPTION	CHECK#	AMOUNT			
01-003697 A	CLEAN PORTOCO BRWNSVL								
		I-01-128998-01	02 -593-7010	HOSTING COSTS PORTABLE TOILETS-JULY 4TH	118152	1,120.00			
01-020100	T.M.R.S.								
		I-91510	02 -593-0080	TMRS AUGUST 2010 CONTRIBUTIONS	118117	431.12			
					DEPARTMENT 593	EVENTS MARKETING	TOTAL:	1,551.12	
					FUND	02	HOTEL/MOTEL TAX FUND	TOTAL:	10,172.42

PACKET: 06880 Regular Payments-SMALL AP9-17-

VENDOR SET: 01

FUND : 06 CONVENTION CENTER FUND

DEPARTMENT: 565 CONVENTION CENTER OPER

BANK: OPER

BUDGET TO USE: CB-CURRENT BUDGET

VENDOR	NAME	ITEM #	G/L ACCOUNT NAME	DESCRIPTION	CHECK#	AMOUNT
01-001142	AT&T GLOBAL SERVICES, I	I-SB617394	06 -565-0415	SERVICE CONTR MAINTENANCE PER CONTRACT	118124	189.96
01-003704	CAMERON COUNTY	I-91610	06 -565-0560	CAMERON COUNT LEASE PYMT: CONVENTION CTR	118153	27,000.00
01-004405	ESCAPE INTO AQUARIUMS	I-90910	06 -565-0415	SERVICE CONTR AQUARIUM MAINTENANCE	118155	225.00
		I-90910-1	06 -565-0415	SERVICE CONTR AQUARIUM MAINTENANCE	118155	225.00
01-007029	GE CAPITAL	I-54478676	06 -565-0510	RENTAL OF EQU TAXES	118162	75.00
01-012071	LAGUNA MDRE WTR DIST NO	I-201009152743	06 -565-0581	WATER, SEWER 7355 PADRE BLVD	118173	2,155.46
01-013297	MOBILE MINI, INC	I-122095526	06 -565-0510	RENTAL OF EQU MOBILE OFFICE RENTAL	118182	243.00
01-019404	SPRINT	I-463528814-033	06 -565-0501	COMMUNICATION SPRINTCELL PHONE BILL 8/20/10	118197	104.40
01-019520	AT&T	I-90310	06 -565-0501	COMMUNICATION PHONE BILL DATED 9/03/10	118199	1,753.11
01-019645	STRONG AC & REFRIGERATI	I-91410	06 -565-1004	MACHINERY & E 20 TON UNIT	118203	10,500.00
01-020100	T.M.R.S.	I-91510	06 -565-0080	TMRS AUGUST 2010 CONTRIBUTIONS	118117	2,633.95
01-020745	TRANE, A DIVISION OF AM	I-11050283	06 -565-0415	SERVICE CONTR ANNUAL SERVICE CONTRACT	118209	1,497.06
01-020816	TROPI TEX	I-6203	06 -565-0412	LANDSCAPE MAI FERTILIZED	118210	1,475.00
01-020902	SIMPLEXGRINNELL(TYCO)	I-73804558	06 -565-0415	SERVICE CONTR FIRE ALARM, SPRINKLET SYS	118211	2,984.00
					DEPARTMENT 565 CONVENTION CENTER OPER TOTAL:	51,060.94
					FUND 06 CONVENTION CENTER FUND TOTAL:	51,060.94

PACKET: 06880 Regular Payments-SMALL AP9-17-

VENDOR SET: 01

FUND : 22 MUN. COURT SECURITY FUND

DEPARTMENT: 521 ** INVALID DEPT **

BANK: OPER

BUDGET TO USE: CB-CURRENT BUDGET

VENDOR	NAME	ITEM #	G/L ACCOUNT NAME	DESCRIPTION	CHECK#	AMOUNT
01-015010	OFFICE DEPOT					
		I-531996731001	22 -521-0150	MINOR TOOLS A DISPLAY CASE	118185	329.59
					DEPARTMENT 521 ** INVALID DEPT **	TOTAL: 329.59
					FUND 22 MUN. COURT SECURITY FUND	TOTAL: 329.59

PACKET: 06880 Regular Payments-SMALL AP9-17-

VENDOR SET: 01

FUND : 30 TRANSPORTAION GRANT

DEPARTMENT: 591 TRANSPORTATION DEPT

BANK: OPER

BUDGET TO USE: CB-CURRENT BUDGET

VENDOR	NAME	ITEM #	G/L ACCOUNT NAME	DESCRIPTION	CHECK#	AMOUNT
=====						
01-001123	ADVANCE AUTO PARTS					
		I-0887	30 -591-0420	MOTOR VEHICLE 12ARMORALL	118121	60.92
		I-1006	30 -591-0420	MOTOR VEHICLE TIRE FOAM	118121	142.63
		I-1241	30 -591-0420	MOTOR VEHICLE OXYG SENSOR, UNIT #29	118121	149.96
		I-1385	30 -591-0420	MOTOR VEHICLE 24 QTS.5W20 OIL DOT	118121	54.96
01-001359	JESUS ARRIAGA					
		I-91010	30 -591-0513	TRAINING MISC.REIMBURSEMENT	118130	103.72
		I-91010	30 -591-0150	MINOR TOOLS & MISC.REIMBURSEMENT	118130	41.11
01-012071	LAGUNA MDRE WTR DIST NO					
		I-201009152751	30 -591-0581	WTR/SWR/GARBA 4601 PADRE BLVD	118173	115.40
01-019404	SPRINT					
		I-463528814-033	30 -591-0501	COMMUNICATION SPRINTCELL PHONE BILL 8/20/10	118197	202.64
01-019520	AT&T					
		I-90310	30 -591-0501	COMMUNICATION PHONE BILL DATED 9/03/10	118199	277.15
01-020100	T.M.R.S.					
		I-91510	30 -591-0080	TMRS AUGUST 2010 CONTRIBUTIONS	118117	2,167.97
				DEPARTMENT 591 TRANSPORTATION DEPT	TOTAL:	3,316.46

			FUND 30	TRANSPORTAION GRANT	TOTAL:	3,316.46

PACKET: 06880 Regular Payments-SMALL AP9-17-

VENDOR SET: 01

FUND : 60 BEACH MAINTENANCE FUND

DEPARTMENT: 560 BEACH MAINTENANCE

BANK: OPER

BUDGET TO USE: CB-CURRENT BUDGET

VENDOR	NAME	ITEM #	G/L ACCOUNT NAME	DESCRIPTION	CHECK#	AMOUNT
01-007600	GULF COAST PAPER CO. IN					
		I-59342	60 -560-0510	EXCESS BEACH DRUM LINERS	118166	489.00
		I-59343	60 -560-0510	EXCESS BEACH JANITORIAL FOR PUBLIC RR	118166	163.24
01-013396	MORRISON SUPPLY					
		I-55085564	60 -560-0510	EXCESS BEACH 2- PART FOR RESTROOM REPAIR	118183	110.00
01-016110	PADRE ISLAND'S ACE HARD					
		I-063842	60 -560-0150	MINOR TOOLS & 1-50 FT POLY ROPE	118187	4.99
		I-381356	60 -560-0150	MINOR TOOLS & LINK CHAIN	118187	2.99
01-019404	SPRINT					
		I-463528814-033	60 -560-0501	COMMUNICATION SPRINTCELL PHONE BILL 8/20/10	118197	18.53
01-020100	T.M.R.S.					
		I-91510	60 -560-0080	TMRS AUGUST 2010 CONTRIBUTIONS	118117	1,161.27
					DEPARTMENT 560 BEACH MAINTENANCE TOTAL:	1,950.02
					FUND 60 BEACH MAINTENANCE FUND TOTAL:	1,950.02

PACKET: 06880 Regular Payments-SMALL AP9-17-

VENDOR SET: 01

FUND : 80 ECONOMIC DEVELOPMENT CORP

DEPARTMENT: N/A NON-DEPARTMENTAL

BANK: OPER

BUDGET TO USE: CB-CURRENT BUDGET

VENDOR	NAME	ITEM #	G/L ACCOUNT NAME	DESCRIPTION	CHECK#	AMOUNT
01-007044	GEOCENTRAL					
		I-5985891-IN	80 -1401	GIFT SHOP INV EDC/SPIBNC:GIFT SHOP ITEMS	118163	59.23
01-012097	DARLA LAPEYRE					
		I-90910	80 -1101	PETTY CASH EDC: PETTY CASH FUND	118179	600.00
01-019600	STATE COMPTROLLER					
		I-91610	80 -2427	SALES TAX SALES TAX FOR AUGUST 2010	118201	507.21
		I-91610	80 -48042	MISC. REVENUE SALES TAX FOR AUGUST 2010	118201	2.54-
01-023138	WILD REPUBLIC					
		I-SI748093	80 -1401	GIFT SHOP INV EDC/SPIBNC:GIFT SHOP ITEMS	118216	338.20
					DEPARTMENT	
					NON-DEPARTMENTAL	
					TOTAL:	1,502.10

PACKET: 06880 Regular Payments-SMALL AP9-17-

VENDOR SET: 01

FUND : 80 ECONOMIC DEVELOPMENT CORP

DEPARTMENT: 580 EDC

BANK: OPER

BUDGET TO USE: CB-CURRENT BUDGET

VENDOR	NAME	ITEM #	G/L ACCOUNT NAME	DESCRIPTION	CHECK#	AMOUNT
01-000999	AARON ECONOMIC CONSULTI	I-071002	80 -580-0534-006	ECONOMIC ACTI EDC: ECONOMIC INDEX FOR2009	118118	4,000.00
01-001335	AnswerONE, L.L.C.	I-91429	80 -580-0501	COMMUNICATION EDC: VOICE MAIL 8/29-9/25/10	118128	23.95
01-019520	AT&T	I-090310	80 -580-0501	COMMUNICATION EDC:PHONE BILL DATED9/03/10	118198	159.92
01-020100	T.M.R.S.	I-91510	80 -580-0080	TMRS AUGUST 2010 CONTRIBUTIONS	118117	595.16
DEPARTMENT 580 EDC					TOTAL:	4,779.03

PACKET: 06880 Regular Payments-SMALL AP9-17-
 VENDOR SET: 01
 FUND : 80 ECONOMIC DEVELOPMENT CORP
 DEPARTMENT: 581 BIRDING CENTER
 BUDGET TO USE: CB-CURRENT BUDGET

BANK: OPER

VENDOR	NAME	ITEM #	G/L ACCOUNT NAME	DESCRIPTION	CHECK#	AMOUNT
01-001349	ARGUS SECURITY SYSTEMS					
		I-17795457	80 -581-0415	SERVICE CONTR EDC/SPIBNC:FIRE ALARMMONTOR	118129	95.97
01-002805	ALLIED WASTE SERVICES #					
		I-0863000398548	80 -581-0581	WATER, SEWER, EDC:SERVICE @6801 PADRE BLVD	118133	73.99
01-003150	CAMERON COUNTY PARKS &					
		I-90710	80 -581-0415	SERVICE CONTR EDC/SPIBNC:1 MONTH DEPOSIT	118136	396.00
01-004207	DIGITAL OFFICE SYSTEMS					
		I-109781	80 -581-0415	SERVICE CONTR EDC/SPIBNC: COPIER CHARGES	118154	242.39
01-007501	GREEN ELECTRICAL SUPPLY					
		I-880970	80 -581-0590	JANITORIAL EDC/SPIBNC:LAMPSFOR EXHIBIT	118165	181.05
01-008130	WENDY HAUSCHILDT					
		I-90110	80 -581-0415	SERVICE CONTR EDC/SPIBNC:MONTHLY WEB	118167	300.00
01-009662	JONES & COOK STATIONERS					
		I-3139200-0	80 -581-0101	OFFICE SUPPLI EDC/SPIBNC:MISC.OFFICE SUPPLIE	118171	38.28
01-012036	LABOR READY					
		I-90688047	80 -581-0040	PART TIME EMP EDC/SPIBNC:TEMP.HELP GIFT SHP	118172	161.25
01-012071	LAGUNA MDRE WTR DIST NO					
		I-201009152753	80 -581-0581	WATER, SEWER, EDC:6801 PADRE BLVD IRRIG	118173	872.09
		I-201009152754	80 -581-0581	WATER, SEWER, EDC:6801 PADRE BLVD	118173	171.97
		I-201009152755	80 -581-0581	WATER, SEWER, 6801 PADRE BLVD F/L	118173	50.25
01-013404	MOUNTAIN GLACIER, LLC					
		I-103445	80 -581-0101	OFFICE SUPPLI EDCSPIBNC:BOTTLED WATER	118184	8.10
01-016600	PT ISABEL/SO PADRE PRES					
		I-819	80 -581-0540	ADVERTISING EDC/SPIBNC:AD PUBLISHED 8/19	118188	206.33
01-019130	SETTLE & ASSOCIATES, I					
		I-12936	80 -581-0530	PROFESSIONAL EDC/SPIBNC:COMPUTER REPAIR	118193	85.50
01-019520	AT&T					
		I-090310	80 -581-0501	COMMUNICATION EDC:PHONE BILL DATED9/03/10	118198	184.86
01-020100	T.M.R.S.					
		I-91510	80 -581-0080	TMRS AUGUST 2010 CONTRIBUTIONS	118117	0.00
01-020208	TEMP CONTROL, INC.					
		I-16835	80 -581-0415	SERVICE CONTR EDC/BNC:A/C BELT REPLACE	118207	75.00
01-022153	VALLEY SANITARY SUPPLY,					
		I-5583	80 -581-0590	JANITORIAL EDC/SPIBNC:1 CS, BATH TISSUE	118214	35.56

DEPARTMENT 581 BIRDING CENTER TOTAL: 3,178.59

FUND 80 ECONOMIC DEVELOPMENT CORPTOTAL: 9,459.72

PACKET: 06880 Regular Payments-SMALL AP9-17-

VENDOR SET: 01

FUND : 85 BIRDING CENTER CONSTRUCTI

DEPARTMENT: 580 ** INVALID DEPT **

BANK: OPER

BUDGET TO USE: CB-CURRENT BUDGET

VENDOR	NAME	ITEM #	G/L ACCOUNT NAME	DESCRIPTION	CHECK#	AMOUNT
01-019196	SHAMROCK BUILDERS					
		I-81110	85 -580-1001	BUILDINGS & S EDC; INSTALLATION OF DOOR	118194	74.00
				DEPARTMENT 580 ** INVALID DEPT **	TOTAL:	74.00
			FUND 85	BIRDING CENTER CONSTRUCTI	TOTAL:	74.00
					REPORT GRAND TOTAL:	176,994.71

PKET: 06896 Regular PaymentsSMALLRUN 9-24-

IDOR SET: 01

ID : 01 GENERAL FUND

DEPARTMENT: N/A NON-DEPARTMENTAL

BANK: OPER

GET TO USE: CB-CURRENT BUDGET

IDOR	NAME	ITEM #	G/L ACCOUNT NAME	DESCRIPTION	CHECK#	AMOUNT

001287	AMERICAN EXPRESS					
		I-82810	01 -1402	CLEARING AMEX:JULY 2010 MTGS/TRAV/MBR	118223	6,263.22
002051	VICTOR BALDOVINOS					
		I-91610	01 -1400	PREPAID EXPEN CASH ADVANCE: MILEAGE	118225	151.50
007400	GRANICUS, INC.					
		I-21485	01 -1400	PREPAID EXPEN MANAGED SERV:OCT 2010	118246	538.90
013260	JAMES MITCHIM					
		I-91410	01 -1400	PREPAID EXPEN C/A:TRIP TO SAN MARCOS TEXAS	118261	731.00
020130	TX FLOOD PLAIN MGMT ASS					
		I-91410	01 -1400	PREPAID EXPEN CONFERENCE REGISTRATION	118275	210.00
1	MISC. VENDORS					
MCGRAW, BRANNON CL	I-000201009222756	01 -2424		MUN. COURT BO Bond Refund:713075 -01	118284	50.00
GARCIA, GERARDO AN	I-000201009222757	01 -2424		MUN. COURT BO Bond Refund:851094T -01	118285	33.00
CASTANON, ROBERT	I-000201009222758	01 -2424		MUN. COURT BO Bond Refund:33976A -02	118286	10.00
BUENROSTRO, FABIAN	I-000201009222759	01 -2424		MUN. COURT BO Bond Refund:34097A -01	118287	365.00
ROCHA, ISRAEL JR	I-000201009222760	01 -2424		MUN. COURT BO Bond Refund:34094A -01	118288	67.00
LAPEER, JESSICA CA	I-000201009222761	01 -2424		MUN. COURT BO Bond Refund:34117A -01	118289	67.00
BARRY SCHWARTZ	I-000201009222762	01 -2424		MUN. COURT BO Bond Refund:E0022942 -01	118290	15.00
				DEPARTMENT	NON-DEPARTMENTAL	TOTAL:
						8,501.62

PACKET: 06896 Regular PaymentsSMALLRUN 9-24-

VENDOR SET: 01

FUND : 01 GENERAL FUND

DEPARTMENT: 512 CITY ADMINISTRATION

BANK: OPER

BUDGET TO USE: CB-CURRENT BUDGET

VENDOR	NAME	ITEM #	G/L ACCOUNT NAME	DESCRIPTION	CHECK#	AMOUNT
01-003681	JONI CLARKE	I-92010	01 -512-0550	TRAVEL EXPENS MISC. REIMBURSEMENT	118234	58.68
DEPARTMENT 512 CITY ADMINISTRATION					TOTAL:	58.68

PACKET: 06896 Regular PaymentsSMALLRUN 9-24-

VENDOR SET: 01

FUND : 01 GENERAL FUND

DEPARTMENT: 513 FINANCE DEPARTMENT

BANK: OPER

BUDGET TO USE: CB-CURRENT BUDGET

VENDOR	NAME	ITEM #	G/L ACCOUNT NAME	DESCRIPTION	CHECK#	AMOUNT
01-001129	A & W OFFICE SUPPLY INC	I-436466-0	01 -513-0101	OFFICE SUPPLI 5 BXS.BUSINESS WINDOWENVELOPE	118218	65.95
01-007014	GFOAT	I-82410	01 -513-0551	DUES & MEMBER 2010-2011 MEMBERSHIP FEES	118244	60.00
01-020153	TEXAS STATE BOARD OF PU	I-92010	01 -513-0551	DUES & MEMBER LICENSE & PROFESSIONAL FEE	118276	240.00
DEPARTMENT 513 FINANCE DEPARTMENT					TOTAL:	365.95

PACKET: 06896 Regular PaymentsSMALLRUN 9-24-

VENDOR SET: 01

FUND : 01 GENERAL FUND

DEPARTMENT: 515 TECHNOLOGY DEPARTMENT

BANK: OPER

BUDGET TO USE: CB-CURRENT BUDGET

VENDOR	NAME	ITEM #	G/L ACCOUNT NAME	DESCRIPTION	CHECK#	AMOUNT
01-001142	AT&T GLOBAL SERVICES, I	I-SB618996	01 -515-0415	SERVICE CONTR MAINTENANCE BILLING 9/27-10/26	118219	430.99
01-001161	AT&T	I-7239573488	01 -515-0415	SERVICE CONTR INTERSTATE DEDICATED PRIVATE	118220	437.32
01-004085	DELL	I-XF286DPR8	01 -515-0150	MINOR TOOLS & SLIDING READY RAILS	118236	116.00
01-020906	TYLER TECHNOLOGIES, INC	I-1354	01 -515-0415	SERVICE CONTR ACUCORP./COURT CASE MGMT	118278	1,371.30
DEPARTMENT 515 TECHNOLOGY DEPARTMENT					TOTAL:	2,355.61

PACKET: 06896 Regular PaymentsSMALLRUN 9-24-

VENDOR SET: 01

FUND : 01 GENERAL FUND

DEPARTMENT: 520 MUNICIPAL COURT

BANK: OPER

BUDGET TO USE: CB-CURRENT BUDGET

VENDOR	NAME	ITEM #	G/L ACCOUNT NAME	DESCRIPTION	CHECK#	AMOUNT
01-013410	MUNICIPAL SERVICES BURE	I-45406	01 -520-0531	WARRANT COLLE MUNICIPAL COLLECTIONS	118262	25.00
DEPARTMENT 520 MUNICIPAL COURT					TOTAL:	25.00

PACKET: 06896 Regular PaymentsSMALLRUN 9-24-

VENDOR SET: 01

FUND : 01 GENERAL FUND

DEPARTMENT: 521 POLICE DEPARTMENT

BANK: OPER

BUDGET TO USE: CB-CURRENT BUDGET

VENDOR	NAME	ITEM #	G/L ACCOUNT NAME	DESCRIPTION	CHECK#	AMOUNT
01-003423	CDW GOVERNMENT, INC.					
		I-IVV5542	01 -521-0150	MINOR TOOLS & PD-CID-SONY DIG V/RECORDE	118232	170.27
		I-TWS8449	01 -521-0150	MINOR TOOLS & PD-CID-SONY DIG V/RECORDE	118232	851.35
01-007147	GOVERNMENT CAPITAL CORP					
		I-92110	01 -521-0415	SERVICE CONTR LEASE PAYMENT #5564	118245	22,320.58
01-012023	LEXIS NEXIS					
		I-1008167439	01 -521-0415	SERVICE CONTR PD-1 YR SERV AUG09-SEPT10	118252	152.00
01-012045	MATTHEW BENDER & CO, IN					
		I-06425461	01 -521-0110	K9 SUPPLIES 2-X9 OFFICERS LEGAL HANDBOOK	118253	61.91
01-012103	LONE STAR UNIFORMS, INC.					
		I-184325	01 -521-0130	WEARING APPAR 3 SHIRTS AND CHEVRON/SEALS	118255	151.00
01-020105	TEXAS POLICE CHIEFS ASS					
		I-071410	01 -521-0101	OFFICE SUPPLI POLICE OFFICER ENTRY LEVEL	118274	131.00
DEPARTMENT 521 POLICE DEPARTMENT					TOTAL:	23,838.11

PACKET: 06896 Regular PaymentsSMALLRUN 9-24-

VENDOR SET: 01

FUND : 01 GENERAL FUND

DEPARTMENT: 522 FIRE DEPARTMENT

BANK: OPER

BUDGET TO USE: CB-CURRENT BUDGET

VENDOR	NAME	ITEM #	G/L ACCOUNT NAME	DESCRIPTION	CHECK#	AMOUNT
01-001278	ARMANDO ALVARADO	I-91010	01 -522-0513	TRAINING EXPE MISC.REIMBURSEMENT	118222	64.00
01-002808	BROWN REYNOLDS WATFORD	I-210-08017	01 -522-0530	PROFESSIONAL PROJECT#29132.00	118229	14,528.00
01-003650	MICHAEL CALANDRA	I-91510	01 -522-0130	WEARING APPAR PURCHASE REIMBURSEMENT	118233	99.99
		I-92010	01 -522-0130	WEARING APPAR MISC.REIMIBURSEMENT	118233	19.34
01-008287	HOYT BREATHING AIR PROD	I-23068	01 -522-0530	PROFESSIONAL QUARTERLY SERVICE TESTING	118249	495.00
01-012103	LONE STAR UNIFORMS, INC.	I-187370	01 -522-0130	WEARING APPAR DRESS UNIFORMS FOR LT'S	118255	954.00
		I-187371	01 -522-0130	WEARING APPAR REPLACEMENT DRESS COAT	118255	240.00
01-012120	JEFF LUTRICK	I-91410	01 -522-0117	SAFETY SUPPLI PURCHASE REIMBURSEMENT	118256	150.00
01-012133	LIFE - ASSIST, INC	I-545136	01 -522-0114	MEDICAL MISC. SUPPLIES FOR 1ST RE	118258	2,214.42
01-013136	MANNY'S UNIFORMS	I-11808	01 -522-0130	WEARING APPAR 1-PP01-1810 Z=SIZE 42	118260	44.96
01-019192	SHERWIN WILLIAMS CO.	I-4789-4	01 -522-0150	MINOR TOOLS & AREA RUG FOR DORM	118270	360.00
01-045077	HEATH OLSON	I-90110	01 -522-0130	WEARING APPAR MISC. REIMBURSEMENT	118283	19.49
DEPARTMENT 522 FIRE DEPARTMENT					TOTAL:	19,189.20

PACKET: 06896 Regular PaymentsSMALLRUN 9-24-

VENDOR SET: 01

FUND : 01 GENERAL FUND

DEPARTMENT: 532 CODE ENFORCEMENT

BANK: OPER

BUDGET TO USE: CB-CURRENT BUDGET

VENDOR	NAME	ITEM #	G/L ACCOUNT NAME	DESCRIPTION	CHECK#	AMOUNT	
=====							
01-001949	B & M GENERAL SERVICES						
		I-201009242763	01 -532-0545	LOT MOWING MOWING@1310 PADRE ,LT10,11	118224	24.00	
		I-201009242764	01 -532-0545	LOT MOWING MOWING@102 & 104 E. POMPANO	118224	38.00	
		I-201009242765	01 -532-0545	LOT MOWING MOWING @ 3505 PADRE LT 5BL86	118224	34.00	
		I-201009242766	01 -532-0545	LOT MOWING MOWING @ 102 E.LING, LT30 B40	118224	24.00	
		I-201009242767	01 -532-0545	LOT MOWING MOWING@ 103 E.RED SNAPPER	118224	34.00	
		I-201009242768	01 -532-0545	LOT MOWING MOWING @ 102& 104 W. CAMPECH	118224	59.00	
		I-201009242769	01 -532-0545	LOT MOWING MOWING @ 101 E.CORALEE LT3	118224	48.00	
		I-20100924770	01 -532-0545	LOT MOWING MOWING @ 5700,5704,5708 PADRE	118224	58.00	
01-019644	THE SUPPLIES GUYS						
		I-305502A	01 -532-0101	OFFICE SUPPLI 2-BLK INJET CARTRIDGES	118272	41.88	
					DEPARTMENT 532 CODE ENFORCEMENT	TOTAL:	360.88

PACKET: 06896 Regular PaymentsSMALLRUN 9-24-

VENDOR SET: 01

FUND : 01 GENERAL FUND

DEPARTMENT: 540 FLEET MANAGEMENT

BANK: OPER

BUDGET TO USE: CB-CURRENT BUDGET

VENDOR	NAME	ITEM #	G/L ACCOUNT NAME	DESCRIPTION	CHECK#	AMOUNT
01-002435	BOGGUS MOTOR COMPANY	I-236405	01 -540-0420-01	REPAIRS & MAI F-91 PD. BRAKE PARTS	118227	167.48
01-006241	FUELMAN	I-NP26507290	01 -540-0104-01	FUEL & LUBRIC FUEL PURCHASED IN AUGUST	118242	6,108.73
		I-NP26507290	01 -540-0104-02	FUEL & LUBRIC FUEL PURCHASED IN AUGUST	118242	1,045.20
		I-NP26507290	01 -540-0104-03	FUEL & LUBRIC FUEL PURCHASED IN AUGUST	118242	2,116.65
		I-NP26507290	01 -540-0104-04	FUEL & LUBRIC FUEL PURCHASED IN AUGUST	118242	802.39
01-015012	O'REILLY AUTOMOTIVE, IN	I-400370	01 -540-0420-01	REPAIRS & MAI F-91 PD BRAKES	118264	295.77
01-020200	TIPOTEX CHEVROLET INC.	I-401402	01 -540-0420-01	REPAIRS & MAI 1-TOOL KIT UNIT C-02 PD	118277	83.30
DEPARTMENT 540 FLEET MANAGEMENT					TOTAL:	10,619.52

PACKET: 06896 Regular PaymentsSMALLRUN 9-24-

VENDOR SET: 01

FUND : 01 GENERAL FUND

DEPARTMENT: 541 BUILDING MAINTENANCE

BANK: OPER

BUDGET TO USE: CB-CURRENT BUDGET

VENDOR	NAME	ITEM #	G/L ACCOUNT NAME	DESCRIPTION	CHECK#	AMOUNT
01-020016	TERMINIX	I-298078718	01 -541-0415	SERVICE CONTR PEST CONTROL 4601 PADRE	118273	200.00
DEPARTMENT 541 BUILDING MAINTENANCE					TOTAL:	200.00

PACKET: 06896 Regular PaymentsSMALLRUN 9-24-

VENDOR SET: 01

FUND : 01 GENERAL FUND

DEPARTMENT: 543 PUBLIC WORKS DEPARTMENT

BANK: OPER

BUDGET TO USE: CB-CURRENT BUDGET

VENDOR	NAME	ITEM #	G/L ACCOUNT NAME	DESCRIPTION	CHECK#	AMOUNT
01-007600	GULF COAST PAPER CO. IN					
		C-37663	01 -543-0150	MINOR TOOLS & 15 CS. CAN LINERS RETURNED	118247	288.90-
		I-36965	01 -543-0150	MINOR TOOLS & MISC.TRASH BAGS/CANLINERS	118247	366.50
DEPARTMENT 543 PUBLIC WORKS DEPARTMENT TOTAL:						77.60

PACKET: 06896 Regular PaymentsSMALLRUN 9-24-

VENDOR SET: 01

FUND : 01 GENERAL FUND

DEPARTMENT: 570 GENERAL SERVICES

BANK: OPER

BUDGET TO USE: CB-CURRENT BUDGET

VENDOR	NAME	ITEM #	G/L ACCOUNT NAME	DESCRIPTION	CHECK#	AMOUNT
01-002805	ALLIED WASTE SERVICES #					
		I-0863000401470-1	01 -570-0581	WATER, SEWER, 108 W. RETAMA	118228	1,162.75
01-002909	BUSINESS INK					
		I-35852	01 -570-9174	RECORDS MANAG MINUTE BINDERS	118230	444.02
01-003773	CONSTELLATION NEW ENER					
		I-2467785	01 -570-0580	ELECTRICITY SERV@PADRE BLVD LOT TEMP	118235	31.94
01-004089	DEPT OF INFO RESOURCES					
		I-10080572T	01 -570-0501	COMMUNICATION TEX-AN 2000 CHARGES	118237	181.49
01-004315	ELECTION SYSTEMS & SOFT					
		I-753154	01 -570-9175	ELECTION EXPE 2 EA. SIGN NO TILT/POLL DIST M	118238	80.16
01-006104	FIRST CHOICE POWER COMP					
		I-091710	01 -570-0580	ELECTRICITY SERV @108 W.HUISACHE RRPK	118240	29.90
		I-91910	01 -570-0580	ELECTRICITY SERV @4501 PADRE SEC. ODL	118240	85.32
01-00612	FEDEX					
		I-7-226-76959	01 -570-0108	POSTAGE MISC.SHIPPING CHARGES	118241	62.21
01-009060	INTAB, INC.					
		I-130092A	01 -570-9175	ELECTION EXPE PROVISIONAL BALLOT BOXES	118250	85.55
01-016300	PITNEY BOWES					
		I-6516885-SP10	01 -570-0510	RENTAL OF EQU POSTAGE MIR-JUNE 30 - SEPT30	118269	750.00
01-021095	UNITED PARCEL SERVICE					
		I-000034965X380	01 -570-0108	POSTAGE MISC.SHIPPING CHARGES	118279	80.00
01-023906	XEROX CORPORATION					
		I-050253323	01 -570-0510	RENTAL OF EQU MONTHLY CHG. 8/02-30/10	118282	1,043.63
		I-050253325	01 -570-0510	RENTAL OF EQU COPIER LEASE	118282	1,369.47
DEPARTMENT 570 GENERAL SERVICES					TOTAL:	5,406.44

FUND 01 GENERAL FUND					TOTAL:	70,998.61

PACKET: 06896 Regular PaymentsSMALLRUN 9-24-

VENDOR SET: 01

FUND : 02 HOTEL/MOTEL TAX FUND

DEPARTMENT: N/A NON-DEPARTMENTAL

BANK: OPER

BUDGET TO USE: CB-CURRENT BUDGET

VENDOR	NAME	ITEM #	G/L ACCOUNT NAME	DESCRIPTION	CHECK#	AMOUNT		
01-001287	AMERICAN EXPRESS	I-82810	02 -1402	CLEARING AMEX:JULY 2010 MTGS/TRAV/MBR	118223	9,492.52		
					DEPARTMENT	NON-DEPARTMENTAL	TOTAL:	9,492.52

PACKET: 06896 Regular PaymentsSMALLRUN 9-24-
 VENDOR SET: 01
 FUND : 02 HOTEL/MOTEL TAX FUND
 DEPARTMENT: 590 VISITORS BUREAU
 BUDGET TO USE: CB-CURRENT BUDGET

BANK: OPER

VENDOR	NAME	ITEM #	G/L ACCOUNT NAME	DESCRIPTION	CHECK#	AMOUNT
01-003190	CANTU'S AUTO REPAIR	I-015554	02 -590-0420	MOTOR VEHICLE STATE INSPECTION VISITOR CTR	118231	14.50
01-004089	DEPT OF INFO RESOURCES	I-10080572T	02 -590-0501	COMMUNICATION TEX-AN 2000 CHARGES	118237	44.47
01-006241	FUELMAN	I-NP26507290	02 -590-0104	FUELS & LUBRI FUEL PURCHASED IN AUGUST	118242	49.48
01-016174	PEREZ PEST CONTROL	I-36013	02 -590-0415	SERVICE CONTR PEST CONTROL SERVICE	118268	55.00
01-021095	UNITED PARCEL SERVICE	I-0000648239370	02 -590-0108	POSTAGE MISC. SHIPPING CHARGES	118279	20.00
01-023906	XEROX CORPORATION	I-050048903	02 -590-0415	SERVICE CONTR COPIER RENTAL:8/01-30/10	118282	429.78
DEPARTMENT 590 VISITORS BUREAU					TOTAL:	613.23

PACKET: 06896 Regular PaymentsSMALLRUN 9-24-

VENDOR SET: 01

FUND : 02 HOTEL/MOTEL TAX FUND

DEPARTMENT: 592 SALES & MARKETING

BANK: OPER

BUDGET TO USE: CB-CURRENT BUDGET

VENDOR	NAME	ITEM #	G/L ACCOUNT NAME	DESCRIPTION	CHECK#	AMOUNT
01-004089	DEPT OF INFO RESOURCES					
		I-10080572T	02 -592-0501	COMMUNICATION TEX-AN 2000 CHARGES	118237	8.60
01-00612	FEDEX					
		I-7-226-88083	02 -592-0108	POSTAGE MISC.SHIPPING CHARGES	118241	92.90
01-006241	FUELMAN					
		I-NP26507290	02 -592-0104	FUELS & LUBRI FUEL PURCHASED IN AUGUST	118242	216.06
01-008197	HEADSETS.COM					
		I-2280504-01	02 -592-0101	OFFICE SUPPLI 1-PTR/CS50/BAT FOR HEADSET	118248	47.90
01-012019	CONNIE LEDBETTER					
		I-83110	02 -592-0550	TRAVEL EXPENS MILEAGE REIMBURSEMENT	118251	164.09
		I-90310	02 -592-0550	TRAVEL EXPENS MILEAGE REIMBURSEMENT	118251	569.95
		I-92010	02 -592-0550	TRAVEL EXPENS MISC.REIMBURSEMENT	118251	12.64
01-012059	LOUIE'S BACKYARD					
		I-51810	02 -592-0102	LOCAL MEETING NBA MIXER	118254	108.96
01-016015	PC- NAMETAG					
		C-19014527	02 -592-0538	CONVENTION SE PARTIAL MERCHANDISE RETURNED	118266	128.00-
		I-15330670	02 -592-0538	CONVENTION SE MISC.NAMETAG SUPPLIES	118266	174.36
		I-15331455	02 -592-0538	CONVENTION SE CONVENTION SERVICES	118266	138.95
01-022003	VACATION PLANNING SERVI					
		I-910023	02 -592-0533	MARKETING MONTHLY INQUIRES FOR CVB	118280	294.40
01-022158	VALLEY INTERNATIONAL AI					
		I-SPI NUMBER 05-10	02 -592-0534	AIRPORT SHUTT SPI/VIA AIRPORT SHUTTLE	118281	12,226.98
01-1	MISC. VENDORS					
	CONFERENCE CALL.CO	I-2670320468	02 -592-0501	COMMUNICATION CONFERENCE CALL.COM:	118291	56.18
DEPARTMENT 592 SALES & MARKETING					TOTAL:	13,983.97

PACKET: 06896 Regular PaymentsSMALLRUN 9-24-

VENDOR SET: 01

FUND : 02 HOTEL/MOTEL TAX FUND

DEPARTMENT: 593 EVENTS MARKETING

BANK: OPER

BUDGET TO USE: CB-CURRENT BUDGET

VENDOR	NAME	ITEM #	G/L ACCOUNT NAME	DESCRIPTION	CHECK#	AMOUNT			
01-006241	FUELMAN	I-NP26507290	02 -593-0104	FUEL & LUBRIC FUEL PURCHASED IN AUGUST	118242	97.09			
					DEPARTMENT 593	EVENTS MARKETING	TOTAL:	97.09	
					FUND	02	HOTEL/MOTEL TAX FUND	TOTAL:	24,186.81

PACKET: 06896 Regular PaymentsSMALLRUN 9-24-

VENDOR SET: 01

FUND : 06 CONVENTION CENTER FUND

DEPARTMENT: N/A NON-DEPARTMENTAL

BANK: OPER

BUDGET TO USE: CB-CURRENT BUDGET

VENDOR	NAME	ITEM #	G/L ACCOUNT NAME	DESCRIPTION	CHECK#	AMOUNT		
01-001287	AMERICAN EXPRESS	I-82810	06 -1402	CLEARING AMEX:JULY 2010 MTGS/TRAV/MBR	118223	957.42		
					DEPARTMENT	NON-DEPARTMENTAL	TOTAL:	957.42

PACKET: 06896 Regular PaymentsSMALLRUN 9-24-

VENDOR SET: 01

FUND : 06 CONVENTION CENTER FUND

DEPARTMENT: 565 CONVENTION CENTER OPER

BANK: OPER

BUDGET TO USE: CB-CURRENT BUDGET

VENDOR	NAME	ITEM #	G/L ACCOUNT NAME	DESCRIPTION	CHECK#	AMOUNT			
01-002805	ALLIED WASTE SERVICES #								
		I-0863000384821	06 -565-0581	WATER, SEWER 7355 PADRE BLVD	118228	587.79			
		I-0863000399057	06 -565-0581	WATER, SEWER 7355 PADRE BLVD	118228	587.92			
01-004089	DEPT OF INFO RESOURCES								
		I-10080572T	06 -565-0501	COMMUNICATION TEX-AN 2000 CHARGES	118237	77.26			
01-004405	ESCAPE INTO AQUARIUMS								
		I-90910-2	06 -565-0415	SERVICE CONTR AQUARIUM MAINTENANCE	118239	250.00			
01-006241	FUELMAN								
		I-NP26507290	06 -565-0104	FUELS & LUBRI FUEL PURCHASED IN AUGUST	118242	161.04			
01-007600	GULF COAST PAPER CO. IN								
		I-65579	06 -565-0160	LAUNDRY & JAN JANITORIAL SUPPLIES	118247	383.41			
01-012127	LINK STAFFING SERVICES,								
		I-773767	06 -565-0040	TEMPORARY EMP TEMP.LABOR SEPT.8, 11, 2010	118257	289.20			
01-013111	MARINE ELECTRIC SVC INC								
		I-14598	06 -565-0411	BUILDING & ST EMERGENCY A/C REPAIR	118259	201.50			
01-015027	ORKIN EXTERMINATING CO.								
		I-58348348	06 -565-0415	SERVICE CONTR PEST CONTROL SERVICES	118265	314.96			
		I-58348562	06 -565-0415	SERVICE CONTR PEST CONTROL SERVICES	118265	77.88			
01-019318	SOUTHERN MECHANICAL A/C								
		I-9658421-01	06 -565-1004	MACHINERY & E CHILLER REPLACEMENT	118271	110,000.00			
					DEPARTMENT 565	CONVENTION CENTER OPER	TOTAL:	112,930.96	
					FUND	06	CONVENTION CENTER FUND	TOTAL:	113,888.38

PACKET: 06896 Regular PaymentsSMALLRUN 9-24-

VENDOR SET: 01

FUND : 21 MUN. COURT TECHNOLOGY

DEPARTMENT: 520 MUN COURT TECHNOLOGY

BANK: OPER

BUDGET TO USE: CB-CURRENT BUDGET

VENDOR	NAME	ITEM #	G/L ACCOUNT NAME	DESCRIPTION	CHECK#	AMOUNT
01-016056	PRINTER EXPERTS, LLC					
		I-100001432	21 -520-0150	MINOR TOOLS & PRINTER TONER	118267	140.00
DEPARTMENT 520 MUN COURT TECHNOLOGY					TOTAL:	140.00
FUND 21 MUN. COURT TECHNOLOGY					TOTAL:	140.00

PACKET: 06896 Regular PaymentsSMALLRUN 9-24-

VENDOR SET: 01

FUND : 30 TRANSPORTAION GRANT

DEPARTMENT: 591 TRANSPORTATION DEPT

BANK: OPER

BUDGET TO USE: CB-CURRENT BUDGET

VENDOR	NAME	ITEM #	G/L ACCOUNT NAME	DESCRIPTION	CHECK#	AMOUNT
=====						
01-002196	BLANCO'S DETAILING SERV					
		I-177	30 -591-0420	MOTOR VEHICLE WASH & DETAIL BUSES-	118226	400.00
		I-179	30 -591-0420	MOTOR VEHICLE WASH & DETAIL BUSES-	118226	200.00
01-002435	BOGGUS MOTOR COMPANY					
		I-C47240	30 -591-0420	MOTOR VEHICLE BUS FUEL PARTS	118227	475.02
01-006241	FUELMAN					
		I-NP26507290	30 -591-0104	FUELS & LUBRI FUEL PURCHASED IN AUGUST	118242	8,468.97
01-006997	G & K SERVICES					
		I-1103470674	30 -591-0130	WEARING APPAR UNIFORMS	118243	102.76
		I-1103473901	30 -591-0130	WEARING APPAR UNIFORMS	118243	104.07
		I-1103477155	30 -591-0130	WEARING APPAR UNIFORMS	118243	102.76
		I-1103480405	30 -591-0130	WEARING APPAR UNIFORMS	118243	102.76
01-014033	NTC DRUG TESTING SERVIC					
		I-27751	30 -591-0530	PROFESSIONAL RANDOM DRUG /ALCOHOL SCREEN	118263	80.00
		I-27903	30 -591-0530	PROFESSIONAL DOT RANDOM DRUG SCREEN	118263	34.00
01-020016	TERMINIX					
		I-298055089	30 -591-0411	BUILDING & ST PEST CONTROL BUS BARN	118273	41.00
					DEPARTMENT 591	10,111.34
					TRANSPORTATION DEPT	
					TOTAL:	10,111.34

					FUND	10,111.34
					30	
					TRANSPORTAION GRANT	
					TOTAL:	10,111.34

PACKET: 06896 Regular PaymentsSMALLRUN 9-24-

VENDOR SET: 01

FUND : 60 BEACH MAINTENANCE FUND

DEPARTMENT: 560 BEACH MAINTENANCE

BANK: OPER

BUDGET TO USE: CB-CURRENT BUDGET

VENDOR	NAME	ITEM #	G/L ACCOUNT NAME	DESCRIPTION	CHECK#	AMOUNT
01-006241	FUELMAN	I-NP26507290	60 -560-0104	FUEL & LUBRIC FUEL PURCHASED IN AUGUST	118242	1,354.85
01-007600	GULF COAST PAPER CO. IN	I-66542	60 -560-0510	EXCESS BEACH DRUM LINERS	118247	492.91
					DEPARTMENT 560 BEACH MAINTENANCE	TOTAL: 1,847.76
					FUND 60 BEACH MAINTENANCE FUND	TOTAL: 1,847.76

PACKET: 06896 Regular PaymentsSMALLRUN 9-24-

VENDOR SET: 01

FUND : 80 ECONOMIC DEVELOPMENT CORP

DEPARTMENT: 581 BIRDING CENTER

BANK: OPER

BUDGET TO USE: CB-CURRENT BUDGET

VENDOR	NAME	ITEM #	G/L ACCOUNT NAME	DESCRIPTION	CHECK#	AMOUNT
01-001161	AT&T	I-90510	80 -581-0501	COMMUNICATION EDC/SPIBNC:INTERNET SRV	118221	382.50
				DEPARTMENT 581 BIRDING CENTER	TOTAL:	382.50
			FUND 80	ECONOMIC DEVELOPMENT CORP	TOTAL:	382.50
					REPORT GRAND TOTAL:	221,555.40

PKET: 06930 AP CHECK RUN 10-01-10

ADOR SET: 01

ID : 01 GENERAL FUND

DEPARTMENT: N/A NON-DEPARTMENTAL

BANK: OPER

BUDGET TO USE: CB-CURRENT BUDGET

ADOR	NAME	ITEM #	G/L ACCOUNT NAME	DESCRIPTION	CHECK#	AMOUNT
=====						
001297	AMERICAN FUNDS					
		I-201009302795	01 -2485	AMERICAN GENE AMERICAN FUNDS	118299	83.08
002101	BEST LITTLE WAREHOUSE I					
		I-92210	01 -1400	PREPAID EXPEN XMAS STORAGE RENTAL OCT -NOV	118305	170.00
002200	BLUE CROSS BLUE SHIELD					
		I-201009302799	01 -2462	BLUE CROSS DE BLUE CROSS BLUE SHIELD	118308	1,584.06
002434	CINDY BOUDLOCHE, TRUSTE					
		I-DW5201009272771	01 -2469	DEBTORS WAGE A/N 07-10758-B-13	118310	662.30
		I-DW9201009272771	01 -2469	DEBTORS WAGE CASE NO 10-10137-B-13	118311	490.38
003185	OFFICE OF THE ATTY GENL					
		I-C09201009272771	01 -2473	CHILD SUPPORT A/N 0010486563	118316	212.31
		I-C10201009272771	01 -2473	CHILD SUPPORT A/N 2004094864B	118317	282.92
		I-C14201009272771	01 -2473	CHILD SUPPORT A/N N002589726	118318	100.00
		I-C24201009272771	01 -2473	CHILD SUPPORT A/N 0011488748	118319	462.18
		I-C31201009272771	01 -2473	CHILD SUPPORT A/N 0011545222	118320	161.54
		I-C32201009272771	01 -2473	CHILD SUPPORT A/N 2007031654D	118321	338.35
		I-C34201009272771	01 -2473	CHILD SUPPORT A/N 0009255855	118322	43.44
		I-C37201009272771	01 -2473	CHILD SUPPORT A/N 2008-10-5941-D	118323	492.46
		I-C47201009272771	01 -2473	CHILD SUPPORT CASE # 0009943810	118324	141.68
		I-C48201009272771	01 -2473	CHILD SUPPORT NO. 2008-08-4758-E	118325	383.08
		I-C49201009272771	01 -2473	CHILD SUPPORT 0009648707	118326	165.69
		I-C50201009272771	01 -2473	CHILD SUPPORT AG CASE #0011346896	118327	634.62
006163	AMERICAN GENERAL LIFE I					
		I-201009302796	01 -2485	AMERICAN GENE AMERICAN GENERAL LIFE INS	118350	528.78
007001	ANA GARZA					
		I-C04201009272771	01 -2473	CHILD SUPPORT A/N 2003-03-1480-B	118352	194.88
009097	INTERNAL REVENUE SERVIC					
		I-IR6201009272771	01 -2459	IRS LEVY A/N XXX-XX-1603	118360	383.00
012108	HERMELINDA LONGORIA					
		I-C16201009272771	01 -2473	CHILD SUPPORT A/N 2002031289D	118371	146.77
016686	PUTNAM INVESTMENTS					
		I-201009302794	01 -2485	AMERICAN GENE PUTNAM INVESTMENTS	118392	62.15
019997	TG					
		I-DX1201009272771	01 -2469	DEBTORS WAGE CS239406800	118411	160.51
020615	TOWN OF SOUTH PADRE ISL					
		I-201009302793	01 -2479	EMPLOYEE ACTI TOWN OF SOUTH PADRE ISLAND	118424	130.00
020700	TRANSAMERICA WORKSITE M					

PACKET: 06930 AP CHECK RUN 10-01-10

VENDOR SET: 01

FUND : 01 GENERAL FUND

DEPARTMENT: N/A NON-DEPARTMENTAL

BANK: OPER

BUDGET TO USE: CB-CURRENT BUDGET

VENDOR	NAME	ITEM #	G/L ACCOUNT NAME	DESCRIPTION	CHECK#	AMOUNT

01-020700	TRANSAMERICA WORKSITE M	continued				
		I-201009302798	01 -2464	TRANSAMERICA TRANSAMERICA WORKSITE MKT	118426	15.17
01-023200	MICHELLE WILBURN					
		I-C21201009272771	01 -2473	CHILD SUPPORT A/N 0011549506	118439	146.31
01-1	MISC. VENDORS					
	NIEMIETZ, ANGELA A	I-000201009272772	01 -2424	MUN. COURT BO Bond Refund:33419A -01	118443	15.00
	STANTON, ALAN LYNN	I-000201009272773	01 -2424	MUN. COURT BO Bond Refund:33492A -02	118444	67.00
	TAYLOR, DALTON	I-000201009272774	01 -2424	MUN. COURT BO Bond Refund:33565A -01	118445	67.00
	GONZALEZ, GUILLERM	I-000201009272775	01 -2424	MUN. COURT BO Bond Refund:33863A -01	118446	202.00
	MEANS, VANESSA	I-000201009272776	01 -2424	MUN. COURT BO Bond Refund:E0013907 -01	118447	52.00
	HERNANDEZ, RIGOBER	I-000201009282777	01 -2424	MUN. COURT BO Bond Refund:E0018048 -02	118448	171.00
	DEAUMAN, MARIA BRI	I-000201009282778	01 -2424	MUN. COURT BO Bond Refund:34002A -01	118449	199.00
	BRIDWELL, HUNTER R	I-000201009302802	01 -2424	MUN. COURT BO Bond Refund:839059T -02	118450	33.00
	GONZALEZ, DANIEL	I-000201009302803	01 -2424	MUN. COURT BO Bond Refund:851095T -02	118451	33.00
	MACKLIN, KEVIN	I-000201009302804	01 -2424	MUN. COURT BO Bond Refund:833675T -02	118452	33.00
	PAULA WESTMORELAND	I-92010	01 -47036	HEALTH PERMIT PAULA WESTMORELAND:REFUND	118467	25.00
				DEPARTMENT	NON-DEPARTMENTAL	TOTAL:
						9,072.66

PACKET: 06930 AP CHECK RUN 10-01-10

VENDOR SET: 01

FUND : 01 GENERAL FUND

DEPARTMENT: 512 CITY ADMINISTRATION

BANK: OPER

BUDGET TO USE: CB-CURRENT BUDGET

VENDOR	NAME	ITEM #	G/L ACCOUNT NAME	DESCRIPTION	CHECK#	AMOUNT
01-001129	A & W OFFICE SUPPLY INC	I-438587-0	01 -512-0101	OFFICE SUPPLI INDEX TABS,FLDR,LABELS	118295	160.03
01-002200	BLUE CROSS BLUE SHIELD	I-201009302799	01 -512-0081	GROUP INSURAN BLUE CROSS BLUE SHIELD	118308	132.75
01-003250	CASH	I-93010	01 -512-0102	LOCAL MEETING REIMBURSE CITY HALL PETTY CASH	118329	25.98
01-006133	FORT DEARBORN LIFE INS	I-201009302805	01 -512-0081	GROUP INSURAN FORT DEARBORN LIFE INS CO	118347	21.11
01-013166	MINERVA E. LOPEZ	I-91810	01 -512-0550	TRAVEL EXPENS MILEAGE REIMBURSEMENT	118373	149.72
01-016098	PADRE ISLAND HEALTH SPE	I-201009302800	01 -512-0530	PROFESSIONAL 5 PANEL DRUG TEST :FEB. MARCH	118382	25.00
01-018509	SAM'S CLUB DIRECT	I-000761	01 -512-0101	OFFICE SUPPLI OFFICE SUPPLIES	118398	8.47
01-023053	WALMART COMMUNITY	I-007140	01 -512-0101	OFFICE SUPPLI REPLACEMENT KEYBOARD, MINTS	118432	50.20
DEPARTMENT 512 CITY ADMINISTRATION					TOTAL:	573.26

PACKET: 06930 AP CHECK RUN 10-01-10

VENDOR SET: 01

FUND : 01 GENERAL FUND

DEPARTMENT: 513 FINANCE DEPARTMENT

BANK: OPER

BUDGET TO USE: CB-CURRENT BUDGET

VENDOR	NAME	ITEM #	G/L ACCOUNT NAME	DESCRIPTION	CHECK#	AMOUNT
01-002200	BLUE CROSS BLUE SHIELD					
		I-201009302799	01 -513-0081	GROUP INSURAN BLUE CROSS BLUE SHIELD	118308	132.75
01-006133	FORT DEARBORN LIFE INS					
		I-201009302805	01 -513-0081	GROUP INSURAN FORT DEARBORN LIFE INS CO	118347	163.78
01-019101	SEARS COMMERCIAL ONE					
		C-T000008	01 -513-0130	WEARING APPAR 1- SWEATER RETURNED	118401	7.99-
		I-T466176	01 -513-0130	WEARING APPAR 13-BLOUSES/SWEATERS -STAFF	118401	149.81
01-019991	TEAM GRAPHIX & AWARDS					
		I-20100466	01 -513-0130	WEARING APPAR LOGO EMBROIDERED ON 14 ITEMS	118410	98.00
DEPARTMENT 513 FINANCE DEPARTMENT					TOTAL:	536.35

PACKET: 06930 AP CHECK RUN 10-01-10

VENDOR SET: 01

FUND : 01 GENERAL FUND

DEPARTMENT: 514 PLANNING DEPARTMENT

BANK: OPER

BUDGET TO USE: CB-CURRENT BUDGET

VENDOR	NAME	ITEM #	G/L ACCOUNT NAME	DESCRIPTION	CHECK#	AMOUNT
01-001200	L.R.G.V.D.C.					
		I-001	01 -514-0513	TRAINING EXPE GIS/GPS TRAINING	118296	200.00
01-002200	BLUE CROSS BLUE SHIELD					
		I-201009302799	01 -514-0081	GROUP INSURAN BLUE CROSS BLUE SHIELD	118308	53.10
01-003250	CASH					
		I-93010	01 -514-0102	LOCAL MEETING REIMBURSE CITY HALL PETTY CASH	118329	8.73
01-006133	FORT DEARBORN LIFE INS					
		I-201009302805	01 -514-0081	GROUP INSURAN FORT DEARBORN LIFE INS CO	118347	75.04
DEPARTMENT 514 PLANNING DEPARTMENT					TOTAL:	336.87

PACKET: 06930 AP CHECK RUN 10-01-10

VENDOR SET: 01

FUND : 01 GENERAL FUND

DEPARTMENT: 515 TECHNOLOGY DEPARTMENT

BANK: OPER

BUDGET TO USE: CB-CURRENT BUDGET

VENDOR	NAME	ITEM #	G/L ACCOUNT NAME	DESCRIPTION	CHECK#	AMOUNT
01-002200	BLUE CROSS BLUE SHIELD	I-201009302799	01 -515-0081	GROUP INSURAN BLUE CROSS BLUE SHIELD	118308	79.65
01-006133	FORT DEARBORN LIFE INS	I-201009302805	01 -515-0081	GROUP INSURAN FORT DEARBORN LIFE INS CO	118347	99.24
01-020602	TOUCAN GRAPHICS	I-10827	01 -515-0130	WEARING APPAR 2-NAME BADGES:C.CENTENO	118423	36.68
01-043000	ESRI INC.	I-92225604	01 -515-0415	SERVICE CONTR ARCVIEW CONCURRENT USE	118442	1,537.53
DEPARTMENT 515 TECHNOLOGY DEPARTMENT					TOTAL:	1,753.10

PACKET: 06930 AP CHECK RUN 10-01-10

VENDOR SET: 01

FUND : 01 GENERAL FUND

DEPARTMENT: 516 HUMAN RESOURCES

BANK: OPER

BUDGET TO USE: CB-CURRENT BUDGET

VENDOR	NAME	ITEM #	G/L ACCOUNT NAME	DESCRIPTION	CHECK#	AMOUNT
01-002200	BLUE CROSS BLUE SHIELD					
		I-201009302799	01 -516-0081	GROUP INSURAN BLUE CROSS BLUE SHIELD	118308	26.55
01-006133	FORT DEARBORN LIFE INS					
		I-201009302805	01 -516-0081	GROUP INSURAN FORT DEARBORN LIFE INS CO	118347	13.35
DEPARTMENT 516 HUMAN RESOURCES					TOTAL:	39.90

PACKET: 06930 AP CHECK RUN 10-01-10

VENDOR SET: 01

FUND : 01 GENERAL FUND

DEPARTMENT: 520 MUNICIPAL COURT

BANK: OPER

BUDGET TO USE: CB-CURRENT BUDGET

VENDOR	NAME	ITEM #	G/L ACCOUNT NAME	DESCRIPTION	CHECK#	AMOUNT
01-002200	BLUE CROSS BLUE SHIELD	I-201009302799	01 -520-0081	GROUP INSURAN BLUE CROSS BLUE SHIELD	118308	53.10
01-003812	BUSINESS MANAGEMENT DAI	I-92810	01 -520-0107	BOOKS & PERIO PERIODICAL SUBSCRIPTION	118337	79.00
01-004025	ERLE DANIELS	I-201009292781	01 -520-0530	PROFESSIONAL JURY DUTY COMPENSATION	118339	6.00
01-006133	FORT DEARBORN LIFE INS	I-201009302805	01 -520-0081	GROUP INSURAN FORT DEARBORN LIFE INS CO	118347	53.20
01-020209	TEXAS CORRECTIONS INDUS	I-240890 RI	01 -520-0401	FURNITURE & F TEXAS	118420	189.10
01-023174	STEPHANIE WILSON	I-92310	01 -520-0530	PROFESSIONAL COMPENSATION FOR JURY DUTY	118438	12.00
01-1	MISC. VENDORS					
	ELISE SANCHEZ	I-201009292779	01 -520-0530	PROFESSIONAL ELISE SANCHEZ:JURY DUTY	118454	12.00
	DEANNA BOWMAN	I-201009292780	01 -520-0530	PROFESSIONAL DEANNA BOWMAN:JURY DUTY	118455	12.00
	ELIZABETH DANIELS	I-201009292782	01 -520-0530	PROFESSIONAL ELIZABETH DANIELS:JURY DUTY	118456	6.00
	DANIEL MEEKS	I-201009292783	01 -520-0530	PROFESSIONAL DANIEL MEEKS:JURY DUTY	118457	6.00
	HELEN WILLIAMS	I-201009292784	01 -520-0530	PROFESSIONAL HELEN WILLIAMS:JURY DUTY	118458	6.00
	MARGARET LEEMAN	I-201009292785	01 -520-0530	PROFESSIONAL MARGARET LEEMAN:JURY DUTY	118459	6.00
	THOMAS LEEMAN	I-201009292786	01 -520-0530	PROFESSIONAL THOMAS LEEMAN:JURY DUTY	118460	6.00
	WALTER R. CONRAD	I-201009292787	01 -520-0530	PROFESSIONAL WALTER R. CONRAD:JURY DUTY	118461	6.00
	SANDY COLWELL	I-201009292788	01 -520-0530	PROFESSIONAL SANDY COLWELL:JURY DUTY	118462	6.00
	MARY CHASE	I-201009292789	01 -520-0530	PROFESSIONAL MARY CHASE:JURY DUTY	118463	6.00
	ROSAENA DELEON	I-201009292790	01 -520-0530	PROFESSIONAL ROSAENA DELEON:JURY DUTY	118464	6.00
	JAMES E.CARLSON	I-201009292791	01 -520-0530	PROFESSIONAL JAMES E.CARLSON: JURY DUTY	118465	6.00
	LYNDA M.BREEZE	I-201009292792	01 -520-0530	PROFESSIONAL LYNDA M.BREEZE:JURY DUTY	118466	6.00

DEPARTMENT 520 MUNICIPAL COURT TOTAL: 482.40

PACKET: 06930 AP CHECK RUN 10-01-10

VENDOR SET: 01

FUND : 01 GENERAL FUND

DEPARTMENT: 521 POLICE DEPARTMENT

BANK: OPER

BUDGET TO USE: CB-CURRENT BUDGET

VENDOR	NAME	ITEM #	G/L ACCOUNT NAME	DESCRIPTION	CHECK#	AMOUNT
01-002200	BLUE CROSS BLUE SHIELD	I-201009302799	01 -521-0081	GROUP INSURAN BLUE CROSS BLUE SHIELD	118308	959.41
01-003250	CASH	I-93010	01 -521-0150	MINOR TOOLS & REIMBURSE CITY HALL PETTY CASH	118329	12.96
01-003423	CDW GOVERNMENT, INC.	I-TW25811	01 -521-0150	MINOR TOOLS & PD-CID-SONY DIG V/RECORDE	118332	170.27
01-006101	FIRST CHECK APPLICANT S	I-11454	01 -521-0530	PROFESSIONAL PRE-EMPLOYMENT SCREENING	118345	148.75
01-006116	JOE KING JR.	I-24691	01 -521-0150	MINOR TOOLS & MISC. STICKERS FOR PD	118346	59.52
01-006133	FORT DEARBORN LIFE INS	I-201009302805	01 -521-0081	GROUP INSURAN FORT DEARBORN LIFE INS CO	118347	1,111.31
01-007006	GT DISTRIBUTORS, INC.	I-INV0325790	01 -521-0130	WEARING APPAR 15- NAMEPLATES	118353	134.25
01-012103	LONE STAR UNIFORMS, INC.	I-187444	01 -521-0130	WEARING APPAR 2-REG DARK NAVY KNIT	118370	112.00
01-016098	PADRE ISLAND HEALTH SPE	I-201009302800	01 -521-0530	PROFESSIONAL 5 PANEL DRUG TEST :FEB. MARCH	118382	275.00
		I-201009302801	01 -521-0530	PROFESSIONAL 5-PANEL DRUG TEST :FEB MARCH	118382	450.00
01-018046	ISLA GRAND BEACH RESORT	I-92410	01 -521-0102	LOCAL MEETING EMPLOYEE APPRECIATION BRKFST	118393	1,029.50
01-019239	SOUTH PADRE OFFICE CENT	I-100639	01 -521-0101	OFFICE SUPPLI 1-HP 96 BLK INK CARTRIDGE	118404	39.99
01-023053	WALMART COMMUNITY	I-004979	01 -521-0110	K9 SUPPLIES MISC.K-9 SUPPLIES/FOOD	118432	118.00
		I-004979	01 -521-0150	MINOR TOOLS & MISC.K-9 SUPPLIES/FOOD	118432	29.00
		I-04978	01 -521-0150	MINOR TOOLS & TIRE SHINE,ARMOR ALL,ETC	118432	136.82
01-023058	WHATABURGER	I-693400	01 -521-0571	FOOD FOR PRIS PRISONER MEALS	118434	3.84
01-024201	ZEE MEDICAL SERVICE	I-0039611002	01 -521-0150	MINOR TOOLS & MISC. FIRST AID SUPPLIES	118440	97.40
01-1	MISC. VENDORS					
	MOIRA H. FOLEY, RN	I-10-0771568	01 -521-0530	PROFESSIONAL MOIRA H. FOLEY, RN, SANE-A:	118453	521.00
DEPARTMENT 521 POLICE DEPARTMENT					TOTAL:	5,409.02

PACKET: 06930 AP CHECK RUN 10-01-10

VENDOR SET: 01

FUND : 01 GENERAL FUND

DEPARTMENT: 522 FIRE DEPARTMENT

BANK: OPER

BUDGET TO USE: CB-CURRENT BUDGET

VENDOR	NAME	ITEM #	G/L ACCOUNT NAME	DESCRIPTION	CHECK#	AMOUNT
01-002200	BLUE CROSS BLUE SHIELD	I-201009302799	01 -522-0081	GROUP INSURAN BLUE CROSS BLUE SHIELD	118308	557.55
01-003250	CASH	I-93010	01 -522-0113	BATTERIES REIMBURSE CITY HALL PETTY CASH	118329	12.23
01-003680	TEXAS COMM ON FIRE PROT	I-92010	01 -522-0513	TRAINING EXPE CERTIFICATION FEES	118334	170.00
01-006086	WITMER ASSOCIATES, INC.	I-1047972	01 -522-0117	SAFETY SUPPLI 1PR WATERPROOF BOOTS:BARKER	118344	121.94
		I-1056307	01 -522-0117	SAFETY SUPPLI REPLACEMENT/NEW HELMET	118344	476.99
		I-889284	01 -522-0117	SAFETY SUPPLI NEW DUTY BOOTS:J. CISKI	118344	233.99
01-006101	FIRST CHECK APPLICANT S	I-11454	01 -522-0530	PROFESSIONAL PRE-EMPLOYMENT SCREENING	118345	42.50
01-006133	FORT DEARBORN LIFE INS	I-201009302805	01 -522-0081	GROUP INSURAN FORT DEARBORN LIFE INS CO	118347	517.27
01-007075	GALLS	I-510788516	01 -522-0117	SAFETY SUPPLI 2-INST.EMER.RAPELLING BELTS	118354	80.97
		I-510812298	01 -522-0117	SAFETY SUPPLI 1-INST. EMR.RAPELLING BELT	118354	43.98
01-013423	MUNICIPAL FIRE APPARATU	I-81B	01 -522-0410	MACHINERY & E EERGENCY REPAIRS - JAWS	118375	460.00
01-015012	O'REILLY AUTOMOTIVE, IN	I-400483	01 -522-0150	MINOR TOOLS & BRAKE CLNR,LUBRICANT	118380	27.14
		I-402467	01 -522-0150	MINOR TOOLS & 3- 12 OZ LUBRICANT	118380	17.97
		I-402825	01 -522-0150	MINOR TOOLS & 2-WIPER BLADES	118380	23.98
		I-402826	01 -522-0150	MINOR TOOLS & 2-WIPER BLADES	118380	38.97
01-016098	PADRE ISLAND HEALTH SPE	I-201009302800	01 -522-0530	PROFESSIONAL 5 PANEL DRUG TEST :FEB. MARCH	118382	25.00
		I-201009302801	01 -522-0530	PROFESSIONAL 5-PANEL DRUG TEST :FEB MARCH	118382	75.00
		I-82610	01 -522-0530	PROFESSIONAL PPHYSICAL & DRUG SCREEN	118382	50.00
01-016110	PADRE ISLAND'S ACE HARD	I-066052	01 -522-0150	MINOR TOOLS & 2-5 GAL.PVC PAILS	118383	9.98
		I-066219	01 -522-0150	MINOR TOOLS & PAINT BRUSHES, MASKING TAPE	118383	9.76
		I-066258	01 -522-0150	MINOR TOOLS & 1 QT METALTREATMENT/BRUSH	118383	13.57
		I-066277	01 -522-0150	MINOR TOOLS & 10 PC WRENCH SET, MISC. HDW	118383	53.69
		I-066641	01 -522-0150	MINOR TOOLS & MISC.HARDWARE	118383	4.16
		I-066768	01 -522-0150	MINOR TOOLS & SPARK PLUG, INSECT REPELLANT	118383	12.77
		I-066856	01 -522-0150	MINOR TOOLS & DRILLBIT,MISC. HDW	118383	5.23
01-016247	JIM PIGG	I-201009302797	01 -522-0117	SAFETY SUPPLI JIM PIGG	118388	49.99

PACKET: 06930 AP CHECK RUN 10-01-10

VENDOR SET: 01

FUND : 01 GENERAL FUND

DEPARTMENT: 522 FIRE DEPARTMENT

BANK: OPER

BUDGET TO USE: CB-CURRENT BUDGET

VENDOR	NAME	ITEM #	G/L ACCOUNT NAME	DESCRIPTION	CHECK#	AMOUNT		
=====								
01-018509	SAM'S CLUB DIRECT							
		I-000761	01 -522-0160	LAUNDRY & JAN MISC. SUPPLIES	118398	222.76		
		I-000761	01 -522-0170	DORM AND KITC MISC. SUPPLIES	118398	94.42		
01-023053	WALMART COMMUNITY							
		I-003313	01 -522-0101	OFFICE SUPPLI REPLACEMENT VACUME	118432	52.67		
		I-003313	01 -522-0113	BATTERIES REPLACEMENT VACUME	118432	126.67		
		I-003313	01 -522-0150	MINOR TOOLS & REPLACEMENT VACUME	118432	72.50		
		I-003313	01 -522-0160	LAUNDRY & JAN REPLACEMENT VACUME	118432	26.36		
		I-003313	01 -522-0170	DORM AND KITC REPLACEMENT VACUME	118432	39.92		
		I-003313	01 -522-0410	MACHINERY & E REPLACEMENT VACUME	118432	153.88		
		I-007568	01 -522-0101	OFFICE SUPPLI 1ST AIDSUPPLIES, CLIPS, ETC	118432	9.00		
		I-007568	01 -522-0114	MEDICAL 1ST AIDSUPPLIES, CLIPS, ETC	118432	19.48		
		I-007568	01 -522-0170	DORM AND KITC 1ST AIDSUPPLIES, CLIPS, ETC	118432	9.20		
		I-01055	01 -522-0150	MINOR TOOLS & TIRE SCRAPER, KNIFES, ETC	118432	81.98		
		I-09958	01 -522-0113	BATTERIES MISC. SUPPLIES FOR FIRE	118432	66.32		
		I-09958	01 -522-0160	LAUNDRY & JAN MISC. SUPPLIES FOR FIRE	118432	32.43		
		I-09958	01 -522-0170	DORM AND KITC MISC. SUPPLIES FOR FIRE	118432	94.64		
					DEPARTMENT 522	FIRE DEPARTMENT	TOTAL:	4,236.86

PACKET: 06930 AP CHECK RUN 10-01-10

VENDOR SET: 01

FUND : 01 GENERAL FUND

DEPARTMENT: 532 CODE ENFORCEMENT

BANK: OPER

BUDGET TO USE: CB-CURRENT BUDGET

VENDOR	NAME	ITEM #	G/L ACCOUNT NAME	DESCRIPTION	CHECK#	AMOUNT
01-001129	A & W OFFICE SUPPLY INC	I-438419-0	01 -532-0101	OFFICE SUPPLI LTR FOLDERS, STAPLER,WITEOUT	118295	81.81
01-001200	L.R.G.V.D.C.	I-001	01 -532-0513	TRAINING EXPE GIS/GPS TRAINING	118296	200.00
01-001322	AMERICAN ASSOC. OF NOTA	I-90910	01 -532-0101	OFFICE SUPPLI NOTARY SUPPLIES : AMY BUSH	118300	50.80
01-001360	CODE ENFORCEMENT ASSC.	I-91010	01 -532-0551	DUES & MEMBER MEMBERSHIP RENEWAL	118302	320.00
01-002200	BLUE CROSS BLUE SHIELD	I-201009302799	01 -532-0081	GROUP INSURAN BLUE CROSS BLUE SHIELD	118308	159.30
01-003250	CASH	I-93010	01 -532-0101	OFFICE SUPPLI REIMBURSE CITY HALL PETTY CASH	118329	8.49
		I-93010	01 -532-0551	DUES & MEMBER REIMBURSE CITY HALL PETTY CASH	118329	12.00
01-006133	FORT DEARBORN LIFE INS	I-201009302805	01 -532-0081	GROUP INSURAN FORT DEARBORN LIFE INS CO	118347	139.28
01-016098	PADRE ISLAND HEALTH SPE	I-201009302800	01 -532-0530	PROFESSIONAL 5 PANEL DRUG TEST :FEB. MARCH	118382	100.00
		I-201009302801	01 -532-0530	PROFESSIONAL 5-PANEL DRUG TEST :FEB MARCH	118382	175.00
01-016110	PADRE ISLAND'S ACE HARD	I-066402	01 -532-0150	MINOR TOOLS & CABLE TIES	118383	9.99
		I-066689	01 -532-0150	MINOR TOOLS & RAZOR BLADES & HOLDER	118383	6.97
01-016608	PORT ISABEL ANIMAL CLIN	I-29932	01 -532-0530	PROFESSIONAL RABIES SPECIMEN PREP:	118390	65.00
01-020008	TEXAS ANIMAL CONTROL AS	I-91010	01 -532-0551	DUES & MEMBER MEMBERSHIP RENEWAL	118412	400.00
01-020174	TEXAS DEPT. OF STATE HE	I-91410	01 -532-0551	DUES & MEMBER CERTIFICATE RENEWAL	118417	10.00
DEPARTMENT 532 CODE ENFORCEMENT					TOTAL:	1,738.64

PACKET: 06930 AP CHECK RUN 10-01-10

VENDOR SET: 01

FUND : 01 GENERAL FUND

DEPARTMENT: 540 FLEET MANAGEMENT

BANK: OPER

BUDGET TO USE: CB-CURRENT BUDGET

VENDOR	NAME	ITEM #	G/L ACCOUNT NAME	DESCRIPTION	CHECK#	AMOUNT
01-002200	BLUE CROSS BLUE SHIELD	I-201009302799	01 -540-0081	GROUP INSURAN BLUE CROSS BLUE SHIELD	118308	53.10
01-006083	FAST & FAIR CAR CARE	I-1355	01 -540-0420-01	REPAIRS & MAI 8 TIRES RECYCLED	118343	40.00
01-006133	FORT DEARBORN LIFE INS	I-201009302805	01 -540-0081	GROUP INSURAN FORT DEARBORN LIFE INS CO	118347	56.24
01-006998	GCR TIRE CENTER#1133	I-66651	01 -540-0111	TIRES & TUBES 4- TIRES FOR TAHOES	118351	816.00
		I-66652	01 -540-0111	TIRES & TUBES 4- TIRES FOR UNIT C-02-C-03	118351	816.00
		I-66653	01 -540-0111	TIRES & TUBES #36 PWD TIRES	118351	444.40
		I-67478	01 -540-0420-03	REPAIRS & MAI 43 PWD TIRES	118351	210.00
01-009657	JAIME'S TIRE STORE	I-049542	01 -540-0420-03	REPAIRS & MAI 1-ALIGNMENT TOESET	118365	39.00
01-011993	LA FERIA WRECKER SERVIC	I-36640	01 -540-0420-02	REPAIRS & MAI EMERGENCY WRECKER SERVICE	118367	475.00
01-014030	NAPA AUTO PARTS	I-574121	01 -540-0420-03	REPAIRS & MAI 2-FUEL /1 OIL FILTER UNIT #30	118377	31.77
		I-574323	01 -540-0420-03	REPAIRS & MAI 1-BEARING PULLER -SCAGG MOWER	118377	26.99
		I-574539	01 -540-0420-02	REPAIRS & MAI 7-QTS. OIL, 4-SMALL ENG. PLUGS	118377	31.65
		I-574540	01 -540-0420-03	REPAIRS & MAI 3-AIR FILTERS LAWN MOWERS	118377	17.10
		I-574541	01 -540-0420-03	REPAIRS & MAI 4-SPARK PLUGS - LAWN MOWERS	118377	7.16
		I-574559	01 -540-0420-04	REPAIRS & MAI 2-QTS 10W30 FOR VECTOR MACH	118377	15.86
		I-574587	01 -540-0420-03	REPAIRS & MAI 2-BEARINGS FOR SCAGG MOWER	118377	30.98
		I-574599	01 -540-0420-04	REPAIRS & MAI 1-SWAY BAR REPAIR UNIT#52	118377	25.98
		I-574635	01 -540-0420-03	REPAIRS & MAI 2-ROLLER BALLBRNGS.	118377	15.96
		I-574636	01 -540-0420-04	REPAIRS & MAI CURVED RAD. RAD.HOSE #52	118377	42.29
		I-574638	01 -540-0420-04	REPAIRS & MAI 2-HOSECLAMPS	118377	2.52
		I-574692	01 -540-0420-01	REPAIRS & MAI 12 QTS EA.5W20/5W30	118377	73.68
		I-574917	01 -540-0420-03	REPAIRS & MAI BATTERY, ENV.CHG. WTR PUMP	118377	90.99
		I-575118	01 -540-0420-03	REPAIRS & MAI 3-SPRKPLUGS, WTRPMP	118377	16.32
		I-575119	01 -540-0420-03	REPAIRS & MAI CABLE TIES FUEL FILTER	118377	21.52
01-015012	O'REILLY AUTOMOTIVE, IN	C-400536	01 -540-0420-01	REPAIRS & MAI BRAKE ROTOR - RETURN	118380	168.18-
		C-400536	01 -540-0420-01	REPAIRS & MAI BRAKE ROTOR - EXCHANGE	118380	99.96
		I-402568	01 -540-0420-03	REPAIRS & MAI JUMPTSTART-RETURNED	118380	139.98-
		I-402568	01 -540-0420-03	REPAIRS & MAI JUMPTSTART -EXCHANGE	118380	159.98
01-015020	OIL PATCH FUEL & SUPPLY	I-317883	01 -540-0104	FUELS & LUBRI DIESEL FUEL DELIVERED 9/10/10	118381	1,273.43
01-016110	PADRE ISLAND'S ACE HARD	I-066369	01 -540-0420-04	REPAIRS & MAI UTILITY HOSE	118383	4.79

PACKET: 06930 AP CHECK RUN 10-01-10

VENDOR SET: 01

FUND : 01 GENERAL FUND

DEPARTMENT: 540 FLEET MANAGEMENT

BANK: OPER

BUDGET TO USE: CB-CURRENT BUDGET

VENDOR	NAME	ITEM #	G/L ACCOUNT NAME	DESCRIPTION	CHECK#	AMOUNT
01-016110	PADRE ISLAND'S ACE HARD		continued			
		I-066390	01 -540-0420-02	REPAIRS & MAI CAULK GUN, CAULK, GLUE, BULB	118383	16.06
		I-066393	01 -540-0420-03	REPAIRS & MAI 4-CLAMPS, COMPRESN UNION	118383	10.75
01-019310	SOUTH SHORE AUTOMOTIVE					
		I-3282	01 -540-0420-04	REPAIRS & MAI CE-52	118406	249.71
01-020200	TIPOTEX CHEVROLET INC.					
		I-402590	01 -540-0420-01	REPAIRS & MAI 1- SHIELD UNIT CO2PD	118418	25.04
01-020203	TIPTON MOTORS, INC					
		I-68029	01 -540-0420-01	REPAIRS & MAI 2-TPMS KITS UNIT F-91	118419	81.68
		I-68189	01 -540-0420-01	REPAIRS & MAI 1-CABLE ASY	118419	86.93
		I-68464	01 -540-0420-03	REPAIRS & MAI 1-ARM ASY UNIT CE 52	118419	96.58
				DEPARTMENT 540 FLEET MANAGEMENT	TOTAL:	5,197.26

PACKET: 06930 AP CHECK RUN 10-01-10

VENDOR SET: 01

FUND : 01 GENERAL FUND

DEPARTMENT: 541 BUILDING MAINTENANCE

BANK: OPER

BUDGET TO USE: CB-CURRENT BUDGET

VENDOR	NAME	ITEM #	G/L ACCOUNT NAME	DESCRIPTION	CHECK#	AMOUNT
01-002200	BLUE CROSS BLUE SHIELD	I-201009302799	01 -541-0081	GROUP INSURAN BLUE CROSS BLUE SHIELD	118308	79.65
01-006133	FORT DEARBORN LIFE INS	I-201009302805	01 -541-0081	GROUP INSURAN FORT DEARBORN LIFE INS CO	118347	1.36-
01-016098	PADRE ISLAND HEALTH SPE	I-201009302800	01 -541-0530	PROFESSIONAL 5 PANEL DRUG TEST :FEB. MARCH	118382	50.00
01-016110	PADRE ISLAND'S ACE HARD	I-066061	01 -541-0115	LAMPS & GLOBE 4-FLUOR BULBS. TRAINING CTR	118383	17.96
		I-066558	01 -541-0160	LAUNDRY & JAN PAINTBRUSH, MP GREASE, ETC.	118383	87.93
		I-066681	01 -541-0411	BUILDINGS & S DOOR HDW.	118383	5.60
		I-066820	01 -541-0150	MINOR TOOLS & MINOR TOOLS	118383	256.08
01-018056	RED WING SHOE STORE	I-850000003387	01 -541-0130	WEARING APPAR BOOTS FOR BUILDING MAINT.	118394	95.44
		I-850000003422	01 -541-0130	WEARING APPAR BOOTS FOR BUILDING MAINT.	118394	118.99
01-018504	SA-SO	I-6853A	01 -541-0150	MINOR TOOLS & OUTDOOR CONVEX MIRROR	118397	364.00
01-021102	UNIFIRST CORP.	I-1854895	01 -541-0130	WEARING APPAR UNIFORMS, AIR FRESHNERS, ETC	118428	34.84
		I-1854895	01 -541-0160	LAUNDRY & JAN UNIFORMS, AIR FRESHNERS, ETC	118428	85.76
		I-1857011	01 -541-0130	WEARING APPAR UNIFORMS, AIR FRSHNERS, ETC	118428	34.84
		I-1857011	01 -541-0160	LAUNDRY & JAN UNIFORMS, AIR FRSHNERS, ETC	118428	42.20
		I-1859125	01 -541-0130	WEARING APPAR UNIFORMS,AIR FRESHNERS, EC	118428	37.38
		I-1859125	01 -541-0160	LAUNDRY & JAN UNIFORMS,AIR FRESHNERS, EC	118428	96.24
01-023053	WALMART COMMUNITY	I-005443	01 -541-0160	LAUNDRY & JAN JANITORIAL SUPPLIES	118432	14.72
DEPARTMENT 541 BUILDING MAINTENANCE					TOTAL:	1,420.27

PACKET: 06930 AP CHECK RUN 10-01-10

VENDOR SET: 01

FUND : 01 GENERAL FUND

DEPARTMENT: 542 INSPECTIONS DIVISION

BANK: OPER

BUDGET TO USE: CB-CURRENT BUDGET

VENDOR	NAME	ITEM #	G/L ACCOUNT NAME	DESCRIPTION	CHECK#	AMOUNT
01-002200	BLUE CROSS BLUE SHIELD					
		I-201009302799	01 -542-0081	GROUP INSURAN BLUE CROSS BLUE SHIELD	118308	79.65
01-006133	FORT DEARBORN LIFE INS					
		I-201009302805	01 -542-0081	GROUP INSURAN FORT DEARBORN LIFE INS CO	118347	93.22
DEPARTMENT 542 INSPECTIONS DIVISION					TOTAL:	172.87

PACKET: 06930 AP CHECK RUN 10-01-10

VENDOR SET: 01

FUND : 01 GENERAL FUND

DEPARTMENT: 543 PUBLIC WORKS DEPARTMENT

BANK: OPER

BUDGET TO USE: CB-CURRENT BUDGET

VENDOR	NAME	ITEM #	G/L ACCOUNT NAME	DESCRIPTION	CHECK#	AMOUNT
01-001101	ACE PARKING LOT SERVICE	I-3753	01 -543-0416	STREETS & RIG STRIPING	118294	895.00
01-001200	L.R.G.V.D.C.	I-001	01 -543-0513	TRAINING EXPE GIS/GPS TRAINING	118296	200.00
01-002200	BLUE CROSS BLUE SHIELD	I-201009302799	01 -543-0081	GROUP INSURAN BLUE CROSS BLUE SHIELD	118308	477.90
01-002700	BURTON AUTO SUPPLY, INC	I-03 905022	01 -543-0410	MACHINERY & E 14 MISC.GASKETS.	118313	8.58
01-002856	RENTAL WORLD	C-04-044521-01	01 -543-0510	RENTAL OF EQU CORRECTED INVOICE RECEIVED	118315	40.00-
		I-04-044521-01	01 -543-0510	RENTAL OF EQU 1-TAMPER, VIBRO PLATESTD	118315	40.00
		I-04-044521-02	01 -543-0510	RENTAL OF EQU RENTAL OF VIBROPLATETAMPER	118315	46.67
01-003410	CHAMBER OF COMMERCE - S	I-91610	01 -543-0551	DUES & MEMBER QTRLY LUNCHEON: SCOTT FRY	118330	18.00
01-003760	CONSOLIDATED ELECTRICAL	I-0938-470142	01 -543-0412	LANDSCAPE LIGHTS FOR CENTER MED.	118336	483.00
01-006043	LOS FRESNOS CONSTRUCTIO	I-720	01 -543-0416	STREETS & RIG 1 LOAD CALICHE	118342	500.00
		I-723	01 -543-0416	STREETS & RIG PK UP & DELIVER COLD MIX	118342	500.00
01-006133	FORT DEARBORN LIFE INS	I-201009302805	01 -543-0081	GROUP INSURAN FORT DEARBORN LIFE INS CO	118347	462.64
01-006159	SCOTT FRY	I-82510	01 -543-0550	TRAVEL EXPENS MILEAGE REIMBURSEMENT	118349	62.00
		I-90210	01 -543-0550	TRAVEL EXPENS MILEAGE REIMBURSEMENT	118349	62.00
01-007029	GE CAPITAL	I-92710	01 -543-0410	MACHINERY & E SETTLEMENT ON COPIER LEASE	118292	2,500.00
01-007399	GRAINGER	I-9338091326	01 -543-0150	MINOR TOOLS & LOCKERS FOR PW CREW	118355	798.82
01-012071	LAGUNA MDRE WTR DIST NO	I-092310-01	01 -543-0416	STREETS & RIG EMERGENCY CLEANING OF DRAINS	118369	600.00
01-013114	MATHESON TRI-GAS	I-01709657	01 -543-0510	RENTAL OF EQU MISC. WELDING SUPPLIES	118372	108.02
01-016098	PADRE ISLAND HEALTH SPE	I-201009302800	01 -543-0530	PROFESSIONAL 5 PANEL DRUG TEST :FEB. MARCH	118382	125.00
		I-201009302801	01 -543-0530	PROFESSIONAL 5-PANEL DRUG TEST :FEB MARCH	118382	25.00

PACKET: 06930 AP CHECK RUN 10-01-10

VENDOR SET: 01

FUND : 01 GENERAL FUND

DEPARTMENT: 543 PUBLIC WORKS DEPARTMENT

BANK: OPER

BUDGET TO USE: CB-CURRENT BUDGET

VENDOR	NAME	ITEM #	G/L	ACCOUNT NAME	DESCRIPTION	CHECK#	AMOUNT
01-016110	PADRE ISLAND'S ACE HARD						
		I-066029	01	-543-0412	LANDSCAPE DUCT TAPE,WIRE ROPE CLIPS	118383	12.45
		I-066137	01	-543-0150	MINOR TOOLS & EYE BOLTS,NUTS TURNBKLE,ETC	118383	30.73
		I-066148	01	-543-0150	MINOR TOOLS & 2-ANCHOR SHACKLES	118383	10.98
		I-066176	01	-543-0150	MINOR TOOLS & NUTS BOLTS, EYE BOLT	118383	5.09
		I-066241	01	-543-0410	MACHINERY & E MISC.HDW FOR TRACTOR #13	118383	4.96
		I-066631	01	-543-0150	MINOR TOOLS & SANDBELT FOR SHOPUSE	118383	4.49
		I-066649	01	-543-0150	MINOR TOOLS & PLIERS AND DRILL BITS	118383	29.98
		I-066649	01	-543-0150	MINOR TOOLS & ACE REWARDS CARD	118383	25.00-
		I-066650	01	-543-0150	MINOR TOOLS & HDW FOR MIRROR INSTALLATION	118383	5.56
		I-066812	01	-543-0150	MINOR TOOLS & ANT KILLER, BARREL BOLT,	118383	41.74
01-016302	PINKERTON MEMORIALS						
		I-81310	01	-543-0412	LANDSCAPE	118389	2,400.00
01-019100	SEA GARDEN SALES						
		I-1349495	01	-543-0150	MINOR TOOLS & 1 CS ASST.SQWINCHER DRINK	118400	98.89
		I-1350262	01	-543-0412	LANDSCAPE HOT ROLLED STRIP, FLAT BAR	118400	40.68
01-019101	SEARS COMMERCIAL ONE						
		I-T232571	01	-543-0150	MINOR TOOLS & SOCKET SET	118401	117.98
01-019210	SMITH MUNICIPAL SUPPLIE						
		I-00-11136	01	-543-0112	SIGNS "DIP"SIGN	118402	60.84
01-021102	UNIFIRST CORP.						
		I-1854895	01	-543-0130	WEARING APPAR UNIFORMS, AIR FRESHNERS, ETC	118428	209.23
		I-1857011	01	-543-0130	WEARING APPAR UNIFORMS, AIR FRSHNERS, ETC	118428	202.44
		I-1859125	01	-543-0130	WEARING APPAR UNIFORMS,AIR FRESHNERS, EC	118428	220.02
01-023100	WHITE LUMBER & SUPPLY I						
		I-143413	01	-543-0112	SIGNS 5-80#BGS CONCRETE MIX.	118436	23.60
		I-144229	01	-543-0150	MINOR TOOLS & 1-DEADBOLT, RE-KEY LOCK	118436	21.49
		I-145760	01	-543-0412	LANDSCAPE POLY TUBING, CONN, NIPPLE	118436	5.27
01-024202	ZIMCO MARINE, INC.						
		I-0063517-IN	01	-543-0150	MINOR TOOLS & GALV. PIPE, THREAD PIPE, CAP	118441	53.83

DEPARTMENT 543 PUBLIC WORKS DEPARTMENT TOTAL: 11,447.88

PACKET: 06930 AP CHECK RUN 10-01-10

VENDOR SET: 01

FUND : 01 GENERAL FUND

DEPARTMENT: 570 GENERAL SERVICES

BANK: OPER

BUDGET TO USE: CB-CURRENT BUDGET

VENDOR	NAME	ITEM #	G/L ACCOUNT NAME	DESCRIPTION	CHECK#	AMOUNT
01-001129	A & W OFFICE SUPPLY INC					
		I-436462-0	01 -570-9174	RECORDS MANAG SHELVING/FRAMES	118295	387.46
		I-436462-0	01 -570-9174	RECORDS MANAG SHELVING	118295	386.85
		I-436462-0	01 -570-9174	RECORDS MANAG SHELVING	118295	46.35
		I-438296-0	01 -570-0101	OFFICE SUPPLI COPY PAPER	118295	475.86
01-002106	BICKERSTAFF HEATH DELGA					
		I-78494	01 -570-9030	LEGAL SERVICE PROF.SERVICES THRU SEPT.15	118306	70.00
01-002805	ALLIED WASTE SERVICES #					
		I-0863000402452	01 -570-0581	WATER, SEWER, 108 W. RETAMA ST.	118314	1,399.82
01-009159	IKON OFFICE SOLUTIONS					
		I-82482056-1	01 -570-0510	RENTAL OF EQU COPIER LEASE FY2009-10	118362	243.51
01-020602	TOUCAN GRAPHICS					
		I-10818	01 -570-0118	PRINTING 250 BUS. CARDS:B. BASKETT	118423	30.00
01-022000	VALLEY BOTTLE WATER CO.					
		C-828312	01 -570-0581	WATER, SEWER, BOTTLED WTER	118430	35.75-
		I-828313	01 -570-0581	WATER, SEWER, BOTTLED WATER PUBLIC WRKS	118430	41.25
		I-828314	01 -570-0581	WATER, SEWER, BOTTLED WATER FIRE DEPT	118430	62.50
		I-828315	01 -570-0581	WATER, SEWER, BOTTLED WATER P WRKS	118430	84.75
		I-838779	01 -570-0581	WATER, SEWER, BOTTLED WATER PUBLIC WRKS	118430	77.75
		I-838780	01 -570-0581	WATER, SEWER, BOTTLED WATER PUBLIC WRKS	118430	38.75
		I-838781	01 -570-0581	WATER, SEWER, BOTTLED WATER P WRKS	118430	29.00
		I-838782	01 -570-0581	WATER, SEWER, BOTTLED WATER FIRE DPT	118430	35.50
01-023053	WALMART COMMUNITY					
		I-001577	01 -570-0101	OFFICE SUPPLI RPL DECANTER FOR COFFEE MKR	118432	13.74
DEPARTMENT 570 GENERAL SERVICES					TOTAL:	3,387.34

PACKET: 06930 AP CHECK RUN 10-01-10

VENDOR SET: 01

FUND : 01 GENERAL FUND

DEPARTMENT: 572 SPECIAL PROJECTS

BANK: OPER

BUDGET TO USE: CB-CURRENT BUDGET

VENDOR	NAME	ITEM #	G/L ACCOUNT NAME	DESCRIPTION	CHECK#	AMOUNT
01-013259	MINI-STOR ALL					
		I-8069	01 -572-9179	HOLIDAY LIGHT X-MAS STORAGE UNIT	118374	83.00
				DEPARTMENT 572 SPECIAL PROJECTS	TOTAL:	83.00
			FUND 01	GENERAL FUND	TOTAL:	45,887.68

PACKET: 06930 AP CHECK RUN 10-01-10

VENDOR SET: 01

FUND : 02 HOTEL/MOTEL TAX FUND

DEPARTMENT: N/A NON-DEPARTMENTAL

BANK: OPER

BUDGET TO USE: CB-CURRENT BUDGET

VENDOR	NAME	ITEM #	G/L ACCOUNT NAME	DESCRIPTION	CHECK#	AMOUNT
01-014021	NBA DEVELOPEMENT LEAGUE	I-92910	02 -1400	PREPAID EXPEN NBADL EXPENSES /TICKET SALES	118376	75,000.00
01-019018	SAND CASTLE DAYS, INC	I-92810	02 -1400	PREPAID EXPEN 2010 EVENT SPONSORSHIP	118399	35,000.00
01-019238	SPI BIKEFEST, INC.	I-92810	02 -1400	PREPAID EXPEN 2010 EVENT SPONSORSHIP	118403	15,000.00
				DEPARTMENT	NON-DEPARTMENTAL	TOTAL: 125,000.00

PACKET: 06930 AP CHECK RUN 10-01-10

VENDOR SET: 01

FUND : 02 HOTEL/MOTEL TAX FUND

DEPARTMENT: 590 VISITORS BUREAU

BANK: OPER

BUDGET TO USE: CB-CURRENT BUDGET

VENDOR	NAME	ITEM #	G/L ACCOUNT NAME	DESCRIPTION	CHECK#	AMOUNT
01-001210	AIR FILTER COMPANY					
		I-0000051265	02 -590-0411	BUILDINGS & S AIR FILTER SERV. V. CTR	118297	24.00
01-002200	BLUE CROSS BLUE SHIELD					
		I-201009302799	02 -590-0081	GROUP INSURAN BLUE CROSS BLUE SHIELD	118308	53.10
01-006133	FORT DEARBORN LIFE INS					
		I-201009302805	02 -590-0081	GROUP INSURAN FORT DEARBORN LIFE INS CO	118347	53.69
01-007600	GULF COAST PAPER CO. IN					
		I-65572	02 -590-0160	LAUNDRY & JAN MISC. JANITORIAL SUPPLIES	118356	85.10
		I-67334	02 -590-0160	LAUNDRY & JAN 1 CS. WASHROOM CLEANER	118356	25.33
01-016110	PADRE ISLAND'S ACE HARD					
		I-066398	02 -590-0411	BUILDINGS & S ROOF NAILS, ,COM. NAILS, BUNGE	118383	9.77
		I-066448	02 -590-0150	MINOR TOOLS & SILICONE CAULK, NAILS	118383	11.98
		I-066450	02 -590-0411	BUILDINGS & S 3-2X4X8' STUDS	118383	20.97
		I-066515	02 -590-0411	BUILDINGS & S 3-WET ROOF PATCH	118383	8.97
		I-066770	02 -590-0150	MINOR TOOLS & SILICONE CAULK, SANDPAPER	118383	8.97
01-020104	TEXAS APPROACH/GROUP TE					
		I-49	02 -590-0108	POSTAGE VISITOR INFO REQ. AUG 2010	118416	3,787.82
		I-50	02 -590-0108	POSTAGE POSTAL ACCOUNT FORAUG2010	118416	7,982.18
01-020661	TOP CUT LAWN CARE & IRR					
		I-29990	02 -590-0412	LANDSCAPE LAWN CARE SERVICE	118425	375.00
01-021102	UNIFIRST CORP.					
		I-0000648239380	02 -590-0108	POSTAGE WEEKLY SERVICE CHG	118428	20.00
		I-1854896	02 -590-0160	LAUNDRY & JAN FLOOR MATS, ETC - VISITOR CTR	118428	38.15
		I-1859126	02 -590-0160	LAUNDRY & JAN FLOORMATS, VISITORS CTR	118428	40.40
01-022000	VALLEY BOTTLE WATER CO.					
		I-828319	02 -590-0581	WATER, SEWER & BOTTLED WATER VISITOR CTRE	118430	11.50
01-023053	WALMART COMMUNITY					
		I-005272	02 -590-0420	MOTOR VEHICLE OIL CHANGE VISITOR CTR UNIT	118432	36.88
DEPARTMENT 590 VISITORS BUREAU					TOTAL:	12,593.81

PACKET: 06930 AP CHECK RUN 10-01-10

VENDOR SET: 01

FUND : 02 HOTEL/MOTEL TAX FUND

DEPARTMENT: 592 SALES & MARKETING

BANK: OPER

BUDGET TO USE: CB-CURRENT BUDGET

VENDOR	NAME	ITEM #	G/L ACCOUNT NAME	DESCRIPTION	CHECK#	AMOUNT
01-001216	AJR MEDIA GROUP	I-231996	02 -592-0533	MARKETING REPRESENTATION, EMAIL, TARGETMSG	118298	679.08
01-002200	BLUE CROSS BLUE SHIELD	I-201009302799	02 -592-0081	GROUP INSURAN BLUE CROSS BLUE SHIELD	118308	265.50
01-003441	CLEAN PIX CORP.	I-5790	02 -592-0530	PROFESSIONAL MANAGED SERV.8/11-5/14/111	118333	375.00
01-004297	EL NORTE	I-95527	02 -592-0531	MEDIA PLACEME ADS FOR SEPT.16,	118340	5,350.00
01-006133	FORT DEARBORN LIFE INS	I-201009302805	02 -592-0081	GROUP INSURAN FORT DEARBORN LIFE INS CO	118347	321.66
01-009206	ISLAND EQUESTRIAN CENTE	I-91610	02 -592-0535	FAMILIARIZATI BROWNSVILLE AIRPORT FAM TOUR	118364	30.00
01-019253	SYLVIA SOLIZ	I-91510	02 -592-0550	TRAVEL EXPENS MILEAGE REIMBURSEMENT	118405	131.50
01-019510	AT&T ADVERTISING & PUBL	I-091110	02 -592-0531	MEDIA PLACEME YELLOW PAGE ADVERTISING	118407	256.40
01-020052	TEXAS TRAVEL INDUSTRY A	I-7166	02 -592-0513	TRAINING EXPE TTIA REGISTRATION	118413	270.00
01-020073	TEXAS HOTEL & LODGING A	I-010-1690	02 -592-0550	TRAVEL EXPENS TRAVEL REINBURSEMENT	118415	194.20
01-023152	WINDSURF INC.	I-92410	02 -592-0535	FAMILIARIZATI LESSONS FOR TRAVELWRITER	118437	90.00
DEPARTMENT 592 SALES & MARKETING					TOTAL:	7,963.34

PACKET: 06930 AP CHECK RUN 10-01-10

VENDOR SET: 01

FUND : 02 HOTEL/MOTEL TAX FUND

DEPARTMENT: 593 EVENTS MARKETING

BANK: OPER

BUDGET TO USE: CB-CURRENT BUDGET

VENDOR	NAME	ITEM #	G/L ACCOUNT NAME	DESCRIPTION	CHECK#	AMOUNT
01-002200	BLUE CROSS BLUE SHIELD	I-201009302799	02 -593-0081	GROUP INSURAN BLUE CROSS BLUE SHIELD	118308	26.55
01-006133	FORT DEARBORN LIFE INS	I-201009302805	02 -593-0081	GROUP INSURAN FORT DEARBORN LIFE INS CO	118347	33.10
DEPARTMENT 593 EVENTS MARKETING					TOTAL:	59.65
FUND 02 HOTEL/MOTEL TAX FUND					TOTAL:	145,616.80

PACKET: 06930 AP CHECK RUN 10-01-10

VENDOR SET: 01

FUND : 06 CONVENTION CENTER FUND

DEPARTMENT: 565 CONVENTION CENTER OPER

BANK: OPER

BUDGET TO USE: CB-CURRENT BUDGET

VENDOR	NAME	ITEM #	G/L ACCOUNT NAME	DESCRIPTION	CHECK#	AMOUNT
01-001014	ADMIRAL LINEN & UNIFORM					
		I-SE01529	06 -565-0160	LAUNDRY & JAN MOPS, AIR FRESHNERS, ETC	118293	43.00
		I-SE01530	06 -565-0510	RENTAL OF EQU MISC. TABLECOVERS	118293	42.10
		I-SE92975	06 -565-0160	LAUNDRY & JAN MOPS, AIR FRESHNERS, ETC	118293	43.00
		I-SE92976	06 -565-0510	RENTAL OF EQU MISC. TABLECOVERS	118293	323.75
		I-SE96905	06 -565-0160	LAUNDRY & JAN MOPS, AIR FRESHNERS, ETC	118293	43.00
		I-SE96906	06 -565-0510	RENTAL OF EQU MISC. TABLECOVERS	118293	745.75
01-002052	BEN E. KEITH, CO.					
		I-01821614	06 -565-0176	CONCESSION SU MISC. CONCESSOIN SUPPLIES	118304	1,657.55
		I-01833148	06 -565-0176	CONCESSION SU MISC. CONCESSION SUPPLIES	118304	1,105.42
01-002200	BLUE CROSS BLUE SHIELD					
		I-201009302799	06 -565-0081	GROUP INSURAN BLUE CROSS BLUE SHIELD	118308	265.50
01-002805	ALLIED WASTE SERVICES #					
		I-0863000402416	06 -565-0581	WATER, SEWER 7355 PADRE BLVD-BORDERBASH	118314	290.52
01-003419	C & S SAFETY SUPPLY					
		I-113002	06 -565-0114	MEDICAL MISC. FIRST AID SUPPLIES	118331	42.07
		I-113421	06 -565-0114	MEDICAL MISC. FIRST AID SUPPLIES	118331	47.64
		I-113954	06 -565-0114	MEDICAL MISC. FIRST AID SUPPLIES	118331	48.03
01-006133	FORT DEARBORN LIFE INS					
		I-201009302805	06 -565-0081	GROUP INSURAN FORT DEARBORN LIFE INS CO	118347	239.49
01-007600	GULF COAST PAPER CO. IN					
		I-71822	06 -565-0160	LAUNDRY & JAN JANITORIAL SUPPLIES	118356	271.80
01-008227	HINO GAS SALES, INC.					
		I-402552	06 -565-0581	WATER, SEWER 17 GALS. LPG DELIVERED	118358	57.80
01-012020	THE LIGHT HOUSE					
		I-P41472	06 -565-0115	LAMPS & GLOBE 1-LIGHT FOR WHALEN WALL	118368	96.75
01-016098	PADRE ISLAND HEALTH SPE					
		I-201009302801	06 -565-0530	PROFESSIONAL 5-PANEL DRUG TEST :FEB MARCH	118382	25.00
01-016110	PADRE ISLAND'S ACE HARD					
		I-066454	06 -565-0160	LAUNDRY & JAN 4-INSECT REPELLANT	118383	21.96
01-019310	SOUTH SHORE AUTOMOTIVE					
		I-3235	06 -565-0420	MOTOR VEHICLE STATE INSPECTION VAN	118406	14.50
01-020221	STEVEN HYDE					
		I-091210	06 -565-0411	BUILDING & ST SPRINKLER SYSTEM REPAIR	118421	359.53
		I-91810	06 -565-0415	SERVICE CONTR IRRIGATION SYSTEM SERVICE	118421	330.00
01-022000	VALLEY BOTTLE WATER CO.					

PACKET: 06930 AP CHECK RUN 10-01-10

VENDOR SET: 01

FUND : 06 CONVENTION CENTER FUND

DEPARTMENT: 565 CONVENTION CENTER OPER

BANK: OPER

BUDGET TO USE: CB-CURRENT BUDGET

VENDOR	NAME	ITEM #	G/L ACCOUNT NAME	DESCRIPTION	CHECK#	AMOUNT			

01-022000	VALLEY BOTTLE WATER CO.		continued						
		I-828311	06 -565-0581	WATER, SEWER BOTTLED WATER CVB	118430	45.50			
		I-838778	06 -565-0581	WATER, SEWER BOTTLED WATER CVB	118430	22.50			
					DEPARTMENT 565	CONVENTION CENTER OPER	TOTAL:	6,182.16	

					FUND	06	CONVENTION CENTER FUND	TOTAL:	6,182.16

PACKET: 06930 AP CHECK RUN 10-01-10

VENDOR SET: 01

FUND : 21 MUN. COURT TECHNOLOGY

DEPARTMENT: 520 MUN COURT TECHNOLOGY

BANK: OPER

BUDGET TO USE: CB-CURRENT BUDGET

VENDOR	NAME	ITEM #	G/L ACCOUNT NAME	DESCRIPTION	CHECK#	AMOUNT
01-009103	INCODE					
		I-2452	21 -520-0150	MINOR TOOLS & CREDIT CARD SWIPERS	118361	170.00
				DEPARTMENT 520 MUN COURT TECHNOLOGY	TOTAL:	170.00
				FUND 21 MUN. COURT TECHNOLOGY	TOTAL:	170.00

PACKET: 06930 AP CHECK RUN 10-01-10

VENDOR SET: 01

FUND : 30 TRANSPORTAION GRANT

DEPARTMENT: 591 TRANSPORTATION DEPT

BANK: OPER

BUDGET TO USE: CB-CURRENT BUDGET

VENDOR	NAME	ITEM #	G/L ACCOUNT NAME	DESCRIPTION	CHECK#	AMOUNT			
01-001129	A & W OFFICE SUPPLY INC								
		I-436011-0	30 -591-0101	OFFICE SUPPLI MISC DRY ERASE MARKERS	118295	25.39			
		I-436026-0	30 -591-0101	OFFICE SUPPLI 1- HP BLK INK CARTRIDGE	118295	77.99			
01-002196	BLANCO'S DETAILING SERV								
		I-92410	30 -591-0420	MOTOR VEHICLE WASH & DETAIL BUSES-	118307	240.00			
01-002200	BLUE CROSS BLUE SHIELD								
		I-201009302799	30 -591-0081	GROUP INSURAN BLUE CROSS BLUE SHIELD	118308	238.95			
01-002435	BOGGUS MOTOR COMPANY								
		I-C46463	30 -591-0420	MOTOR VEHICLE CHECK ENG. LIGHT, ETC. E-450	118312	92.00			
01-004297	EL NORTE								
		I-489339	30 -591-0540	ADVERTISING 2 FULL COLOR PAGE ADS	118340	300.00			
		I-489340	30 -591-0540	ADVERTISING 2 FULL COLOR PAGE ADS	118340	300.00			
01-006083	FAST & FAIR CAR CARE								
		I-1322	30 -591-0420	MOTOR VEHICLE 13 TIRES RECYCLED	118343	65.00			
		I-1324	30 -591-0420	MOTOR VEHICLE 24 TIRES RECYCLED	118343	124.00			
01-006101	FIRST CHECK APPLICANT S								
		I-11454	30 -591-0530	PROFESSIONAL PRE-EMPLOYMENT SCREENING	118345	21.25			
01-006133	FORT DEARBORN LIFE INS								
		I-201009302805	30 -591-0081	GROUP INSURAN FORT DEARBORN LIFE INS CO	118347	221.36			
01-015012	O'REILLY AUTOMOTIVE, IN								
		I-402552	30 -591-0420	MOTOR VEHICLE 1-TIE ROD END	118380	48.83			
		I-402771	30 -591-0420	MOTOR VEHICLE 24 QTS.MOTOR OIL	118380	54.96			
01-016110	PADRE ISLAND'S ACE HARD								
		I-066933	30 -591-0420	MOTOR VEHICLE WIRE BRUSH, WIPING CLOTHS, ETC	118383	23.76			
01-020203	TIPTON MOTORS, INC								
		I-68152	30 -591-0420	MOTOR VEHICLE 1-CABLE ASY	118419	58.00			
		I-68350	30 -591-0420	MOTOR VEHICLE 1-ROD ASY UNIT #28	118419	126.00			
01-021153	RICK M. VASQUEZ								
		I-92210	30 -591-0550	TRAVEL EXPENS MISC.REIMBURSEMENT	118429	18.00			
					DEPARTMENT 591	TRANSPORTATION DEPT	TOTAL:	2,035.49	
					FUND	30	TRANSPORTAION GRANT	TOTAL:	2,035.49

PACKET: 06930 AP CHECK RUN 10-01-10

VENDOR SET: 01

FUND : 60 BEACH MAINTENANCE FUND

DEPARTMENT: 522 BEACH PATROL / PT TIME

BANK: OPER

BUDGET TO USE: CB-CURRENT BUDGET

VENDOR	NAME	ITEM #	G/L ACCOUNT NAME	DESCRIPTION	CHECK#	AMOUNT
01-016609	PORT SUPPLY	I-9430472	60 -522-1004	MACHINERY & E MISC. SUPPLIES - BEACH	118391	723.50
DEPARTMENT 522 BEACH PATROL / PT TIME					TOTAL:	723.50

PACKET: 06930 AP CHECK RUN 10-01-10

VENDOR SET: 01

FUND : 60 BEACH MAINTENANCE FUND

DEPARTMENT: 560 BEACH MAINTENANCE

BANK: OPER

BUDGET TO USE: CB-CURRENT BUDGET

VENDOR	NAME	ITEM #	G/L	ACCOUNT NAME	DESCRIPTION	CHECK#	AMOUNT
01-001200	L.R.G.V.D.C.						
		I-001	60	-560-0513	TRAINING GIS/GPS TRAINING	118296	200.00
01-002200	BLUE CROSS BLUE SHIELD						
		I-201009302799	60	-560-0081	GROUP INSURAN BLUE CROSS BLUE SHIELD	118308	106.20
01-003221	CAROLINA BIOLOGICAL SUP						
		I-47423632RI	60	-560-0150	MINOR TOOLS & EQUIPMENT	118328	2,439.73
		I-47432847RI	60	-560-0150	MINOR TOOLS & EQUIPMENT	118328	17.53
		I-47434265RI	60	-560-0150	MINOR TOOLS & EQUIPMENT	118328	17.05
		I-47440996RI	60	-560-0150	MINOR TOOLS & EQUIPMENT	118328	15.63
		I-47442946RI	60	-560-0150	MINOR TOOLS & EQUIPMENT	118328	12.08
01-006133	FORT DEARBORN LIFE INS						
		I-201009302805	60	-560-0081	GROUP INSURAN FORT DEARBORN LIFE INS CO	118347	25.22
01-007600	GULF COAST PAPER CO. IN						
		I-906518	60	-560-0510	EXCESS BEACH 6 CS.DRUMLINERS	118356	87.84
01-014109	NUECES POWER EQUIPMENT						
		I-PB83349	60	-560-0510	EXCESS BEACH 1-ELBOW & BELT UNIT #13	118379	28.51
01-016098	PADRE ISLAND HEALTH SPE						
		I-201009302800	60	-560-0530	PROFESSIONAL 5 PANEL DRUG TEST :FEB. MARCH	118382	25.00
01-016110	PADRE ISLAND'S ACE HARD						
		I-065987	60	-560-0150	MINOR TOOLS & 2-100 FT POLY ROPES	118383	19.98
		I-066138	60	-560-0510	EXCESS BEACH HINGE AND MISC HDW	118383	27.87
		I-066619	60	-560-0510	EXCESS BEACH 8 MISC.HDW, TREASURE ISLAND	118383	3.20
		I-066765	60	-560-0510	EXCESS BEACH MISC.HDW.MOWER CORD	118383	4.55
DEPARTMENT 560 BEACH MAINTENANCE						TOTAL:	3,030.39

FUND 60 BEACH MAINTENANCE FUND						TOTAL:	3,753.89

PACKET: 06930 AP CHECK RUN 10-01-10

VENDOR SET: 01

FUND : 80 ECONOMIC DEVELOPMENT CORP

DEPARTMENT: N/A NON-DEPARTMENTAL

BANK: OPER

BUDGET TO USE: CB-CURRENT BUDGET

VENDOR	NAME	ITEM #	G/L ACCOUNT NAME	DESCRIPTION	CHECK#	AMOUNT		
01-001404	ATLAS SCREEN PRINTING	I-145343	80 -1401	GIFT SHOP INV EDC/SPIBNC:MUGS FOR GIFT SHOP	118303	111.16		
01-003859	COMMON GROUND DISTRIBUT	I-446212	80 -1401	GIFT SHOP INV EDC/SPIBNC:BOOKS-GIFT SHOP	118338	550.70		
01-016132	PEGGY PARIS	I-92710	80 -1401	GIFT SHOP INV EDC/SPIBNC:GIFT SHOP ITEMS	118387	75.00		
01-018280	DOOLIE RULE	I-92810	80 -1401	GIFT SHOP INV EDC/SPIBNC:GIFT SHOP NOTE CARD	118396	105.00		
					DEPARTMENT	NON-DEPARTMENTAL	TOTAL:	841.86

PACKET: 06930 AP CHECK RUN 10-01-10

VENDOR SET: 01

FUND : 80 ECONOMIC DEVELOPMENT CORP

DEPARTMENT: 580 EDC

BANK: OPER

BUDGET TO USE: CB-CURRENT BUDGET

VENDOR	NAME	ITEM #	G/L ACCOUNT NAME	DESCRIPTION	CHECK#	AMOUNT
01-002200	BLUE CROSS BLUE SHIELD					
		I-201009302799	80 -580-0081	GROUP INSURAN BLUE CROSS BLUE SHIELD	118308	26.55
01-003700	NIELSEN LLC, CLARITAS					
		I-1770133	80 -580-0107	BOOKS & PUBLI EDC: ANNUAL DEMOGRAPHICS	118335	220.00
01-008179	HDR ENGINEERING INC.					
		I-00229962-H	80 -580-0534-018	MARINE SCIENC EDC'PROF.SERVICES	118357	1,411.14
01-008261	HILTON GARDEN INN					
		I-91410	80 -580-0550	TRAVEL EDC:LODGING FOR CANDIDATES	118359	644.49
01-009662	JONES & COOK STATIONERS					
		I-3152751-0	80 -580-0101	OFFICE SUPPLI EDC/SPIBNC:OFFICE SUPPLIES	118366	67.98
		I-3161727-0	80 -580-0101	OFFICE SUPPLI EDC:MISC. OFFICE SUPPLIES	118366	53.92
DEPARTMENT 580 EDC					TOTAL:	2,424.08

PACKET: 06930 AP CHECK RUN 10-01-10

VENDOR SET: 01

FUND : 80 ECONOMIC DEVELOPMENT CORP

DEPARTMENT: 581 BIRDING CENTER

BANK: OPER

BUDGET TO USE: CB-CURRENT BUDGET

VENDOR	NAME	ITEM #	G/L ACCOUNT NAME	DESCRIPTION	CHECK#	AMOUNT
01-001349	ARGUS SECURITY SYSTEMS	I-17815582	80 -581-0415	SERVICE CONTR EDC/SPIBNC:FIRE EXT. INSPECTIO	118301	82.75
01-005511	EXTREME PEST CONTROL	I-0914103	80 -581-0415	SERVICE CONTR EDC/SPIBNC:PEST CONTROL	118341	78.00
01-007600	GULF COAST PAPER CO. IN	C-71074	80 -581-0590	JANITORIAL EDC:MERCHANDISE RETURNED	118356	45.35-
		I-66682	80 -581-0590	JANITORIAL EDC/SPIBNC:SUPPLIES BRK ROOM	118356	259.45
		I-70099	80 -581-0590	JANITORIAL EDC/SPIBNC:JANITORIAL SUPPLIES	118356	107.70
01-009195	ISLAND PLUMBING	I-92210	80 -581-0415	SERVICE CONTR EDC/SPIBNC:PLUMBING WRK	118363	75.00
01-009662	JONES & COOK STATIONERS	I-3152751-0	80 -581-0101	OFFICE SUPPLI EDC/SPIBNC:OFFICE SUPPLIES	118366	19.28
01-016110	PADRE ISLAND'S ACE HARD	I-066841	80 -581-0590	JANITORIAL EDC/SPIBNC:FILTERS	118383	50.03
		I-066843	80 -581-0590	JANITORIAL EDC/BNC:FILTERS/FLOODLAMPS	118383	15.48
01-018058	RELIABLE ELECTRIC CO.	I-23475	80 -581-0415	SERVICE CONTR EDC/SPIBNC:REPAIRS	118395	170.00
01-020063	TEXAS DEPT OF LICENSING	I-32662	80 -581-0415	SERVICE CONTR EDC/SPIBNC: ANNUAL FEE	118414	20.00
01-020222	GREEN THUMB LANDSCAPING	I-14490	80 -581-0415	SERVICE CONTR EDC/SPIBNC:CLEAND UP	118422	300.00
01-020602	TOUCAN GRAPHICS	I-10826	80 -581-0540	ADVERTISING EDC/SPIBNC:BIRDING CTR FLYERS	118423	95.00
01-021095	UNITED PARCEL SERVICE	I-000F7W657380	80 -581-0108	POSTAGE EDC/SPIBNC:MISC. SHIPPING CHG	118427	45.34
01-022153	VALLEY SANITARY SUPPLY,	I-5761	80 -581-0590	JANITORIAL EDC/SPIBNC:JANITORIALSUPPLIES	118431	43.84
01-023083	WELLS FARGO FINANCIAL L	I-6745725222	80 -581-0415	SERVICE CONTR EDC/SPIBNC:COPIER LEASE	118435	154.37
					DEPARTMENT 581 BIRDING CENTER	TOTAL: 1,470.89
					FUND 80 ECONOMIC DEVELOPMENT CORP	TOTAL: 4,736.83

PACKET: 06930 AP CHECK RUN 10-01-10

VENDOR SET: 01

FUND : 81 BEACH NOURISHMENT

DEPARTMENT: 581 BEACH RENOURISHMENT

BANK: OPER

BUDGET TO USE: CB-CURRENT BUDGET

VENDOR	NAME	ITEM #	G/L ACCOUNT NAME	DESCRIPTION	CHECK#	AMOUNT
01-008179	HDR ENGINEERING INC.	I-228208-H	81 -581-0530	PROFESSIONAL PROF.SERVI MARCH 28-AUG 28	118357	1,712.86
				DEPARTMENT 581 BEACH RENOURISHMENT	TOTAL:	1,712.86
				FUND 81 BEACH NOURISHMENT	TOTAL:	1,712.86

PACKET: 06930 AP CHECK RUN 10-01-10

VENDOR SET: 01

FUND : 85 BIRDING CENTER CONSTRUCTI

DEPARTMENT: 580 ** INVALID DEPT **

BANK: OPER

BUDGET TO USE: CB-CURRENT BUDGET

VENDOR	NAME	ITEM #	G/L ACCOUNT NAME	DESCRIPTION	CHECK#	AMOUNT
01-019635	SUPERIOR ALARMS					
		I-82510	85 -580-1001	BUILDINGS & S EDC/SPIBNC: ACCESS EQUIPMENT	118408	12,235.97
01-019697	SURFSIDE SIGNS & DESIGN					
		I-1130	85 -580-1001	BUILDINGS & S EDC/SPIBNC:SIGNS FOR BIRDING	118409	62.79
				DEPARTMENT 580 ** INVALID DEPT **	TOTAL:	12,298.76
				FUND 85 BIRDING CENTER CONSTRUCTI	TOTAL:	12,298.76
					REPORT GRAND TOTAL:	222,394.47

**CITY OF SOUTH PADRE ISLAND
CITY COUNCIL WORKSHOP
AGENDA REQUEST FORM**

MEETING DATE: October 6, 2010

NAME/DEPT.: Susan Hill, City Secretary

ITEM

Approve Lease Agreement for the use of one AutoMark (Voter Assist Terminal) during the November 2, 2010 Special Election.

ITEM BACKGROUND

RECOMMENDATIONS/COMMENTS

BUDGET/FINANCIAL SUMMARY

COMPREHENSIVE PLAN GOAL

COUNCIL ACTION

Motion: _____
Second: _____
Vote: Ayes: _____ **Nays:** _____
Abstentions: _____

THE STATE OF TEXAS §
 §
COUNTY OF CAMERON §

LEASE AGREEMENT
ELECTION EQUIPMENT

This Lease made and entered into this 6th day of October, 2010, by and between Cameron County, hereinafter called "Lessor", and the City of South Padre Island, hereinafter called "Lessee".

In consideration of the mutual covenants and agreements herein set forth, and other good and valuable consideration, Lessor does lease to Lessee one (1) AutoMark(s) (Voter Assist Terminals), version 1.1.2258 @ \$540.00, hereinafter called "Equipment".

I.
Terms

The term of this Lease shall be for the period of early voting and Election Day related to the November 2010, Special Election. This Lease expires on the third day after the canvassing of the subject election. Upon the expiration of this Lease, Lessee agrees to return the equipment by delivering the equipment to the Lessor in the same condition as it was delivered to lessee at the beginning of this Lease.

Delivery of the equipment past 7 days of the canvass date will incur a penalty of 10% of the total lease amount under **Section II, Consideration**. If the County Elections Office is to pick up the equipment from the lessee at their polling locations, the county may charge \$15.00/hr with a minimum of 2 hours and mileage at .44/mi. This fee must be paid before a new agreement or lease is considered.

II.
Consideration

In consideration for the use of the equipment, Lessee agrees to pay the sum of five hundred forty dollars (\$540.00). This Equipment Lease excludes any additional services such as programming, ballot layout, ballot production, etc. These services are available through Election Systems & Software, authorized vendor, and is the responsibility of the Lessee.

III.
Maintenance

Lessee agrees and covenants to keep and maintain in good repair all equipment during the term of this lease. In the event that any repairs are necessary due to negligence by lessee, lessee agrees to utilize the Election Systems & Software Company to provide the repair service and to pay for any repairs.

5-11

IV.
Improvements and Major Repairs

Lessee may not make any alternations, additions or improvements to the equipment.

V.
No Partnership

This Lease shall not give rise to a partnership relation between the parties hereto. Neither party shall have the authority to bind the other without its written consent.

VI.
Indemnification

Lessee agrees and covenants to indemnify and hold Lessor harmless against any and all claims, demands, damages, costs, and expenses, including reasonable attorney fees for the defense, thereof, arising from the conduct or management of Lessee's business or its use of the equipment. In the event that any action or proceeding is brought against Lessor by reason of any of the above, Lessee further agrees and covenants to defend the action or proceeding by legal counsel acceptable to Lessor.

VII.
No Assignment or Sublease

Lessee may not assign this Lease without the prior written consent of Lessor.

VIII.
Notices

All notices to Lessor shall be sent by certified or registered mail, addressed to: Cameron County Elections Division, Cameron County Courthouse 954 E. Harrison Street, P. O. Box 3587, Brownsville, Texas 78522, or at such other address as the County may otherwise designate. All notices to Lessee shall be sent certified or registered mail, addressed to: Town of South Padre Island, 4601 Padre Boulevard, South Padre Island, Texas, 78597, or at such other address as Lessee may otherwise designate in writing.

IX.
Breach

If Lessor or Lessee fails to carry out any provision of this Lease, the other party shall have the right to terminate this Lease with three (3) days written notice, hand delivered to the other party.

X.
Entire Agreement – Amendment

This Lease shall constitute the entire understanding of the parties hereto with respect to the subject matter hereof, and no amendment, modification, or alternation of the terms hereof shall be binding unless the same be in writing, dated subsequent to the date hereof, and duly executed by the parties hereto.

XII.
Law Governing; Venue

This Lease shall be governed by and construed in accordance with the laws of the State of Texas, and the obligations and undertaking of each of the parties to this lease shall be performable in Cameron County, Texas.

IN WITNESS WHEREOF, the undersigned Lessor and Lessee hereto executed this Lease as of the day and year above written.

LESSOR

LESSEE

Cameron County

City of South Padre Island
(City/School Dist/other Pol. Subd)

By: Rogelio Ortiz, Elections Administrator

By:

Date

Date

5-13

**SOUTH PADRE ISLAND
CITY COUNCIL MEETING
AGENDA REQUEST FORM**

MEETING DATE: October 6, 2010

NAME/DEPT.: Reuben Trevino, Coastal Resources Manager

ITEM

Discussion and action to approve Resolution No. 2010-26 of the City of South Padre Island, Texas (the "Applicant"), authorizing the submission of four grant applications to the Texas General Land Office ("GLO") Texas Coastal Management Plan ("CMP") and authorizing a designated official to execute all documents and application forms on behalf of the City of South Padre Island.

ITEM BACKGROUND

The Coastal Management Program Grant Cycle 16 is now available. All applications must be completed by October 13, 2010. This program allows for beach shoreline access, rehabilitation of vegetation, and other areas of coastal management. The City applied for four applications last cycle. Two of the available projects were previously submitted and the City staff has scores and edits to improve future applications.

Per the City Council meeting on 6/2/10, City staff was directed to fill out three applications. The applications in priority order are:

1. Sapphire Circle
2. Dune Restoration
3. Marina Project

RECOMMENDATIONS/COMMENTS

The Beach and Dune Task Force priorities include: Parking lot and new walkover at Sapphire Circle (#23).

Dune restoration is volunteer project requesting the grantor to purchase the plants.

BUDGET/FINANCIAL SUMMARY

Each grant application requires a **40% match** to be utilized with cash or in-kind match. Cost breakdown for each grant is included in the back-up documents. The total amount of cash match must be budgeted for the next fiscal year. Dune restoration is the only grant project utilizing all in-kind match.

Total anticipated match and grant costs:

Sapphire Circle:

Grant application costs: \$122,393.75
Match Requirements: \$ 81,595.84

Dune Restoration:

Grant application costs: \$48,000.00
Match Requirements: \$32,050.00 (ALL INKIND)

Marina:

Grant application costs: \$208,000.00
Match Requirements: \$192,000.00

COMPREHENSIVE PLAN GOAL

Chapter 4 – Parking Plan

Chapter 5 – Issue 1 – Protection and enhancement of the beach and dunes

5.1 Construct or reconstruct walkovers at all designated beach access points wide enough to allow pedestrians traveling in opposite directions. Simultaneously, construct directional barriers to prevent breached access to the dunes.

5.6 Establish or strengthen an ongoing, regular dune maintenance program. Continue to leverage access to State and Federal funds to continuously sustain this activity.

COUNCIL ACTION

Motion: _____

Second: _____

Vote: Ayes: _____ Nays: _____

Abstentions: _____



RESOLUTION NO. 2010-26

RESOLUTION AUTHORIZING APPLICATION

TEXAS GENERAL LAND OFFICE – CMP PROGRAM

A RESOLUTION OF THE CITY OF SOUTH PADRE ISLAND, TEXAS (the “Applicant”), AUTHORIZING THE SUBMISSION OF THREE GRANT APPLICATIONS TO THE TEXAS GENERAL LAND OFFICE (“GLO”) TEXAS COASTAL MANAGEMENT PLAN (“CMP”) AND AUTHORIZING A DESIGNATED OFFICIAL TO EXECUTE ALL DOCUMENTS AND APPLICATION FORMS ON BEHALF OF THE CITY OF SOUTH PADRE ISLAND.

WHEREAS, the Applicant is fully eligible to receive assistance under GLO; and

WHEREAS, the Applicant wishes to authorize an official to represent the Applicant in dealing with GLO concerning all program aspects;

NOW, THEREFORE, BE IT RESOLVED BY THE CITY COUNCIL OF THE CITY COUNCIL OF SOUTH PADRE ISLAND, TEXAS:

SECTION 1: the Applicant hereby certifies that it is eligible to receive assistance under the Program for the following essential programs:

1. Sapphire Circle
2. Dune Restoration
3. Marina Project

SECTION 2: the Applicant hereby authorizes and directs its City Manager to act for the applicant in dealing with GLO for the purpose of the Program, and the City Manager is officially designated as the representative of the Applicant in this regard.

SECTION 3: the Applicant hereby specifically authorizes the above-named official to do all acts necessary to apply for and receive assistance from GLO related to the Projects. Joni Clarke is authorized to execute on behalf of the Applicant any agreements, licenses or other documents required by GLO for Applicant’s participation in the Program.

PASSED, APPROVED AND ADOPTED on this the 6th day of OCTOBER, 2010.

ATTEST:

CITY OF SOUTH PADRE ISLAND, TEXAS

Susan M. Hill, City Secretary

Robert N. Pinkerton, Jr., Mayor

**CITY OF SOUTH PADRE ISLAND
CITY COUNCIL MEETING
AGENDA REQUEST FORM**

MEETING DATE: October 6, 2010

NAME/DEPT.: Rick Vasquez, Transit & Development Director
Jesse Arriaga, General Manager of Public Transportation

ITEM

Discussion and Action to accept FTA grant in the amount of \$26,593, Federal Contract ED 1006, for the installation of security cameras on WAVE buses. This action will increase the security camera project budget and FTA grant amount by \$26,593.

ITEM BACKGROUND

The City Council previously accepted Federal contract ED 51021F7292 in the amount of \$16,353, for the installation of security cameras on the WAVE buses for a total grant amount of \$42,946.00 for this project.

RECOMMENDATIONS/COMMENTS

5310 (f) Transit Program

This program (49 U.S.C. 5310) provides formula funding to States for the purpose of assisting private nonprofit groups in meeting the transportation needs of the elderly and persons with disabilities when the transportation service provided is unavailable, insufficient, or inappropriate to meeting these needs. Funds are apportioned based on each State's share of population for these groups of people.

Eligible Activities

Capital expenses that support transportation to meet the special needs of older adults and persons with disabilities.

Federal funds will be utilized for the purchase of bus security cameras.

BUDGET/FINANCIAL SUMMARY

This project is completely funded by the FTA grant, this will not impact the General Fund.

COMPREHENSIVE PLAN GOAL

Chapter 4. Mobility Plan

Goal 4.I Increase ridership on the WAVE both residents & visitors.

COUNCIL ACTION

Motion: _____

Second: _____

Vote: Ayes: _____ Nays: _____

Abstentions: _____

**CITY OF SOUTH PADRE ISLAND
CITY COUNCIL MEETING
AGENDA REQUEST FORM**

MEETING DATE: October 6, 2010

NAME/DEPT.: Dan Quandt, CVB Executive Director

ITEM

Discussion and action concerning a resolution of the City Council of South Padre Island, Texas supporting the Bikefest Bubba Blackwell Motorcycle Jump October 8, 2010 and supporting temporary closure of part of Padre Boulevard (Highway 100) for the event.

ITEM BACKGROUND

This motorcycle jump, which has been part of Bikefest previously, requires temporarily closing Padre Boulevard between Huisache and Mesquite Streets between 3:00-5:30 pm Friday, October 8th. This also requires TxDOT approval. Their process requires this resolution.

RECOMMENDATIONS/COMMENTS

Recommend approval

BUDGET/FINANCIAL SUMMARY

None.

COMPREHENSIVE PLAN GOAL

COUNCIL ACTION

Motion: _____

Second: _____

Vote: Ayes: _____ **Nays:** _____

Abstentions: _____



RESOLUTION NO. 2010-27

RESOLUTION OF THE CITY COUNCIL OF THE CITY OF SOUTH PADRE ISLAND, TEXAS, SUPPORTING THE BIKEFEST BUBBA BLACKWELL MOTORCYCLE JUMP OCTOBER 8, 2010 OCTOBER AND SUPPORTING TEMPORARY CLOSURE OF PART OF PADRE BOULEVARD (HIGHWAY 100) FOR THE EVENT.

WHEREAS, the Bubba Blackwell Motorcycle Jump is returning as an event for Bikefest 2010 and;

WHEREAS, the implementation of this motorcycle jump requires our consent by resolution for temporary closure of a state right of way from 3:00 pm - 5:30 pm Friday, October 8, 2010 between Huisache and Mesquite Streets;

NOW THEREFORE, BE IT RESOLVED BY THE CITY COUCIL OF THE CITY OF SOUTH PADRE ISLAND, TEXAS, THAT:

The City Council hereby adopts Resolution No. 2010-27, supporting the Bubba Blackwell Motorcycle Jump as part of SPI Bikefest 2010, October 8, 2010. This resolution includes our support for a temporary closure of state right of way. The City will also provide the appropriate city services to assure the success of the event.

We authorize the City Manager to enter into agreement with the Texas Department of Transportation concerning this October 8, 2010 event, under the conditions specified in the agreement.

PASSED, ADOPTED AND APPROVED ON THIS THE 6th DAY OF OCTOBER, 2010.

Robert N. Pinkerton, Jr., Mayor

ATTEST:

Susan Hill, City Secretary

**CITY OF SOUTH PADRE ISLAND
CITY COUNCIL WORKSHOP
AGENDA REQUEST FORM**

MEETING DATE: October 6, 2010

NAME/DEPT.: James Mitchim, Building Official

ITEM

Approval of Second Reading of Ordinance No. 10-29 amending Chapter 4, Article 1, Section 4-5((A) by providing for the adoption of the 2009 International Residential Code without Section P2904 and modification of the exception in Section R302.2.

ITEM BACKGROUND

RECOMMENDATIONS/COMMENTS

BUDGET/FINANCIAL SUMMARY

COMPREHENSIVE PLAN GOAL

COUNCIL ACTION

Motion: _____

Second: _____

Vote: Ayes: _____ Nays: _____

Abstentions: _____

5-22

ORDINANCE NO. 10-29

AN ORDINANCE OF THE CITY OF SOUTH PADRE ISLAND AMENDING THE CODE OF ORDINANCES OF SUCH CITY BY AMENDING CHAPTER 4, ARTICLE I, SECTION 4-5(A) BY PROVIDING FOR THE ADOPTION OF THE 2009 INTERNATIONAL RESIDENTIAL CODE WITHOUT SECTION P2904 AND MODIFICATION OF THE EXCEPTION IN SECTION R302.2; PROVIDING FOR A PENALTY OF FIVE HUNDRED DOLLARS (\$500.00) FOR ANY VIOLATION; PROVIDING FOR SEVERABILITY; AND PROVIDING FOR PUBLICATION IN CAPTION FORM.

NOW, THEREFORE, BE IT ORDAINED BY THE CITY COUNCIL OF THE CITY OF SOUTH PADRE ISLAND, TEXAS:

Section 1. Section 4-5 (A) of Article I of Chapter 4 of the Code of Ordinances of the City of South Padre Island is hereby amended to provide for the adoption of the 2009 International Residential Code without Section P2904 and modification of the exception in Section R302.2 within the City and such Section 4-5 (A) shall hereafter read as follows:

Sec. 4-5 Adoption of the Standard Codes.

A) "The Town adopts the 2009 International Building Code, 2009 International Residential Code without Section P2904 (deleted) and the Exception in Section R302.2 does not apply unless the townhouses install a sprinkler system, 2009 International Fire Code, 2009 International Mechanical Code, 2009 International Plumbing Code, 2009 International Fuel Gas Code, 2008 National Electrical Code, 1997 Standard Housing Code, and the 1985 Unsafe Building Abatement Code and all other amendments thereto except as modified by the Code of Ordinances."

Section 2. Any violation of the above amended sections of Chapter 4 of the Code of Ordinances of the City of South Padre Island may be punished by a fine not to exceed Five Hundred Dollars (\$500.00) for each offense or for each day such offense shall continue and the penalty provisions of Section 21-1 of the Code of Ordinances is hereby adopted and incorporated for all purposes.

Section 3. If for any reason any section, paragraph, subdivision, clause, phrase, word or provision of this ordinance shall be held invalid or unconstitutional by final judgment of a court of competent jurisdiction, it shall not affect any other section, paragraph, subdivision, clause, phrase, word or provision of this ordinance for it is the definite intent of this City Council that every section, paragraph, subdivision, clause, phrase, word or provision hereof be given full force and effect for its purpose.

Section 4. This Ordinance shall become effective when published in caption form.

PASSED, APPROVED AND ADOPTED on First Reading, the 15th day of September 2010.
PASSED, APPROVED AND ADOPTED on Second Reading, the ___ day of _____, 2010.

ATTEST:

CITY OF SOUTH PADRE ISLAND, TEXAS

SUSAN HILL, CITY SECRETARY

ROBERT N. PINKERTON, JR., MAYOR

**CITY OF SOUTH PADRE ISLAND
CITY COUNCIL WORKSHOP
AGENDA REQUEST FORM**

MEETING DATE: October 6, 2010

NAME/DEPT.: Joni Clarke, City Manager

ITEM

Approval of Second Reading of Ordinance No. 10-30 amending Chapter 4, Article V and Chapter 20, Section 20-8.3(C) of the Code of Ordinances, repealing Resolution No. 2009-30 and creating the Development Standards Review Task Force.

ITEM BACKGROUND

RECOMMENDATIONS/COMMENTS

BUDGET/FINANCIAL SUMMARY

COMPREHENSIVE PLAN GOAL

COUNCIL ACTION

Motion: _____

Second: _____

Vote: Ayes: _____ **Nays:** _____

Abstentions: _____



ORDINANCE NO. 10-30

AN ORDINANCE OF THE CITY COUNCIL OF THE CITY OF SOUTH PADRE ISLAND, TEXAS, AMENDING CHAPTER 4, ARTICLE V OF THE CODE OF ORDINANCES, CHAPTER 20, SECTION 20-8.3(C) OF THE CODE OF ORDINANCES, REPEALING RESOLUTION 2009-30 AND CREATING THE DEVELOPMENT STANDARDS REVIEW TASK FORCE

WHEREAS, the Development Plan Review Board was created by Chapter 4, Article V of the Code of Ordinances; and

WHEREAS, the Form-Based Code Commission was created by Chapter 20, Section 20-8.3(c) of the Code of Ordinances; and

WHEREAS, the Padre Boulevard Revitalization Implementation Committee was established by Resolution 2009-30; and

WHEREAS, each of these committees have similar goals and responsibilities; and

WHEREAS, combining these three committees will be a more effective and efficient use of resources.

NOW, THEREFORE, BE IT ORDAINED BY THE CITY COUNCIL OF THE CITY OF SOUTH PADRE ISLAND, TEXAS:

Section 1: The City Council supports and approves the creation of the Development Standards Review Task Force.

Section 2: The Development Standards Review Task Force shall conduct all its meetings at in a public setting preferably at City Hall and shall follow all of the procedures required by the Open Meetings Act.

Section 3: The City Council may appoint seven (9) members to serve on the Development Standards Review Task Force which members may consist of the existing members of the Development Plan Review Board, the Form-Based Code Commission, the Padre Boulevard Revitalization Implementation Committee. The Committee members will have two year staggered terms with the Chairman and Vice-Chairman

5-25

elected annually by the Committee. Staggered terms will expire on the 30th of September each year. For the initial terms the appointed committee members will draw for term lengths, four (4) of the terms will be for one (1) year and five (5) of the terms will be for two (2) years.

Section 4: The Development Standards Review Task Force will establish goals annually including the following general objectives:

- Make recommendations regarding design guidelines and ordinances for all development, public and private
- Administer the City's Form-Based Code, as adopted by the City Council
- Develop guidelines for the enhancement of Padre Boulevard
- Consider variances to established development regulations, when appropriate

PASSED, APPROVED AND ADOPTED on First Reading, this the 15th day of September, 2010.

PASSED, APPROVED AND ADOPTED on Second Reading, this the ____ day of _____, 2010.

ATTEST:

CITY OF SOUTH PADRE ISLAND, TEXAS

Susan M. Hill, City Secretary

Robert N. Pinkerton, Jr., Mayor

**CITY OF SOUTH PADRE ISLAND
CITY COUNCIL MEETING
AGENDA REQUEST FORM**

MEETING DATE: October 6, 2010

NAME/DEPT.: Darla A. Jones, Assistant City Manager

ITEM

Approval of Resolution No. 2010-28 requesting the Texas Legislature increase funding for the Texas Recreation and Parks Account Local Park Grant Program

ITEM BACKGROUND

Port Isabel Mayor Joe Vega (and Deputy Director of Cameron County Parks System) sent this request. TRAPS, a statewide volunteer organization promoting Parks and Recreation activities, is asking cities and counties to pass this resolution. The state earmarks the sales tax collected at Sporting Goods stores to fund Texas Parks and Wildlife Department and their grant programs. With the projected state budget deficit, TRAPS is seeking support from local communities requesting the legislature leave the sporting goods sales tax intact and explore ways to increase funding.

RECOMMENDATIONS/COMMENTS

Pass resolution.

BUDGET/FINANCIAL SUMMARY

No effect on budget (potential future grants).

COMPREHENSIVE PLAN GOAL

N/A

COUNCIL ACTION

Motion: _____

Second: _____

Vote: Ayes: _____ **Nays:** _____

Abstentions: _____

5-27



RESOLUTION NO. 2010-28

**A RESOLUTION OF THE CITY OF SOUTH PADRE ISLAND
CITY COUNCIL REQUESTING THE MEMBERS OF THE 82nd
LEGISLATIVE SESSION OF THE STATE OF TEXAS SUPPORT
LEGISLATION THAT INCREASES FUNDING FOR THE TEXAS
RECREATION & PARKS ACCOUNT LOCAL PARK GRANT
PROGRAM AND THE TEXAS STATE PARK SYSTEM**

WHEREAS, the Texas Parks & Wildlife Department (“TPWD”) administers the Texas Recreation & Parks Account Local Park Grant Program (“TRPA”) and manages 93 State parks and historical sites in Texas; and

WHEREAS, TPWD has a separate account in their general revenue fund referred to as the TRPA for the purpose of providing matching grants to political subdivisions for parks and recreation projects; and

WHEREAS, the matching grants provided by the TPWD are utilized for the planning, acquisition, and development of local park, recreation and open space areas to be owned and maintained by political subdivisions; and

WHEREAS, funds granted to political subdivisions under the TRPA guidelines have funded 1,495 projects of the 2,913 submitted over 29 years delivering over \$792 million dollars to the local Texas economy; and

WHEREAS, political subdivisions throughout the State of Texas depend on grants from TPWD through the TRPA to stimulate the acquisition and development of parks and recreational areas for the benefit and enjoyment of their citizenry; and

WHEREAS, the TRPA and State parks are funded from sales tax on sporting goods and that the development of new parks stimulates the purchase of sporting goods; and

WHEREAS, the maintenance and improvements of State park and historic sites and the addition of new parks is a priority to Texans due to the State’s expanding population and extensive tourism industry; and

WHEREAS, the development of parks encourages and promotes public health, economic development, job creation, education; corporate relocations, an improved quality of life, and juvenile crime prevention; and

WHEREAS, funds are needed for major repairs at state parks and for the acquisition and development of parks and facilities; and

WHEREAS, it is the desire of this City Council that a copy of this resolution with appropriate names affixed be presented to the Governor of Texas and the leadership of the 82nd Texas Legislature.

NOW, THEREFORE, BE IT RESOLVED BY THE CITY COUNCIL OF THE CITY OF SOUTH PADRE ISLAND, TEXAS:

1. That members of the 82nd Legislature of Texas seek passage of legislation maximizing the use of revenue from the sporting goods sales tax to increase funding for parks and recreation programs for both Local and State parks and that all TRPA funded park projects be subject to the established TPWD competitive scoring system.

PASSED AND APPROVED by the South Padre Island City Council on this the 6th day of October 2010.

APPROVED:

Robert N. Pinkerton, Mayor

ATTEST:

Susan Hill, City Secretary

**CITY OF SOUTH PADRE ISLAND
CITY COUNCIL WORKSHOP
AGENDA REQUEST FORM**

MEETING DATE: October 6, 2010

NAME/DEPT.: City Council

ITEM

Discussion and action to appoint members to expiring and/or new terms of the Town's committees, boards and commissions.

ITEM BACKGROUND

The following committees have terms that are up for appointment:

- a. Bay Area Task Force Implementation Committee: three (3) appointments needed.
- b. Beach and Dune Task Force: four (4) appointments needed.
- c. Convention and Visitors Authority Board: six (6) appointments needed.
 - *Full Service Hotel Industry* – two (2) appointments needed
 - *Limited Service Hotel Industry* – one (1) appointment needed.
 - *Condominium Industry* – one (1) appointment needed.
 - *Tourism Related Industry* (new) – one (1) appointment needed (must be a resident of South Padre Island).
 - *Citizen at Large* – one (1) appointment needed (must be a resident of South Padre Island).
- d. Development Standards Review Task Force (new): nine (9) appointments needed.
- e. Economic Development Corporation: three (3) appointments needed.
- f. Keep SPI Beautiful Committee: three (3) appointments needed.
- g. Parks, Recreation & Beautification Committee (new): seven (7) appointments needed.
- h. Planning and Zoning Commission: four (4) appointments needed.

RECOMMENDATIONS/COMMENTS

BUDGET/FINANCIAL SUMMARY

COMPREHENSIVE PLAN GOAL

COUNCIL ACTION

Motion: _____

Second: _____

Vote: Ayes: _____ **Nays:** _____

Abstentions: _____

EXPIRING TERMS FOR CITY OF SOUTH PADRE ISLAND'S
COMMITTEES, COMMISSIONS AND BOARDS

Bay Area Task Force Implementation Committee (3):

Troy Giles – application received – would like to serve again
Lynn Hughes – application received – would like to serve again
Steve O’Neal – does not want to serve at this time

No new applications have been received.

Beach and Dune Task Force (4):

Charlie Brommer - has not responded yet
Baylor Haynes – application received – would like to serve again
Rob Nixon – application received – would like to serve again
Leah Thrash – does not want to serve at this time

New Applications:

Troy Giles

Convention and Visitors Authority Board (6):

Steve Meadows (*Full Service Hotel Industry*) – has not responded yet
Bill Donahue (*Full Service Hotel Industry*) – does not want to serve at this time
Mike Klement (*Limited Service Hotel Industry*) – has not responded yet
Stormy Wall (*Condominium Industry*) – has not responded yet
Ann Smith (*Citizen at large*) – does not want to serve at this time
New seat (*Tourism Related Industry*)

New Applications:

Jacky Conrad
Joe Ricco
Daniel Salazar
Lynne Tate
Sean Till
Peggy Trahan

Development Standards Review Task Force (9): This is a newly created Task Force (Ordinance No. 10-30)

New Applications:

Joe Baker (FBCC/PBRIC)
Beth Fedigan (FBCC/PBRIC)
Bob Fudge (BFCC/PBRIC)
James Helms
Jody Hughes (DPRB)
George Lesieutre (DPRB)
Joe Logan (FBCC) (is supposed to submit application on Monday – has been out of town)
Nancy Moyer (DPRB/PBRIC)
Steve O’Neil (FBCC)

Economic Development Corporation Board of Directors (3):

Richard Franke – would like to serve again
Peggy Trahan – has not responded yet
Joanne Williams – has not responded yet

New Applications:

George Lesieutre

Historic Preservation Committee (3): Note: these applications will be sent to the CVA for their recommendation to the City Council – No action from the Council at this time.

Keep SPI Beautiful Committee (3):

Ann Arendarczyk – does not want to serve at this time
Laurie Gaudi – does not want to serve at this time
Roxanne Guenzel (resigned)

No new applications have been received.

Parks, Recreation & Beautification Committee (7): This is a newly created committee (Resolution No. 2010-25)

New Applications:

Jacky Conrad
Jody Hughes

Planning and Zoning Commission (4):

Robert Fudge – would like to serve again
Russell Judah – would like to serve again
Patrick McNulty – would like to serve again
Gary Olle – would like to serve again

New Applications:

James Helms

Bay Area Task Force Implementation Committee

3 Positions expiring

Incumbents requesting another term:

- Troy Giles
- Lynn Huges

New Applications: None

BATF

**CANDIDATE APPLICATION FORM
FOR COUNCIL-APPOINTED BOARDS, COMMITTEES &
COMMISSIONS**

Information disclosed on this application or any other attached document may be disclosed in public meetings. Please print clearly.

Board Preference 1: Bay Area Task Force

Board Preference 2: Beach & Dunes

Name: Troy Giles

Home Address: 5813 Padre Blvd.

City: South Padre Island Zip: 78597 SPI Resident: 37 years

Home Telephone: 956-761-4060 Home Fax: 956-761-6080

Home E-Mail: Troy@troggilesrealty.com

Profession: Real Estate Broker

Business Name: Troy Giles Realty and Management

Business Address: 5813 Padre Blvd.

City: South Padre Island State: TX Zip: 78597

Business Telephone: 956-761-2040

Business E-Mail: Troy@troggilesrealty.com

Special Knowledge or Experience applicable to City Committee Function: 35+ years of

South Padre Beach and Bay Activities. Instrumental in the development of the first beach management plan and the first beach renourishment.

I was an original member and am a present member of the

Other Information (Civic Activities): Bay Area Task Force. Served 2, two year terms as a South Padre Island Alderman. I would like to see the B&D and BATF merge and to be a supportive member of the new Committee

I verify that the information I have provided in this application to be true and correct. I also acknowledge that this information may be made available to the public.

Signature

Date

10.1.2010

PLEASE RETURN COMPLETED APPLICATION TO THE CITY SECRETARY'S OFFICE, CITY OF SOUTH PADRE ISLAND, 4601 PADRE BLVD., SOUTH PADRE ISLAND, TX 78597; EMAIL SHILL@SOUTHPADRETEXAS.GOV OR FAX 956/761-3888

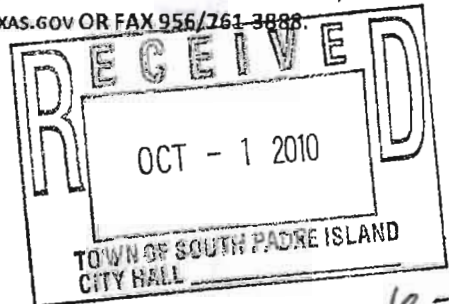

6-7



City of South Padre Island – Committees, Boards and Commissions

Questionnaire

4601 Padre Blvd.
South Padre Island, TX 78597

Phone: 956/761-6456

Fax: 956/761-3888

APPLICANT INFORMATION

Last Name: Giles First: Troy M.I.: W Date: 10/1/2010

Street Address: 5813 Padre Blvd. Apartment/Unit #:

City: South Padre Island State: TX Zip: 78597

Phone: 956-551-2040 E-mail Address: Troy@TroyGilesRealty.com

Occupation (Place of Business): Real Estate Broker Phone: 956-761-2040

Are you a citizen of the United States? Yes [checked] No []

Have you ever been convicted of a felony? Yes [] No [checked] If yes, please explain

Have you ever been convicted of, received probation or deferred adjudication for any offense that was not a felony? Yes [] No [checked] If yes, please explain

Do you have a current Driver's License? Yes [checked] No []

Have you been a resident of the City of South Padre Island for at least six (6) months prior to the date of application? Yes [checked] No []

If qualified, are you a registered South Padre Island voter? Yes [checked] No []

Are you an adversary party to pending litigation against the City of South Padre Island? Have you ever been an adversary part to litigation against the City of South Padre Island? Yes [] No [checked] If yes, please explain

Are you an employee or a business associate of either an adversary party or a representative of an adversary party in any past or pending litigation against the City of South Padre Island, other than an eminent domain proceeding? Yes [] No [checked] If yes, please explain

Are you an employee or a business associate of either an adversary party or a representative of an adversary party that has a pecuniary interest in any past or pending litigation or claim against the City of South Padre Island, other than an eminent domain proceeding? Yes [] No [checked] If yes, please explain

Are you in arrears on any City of South Padre Island taxes, water service charge or other obligations owned to the City of South Padre Island? Yes [] No [checked] If yes, please explain

Provide All Information Requested: INCOMPLETE APPLICATIONS WILL NOT BE CONSIDERED FOR COMMITTEE, BOARD OR COMMISSION OPPORTUNITIES. Your complete application form will be maintained in our active files for six (6) months from the date of the application. I understand that should I not be appointed to the City of South Padre Island committee, board or commission, this application and any other records obtained, collected or otherwise prepared regarding this application shall be maintained in accordance with the Texas Public Information Act and the City of South Padre Island's document retention schedule.

6-8

DISCLAIMER AND SIGNATURE

I certify that my answers are true and complete. I understand that the information contained in this application may be considered, among other criteria, qualifications and/or information, by the City Council in its evaluation for the position being sought. I further understand that should I be appointed to any City of South Padre Island committee, board, or commission, I serve at the pleasure of the South Padre Island City Council and may be removed from said position at any time and for any reason or no reason at all, with or without notice. I also understand that should I be appointed to a City of South Padre Island Board or Commission, I must be responsible for a creditable record of attendance and performance. If this application leads to my appointment to a position on a City of South Padre Island Committee, Board or Commission, I understand that false or misleading information in my application may result in my removal from the position.

Signature

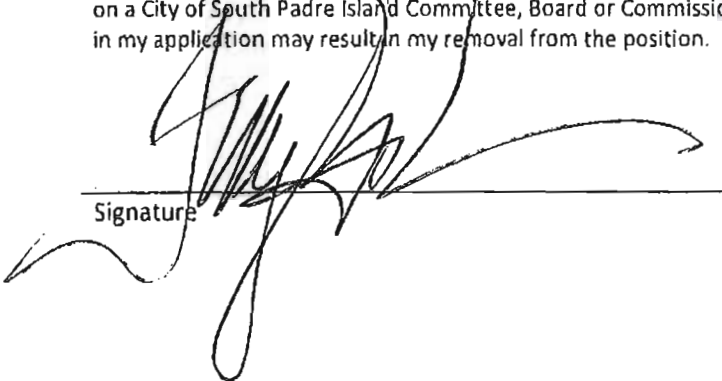
A large, stylized handwritten signature in black ink, written over a horizontal line. The signature is highly cursive and difficult to decipher.

Date

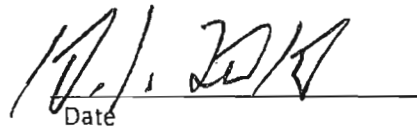
A handwritten date in black ink, written over a horizontal line. The date appears to be "10/1/2015".

**CANDIDATE APPLICATION FORM
FOR COUNCIL-APPOINTED BOARDS, COMMITTEES &
COMMISSIONS**

Information disclosed on this application or any other attached document may be disclosed in public meetings. Please print clearly.

Board Preference 1: BAY AREA TASK FORCE

Board Preference 2: _____

Name: LYNN HUGHES

Home Address: 225 W. CAROLYN POB 3666

City: SPI TX Zip: 78597 SPI Resident: 10 years

Home Telephone: 956-761-2544 Home Fax: 214-395-8191 cell

Home E-Mail: LYNNHUGHES39@YAHOO.COM

Profession: RETIRED

Business Name: _____

Business Address: _____

City: _____ State: _____ Zip: _____

Business Telephone: _____

Business E-Mail: _____

Special Knowledge or Experience applicable to the Committee Function:

Member of BATE since inception. Currently working on new projects.

Other Information (Civic Activities): _____

I verify that the information I have provided in this application to be true and correct. I also acknowledge that this information may be made available to the public.

Lynn Hughes
Signature

9/30/10
Date

PLEASE RETURN COMPLETED APPLICATION TO THE CITY SECRETARY'S OFFICE, CITY OF SOUTH PADRE ISLAND, 4601 PADRE BLVD., SOUTH PADRE ISLAND, TX 78597; EMAIL SKILL@SOUTHPADRETEXAS.GOV OR FAX 956/761-3888.

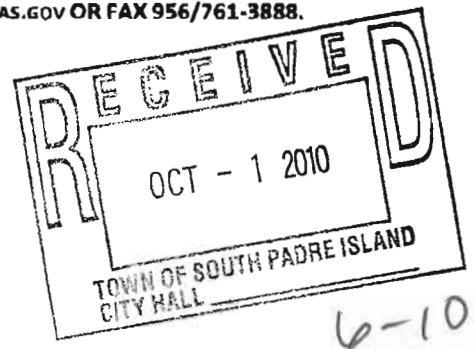



City of South Padre Island - Committees, Boards and Commissions
Questionnaire

4601 Padre Blvd.
South Padre Island, TX 78597

Phone: 956/761-6456
Fax: 956/761-3888

APPLICANT INFORMATION

Last Name: HUGHES First: LYNN M.I.: _____ Date: 9/30/10
 Street Address: 225 W CAROLYN Apartment/Unit #: _____
 City: SPI State: TX Zip: 78597
 Phone: 956-761-2504 E-mail Address: LYNNHUGHES39@YAHOO.C
 Occupation (Place of Business): _____ Phone: _____

Are you a citizen of the United States? Yes No

Have you ever been convicted of a felony? Yes No If yes, please explain: _____

Have you ever been convicted of, received probation or deferred adjudication for any offense that was not a felony? Yes If yes, please explain: _____
 No

Do you have a current Driver's License? Yes No

Have you been a resident of the City of South Padre Island for at least six (6) months prior to the date of application? Yes No

If qualified, are you a registered South Padre Island voter? Yes No

Are you an adversary party to pending litigation against the City of South Padre Island? Have you ever been an adversary part to litigation against the City of South Padre Island? Yes If yes, please explain: _____
 No

Are you an employee or a business associate of either an adversary party or a representative of an adversary party in any past or pending litigation against the City of South Padre Island, other than an eminent domain proceeding? Yes If yes, please explain: _____
 No

Are you an employee or a business associate of either an adversary party or a representative of an adversary party that has a pecuniary interest in any past or pending litigation or claim against the City of South Padre Island, other than an eminent domain proceeding? Yes If yes, please explain: _____
 No

Are you in arrears on any City of South Padre Island taxes, water service charge or other obligations owned to the City of South Padre Island? Yes If yes, please explain: _____
 No

Provide All Information Requested: INCOMPLETE APPLICATIONS WILL NOT BE CONSIDERED FOR COMMITTEE, BOARD OR COMMISSION OPPORTUNITIES. Your complete application form will be maintained in our active files for six (6) months from the date of the application. I understand that should I not be appointed to the City of South Padre Island committee, board or commission, this application and any other records obtained, collected or otherwise prepared regarding this application shall be maintained in accordance with the Texas Public Information Act and the City of South Padre Island's document retention schedule.

6-11



I certify that my answers are true and complete. I understand that the information contained in this application may be considered, among other criteria, qualifications and/or information, by the City Council in its evaluation for the position being sought. I further understand that should I be appointed to any City of South Padre Island committee, board, or commission, I serve at the pleasure of the South Padre Island City Council and may be removed from said position at any time and for any reason or no reason at all, with or without notice. I also understand that should I be appointed to a City of South Padre Island Board or Commission, I must be responsible for a creditable record of attendance and performance. If this application leads to my appointment to a position on a City of South Padre Island Committee, Board or Commission, I understand that false or misleading information in my application may result in my removal from the position.

Laura Hughes
Signature

9/30/10
Date

6-12

Beach and Dune Task Force

4 Positions expiring

Incumbents requesting another term:

- Baylor Haynes
- Rob Nixon

New Applications:

- Troy Giles

**CANDIDATE APPLICATION FORM
FOR COUNCIL-APPOINTED BOARDS, COMMITTEES &
COMMISSIONS**

Information disclosed on this application or any other attached document may be disclosed in public meetings. Please print clearly.

Board Preference 1: Beach & Dunes

Board Preference 2: Bay area Task Force

Name: Troy Giles

Home Address: 5813 Padre Blvd.

City: South Padre Island Zip: 78597 SPI Resident: 37 years

Home Telephone: 956-761-4060 Home Fax: 956-761-6080

Home E-Mail: Troy@TroyGilesRealty.com

Profession: Real Estate Broker

Business Name: Troy Giles Realty and Management

Business Address: 5813 Padre Blvd.

City: South Padre Island State: TX Zip: 78597

Business Telephone: 956-761-2040

Business E-Mail: Troy@TroyGilesRealty.com

Special Knowledge or Experience applicable to City Committee Function:

35+ years of South Padre Beach and Bay activities. Instrumental in the development of the first beach management plan and the first beach renourishment. I was an original member and am a present member of the Bay Area Task Force

Served 2 two year terms as a South Padre Island Alderman. I would like to see the B&D and B&TF merge and to be a supportive member of the new committee.

I verify that the information I have provided in this application to be true and correct. I also acknowledge that this information may be made available to the public.

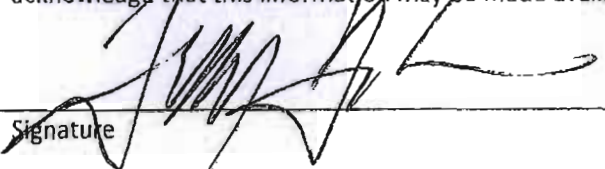
Signature 

Date 10.1.2010

PLEASE RETURN COMPLETED APPLICATION TO THE CITY SECRETARY'S OFFICE, CITY OF SOUTH PADRE ISLAND, 4601 PADRE BLVD., SOUTH PADRE ISLAND, TX 78597; EMAIL SHILL@SOUTHPADRETEXAS.GOV OR FAX 956/761-3888.

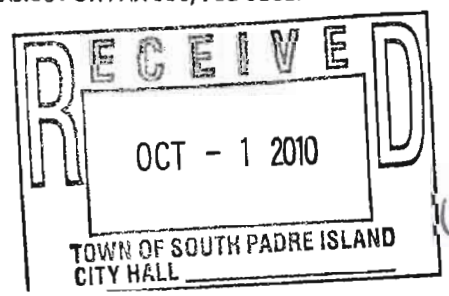

6-14



City of South Padre Island – Committees, Boards and Commissions
Questionnaire

4601 Padre Blvd.
South Padre Island, TX 78597

Phone: 956/761-6456
Fax: 956/761-3888

APPLICANT INFORMATION

Last Name: Giles First: Troy M.I.: W Date: 10/1/2010
Street Address: 5813 Padre Blvd. Apartment/Unit #: _____
City: South Padre Island State: TX Zip: 78597
Phone: 956-551-2040 E-mail Address: Troy@troygilesrealty.com
Occupation (Place of Business): Real Estate Broker Phone: 956-761-2040

Are you a citizen of the United States? Yes No

Have you ever been convicted of a felony? Yes No If yes, please explain _____

Have you ever been convicted of, received probation or deferred adjudication for any offense that was not a felony? Yes If yes, please explain: _____
No

Do you have a current Driver's License? Yes No

Have you been a resident of the City of South Padre Island for at least six (6) months prior to the date of application? Yes No

If qualified, are you a registered South Padre Island voter? Yes No

Are you an adversary party to pending litigation against the City of South Padre Island? Have you ever been an adversary part to litigation against the City of South Padre Island? Yes If yes, please explain: _____
No

Are you an employee or a business associate of either an adversary party or a representative of an adversary party in any past or pending litigation against the City of South Padre Island, other than an eminent domain proceeding? Yes If yes, please explain: _____
No

Are you an employee or a business associate of either an adversary party or a representative of an adversary party that has a pecuniary interest in any past or pending liltgation or claim against the City of South Padre Island, other than an eminent domain proceeding? Yes If yes, please explain: _____
No

Are you in arrears on any City of South Padre Island taxes, water service charge or other obligations owned to the City of South Padre Island? Yes If yes, please explain: _____
No

Provide All Information Requested: INCOMPLETE APPLICATIONS WILL NOT BE CONSIDERED FOR COMMITTEE, BOARD OR COMMISSION OPPORTUNITIES. Your complete application form will be maintained in our active files for six (6) months from the date of the application. I understand that should I not be appointed to the City of South Padre Island committee, board or commission, this application and any other records obtained, collected or otherwise prepared regarding this application shall be maintained in accordance with the Texas Public Information Act and the City of South Padre Island's document retention schedule.

6-15

DISCLAIMER AND SIGNATURE

I certify that my answers are true and complete. I understand that the information contained in this application may be considered, among other criteria, qualifications and/or information, by the City Council in its evaluation for the position being sought. I further understand that should I be appointed to any City of South Padre Island committee, board, or commission, I serve at the pleasure of the South Padre Island City Council and may be removed from said position at any time and for any reason or no reason at all, with or without notice. I also understand that should I be appointed to a City of South Padre Island Board or Commission, I must be responsible for a creditable record of attendance and performance. If this application leads to my appointment to a position on a City of South Padre Island Committee, Board or Commission, I understand that false or misleading information in my application may result in my removal from the position.

Signature

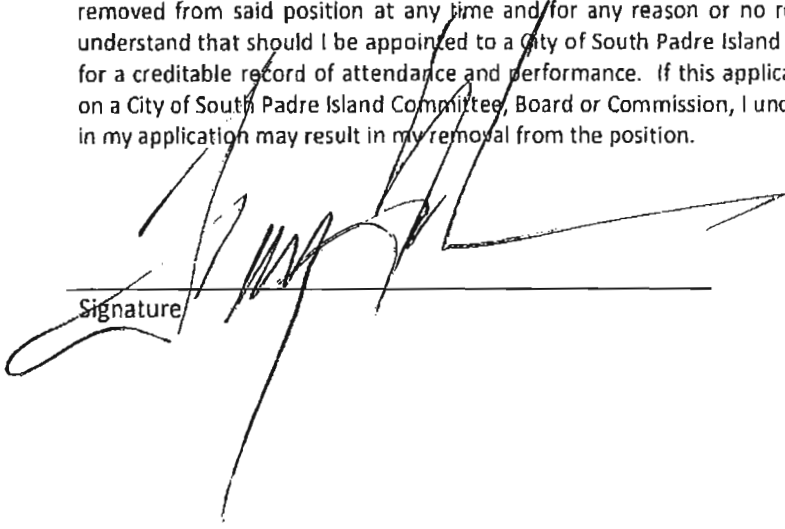
A large, stylized handwritten signature in black ink, written over a horizontal line. The signature is cursive and somewhat abstract, with long, sweeping strokes.

Date

10.1.2020

**CANDIDATE APPLICATION FORM
FOR COUNCIL-APPOINTED BOARDS, COMMITTEES &
COMMISSIONS**

Information disclosed on this application or any other attached document may be disclosed in public meetings. Please print clearly.

Board Preference 1: Berkel & Demo
Board Preference 2: _____

Name: Baylor R Haynes

Home Address: 5518 GULF PO BOX 2433

City: South Padre Island Zip: 78597 SPI Resident: 16 years

Home Telephone: 956 761 2286 Home Fax: _____

Home E-Mail: Baylor.Haynes@WEB-TV.NET

Profession: Retired USAF

Business Name: _____

Business Address: _____

City: _____ State: _____ Zip: _____

Business Telephone: _____

Business E-Mail: _____

Special Knowledge or Experience applicable to City Committee Function:

ON Board Now

Other Information (Civic Activities): _____

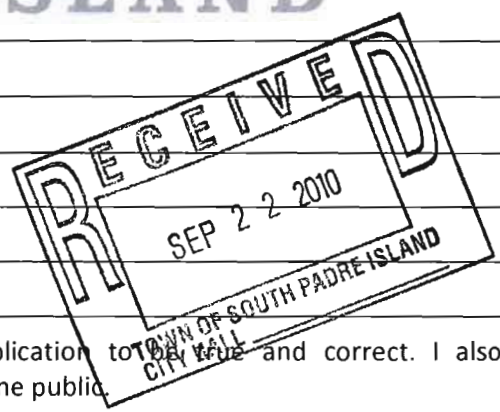

I verify that the information I have provided in this application to the City of South Padre Island is true and correct. I also acknowledge that this information may be made available to the public.

Baylor R Haynes
Signature

22 Sep 10
Date

PLEASE RETURN COMPLETED APPLICATION TO THE CITY SECRETARY'S OFFICE, CITY OF SOUTH PADRE ISLAND, 4601 PADRE BLVD., SOUTH PADRE ISLAND, TX 78597; EMAIL SHILL@SOUTHPADRETEXAS.GOV OR FAX 956/761-3888.

6-17



City of South Padre Island – Committees, Boards and Commissions
 Questionnaire
 4601 Padre Blvd.
 South Padre Island, TX 78597
 Phone: 956/761-6456
 Fax: 956/761-3888

APPLICANT INFORMATION

Last Name: HAYNES First: Baylor M.I.: R Date: Sept 22-10
 Street Address: 5518 GOIR BLVD Apartment/Unit #: _____
 City: South Padre Is State: TX Zip: 78597
 Phone: 956 761 2286 E-mail Address: BAYLORH@OWR.TX.NET
 Occupation (Place of Business): USAR Retiree Phone: _____

Are you a citizen of the United States? Yes No
 Have you ever been convicted of a felony? Yes No If yes, please explain _____
 Have you ever been convicted of, received probation or deferred adjudication for any offense that was not a felony? Yes No If yes, please explain: _____

Do you have a current Driver's License? Yes No
 Have you been a resident of the City of South Padre Island for at least six (6) months prior to the date of application? Yes No
 If qualified, are you a registered South Padre Island voter? Yes No

Are you an adversary party to pending litigation against the City of South Padre Island? Yes No If yes, please explain: _____

Are you an employee or a business associate of either an adversary party or a representative of an adversary party in any past or pending litigation against the City of South Padre Island, other than an eminent domain proceeding? Yes No If yes, please explain: _____

Are you an employee or a business associate of either an adversary party or a representative of an adversary party that has a pecuniary interest in any past or pending litigation or claim against the City of South Padre Island, other than an eminent domain proceeding? Yes No If yes, please explain: _____

Are you in arrears on any City of South Padre Island taxes, water service charge or other obligations owned to the City of South Padre Island? Yes No If yes, please explain: _____

Provide All Information Requested: INCOMPLETE APPLICATIONS WILL NOT BE CONSIDERED FOR COMMITTEE, BOARD OR COMMISSION OPPORTUNITIES. Your complete application form will be maintained in our active files for six (6) months from the date of the application. I understand that should I not be appointed to the City of South Padre Island committee, board or commission, this application and any other records obtained, collected or otherwise prepared regarding this application shall be maintained in accordance with the Texas Public Information Act and the City of South Padre Island's document retention schedule.

6-18

DISCLAIMER AND SIGNATURE

I certify that my answers are true and complete. I understand that the information contained in this application may be considered, among other criteria, qualifications and/or information, by the City Council in its evaluation for the position being sought. I further understand that should I be appointed to any City of South Padre Island committee, board, or commission, I serve at the pleasure of the South Padre Island City Council and may be removed from said position at any time and for any reason or no reason at all, with or without notice. I also understand that should I be appointed to a City of South Padre Island Board or Commission, I must be responsible for a creditable record of attendance and performance. If this application leads to my appointment to a position on a City of South Padre Island Committee, Board or Commission, I understand that false or misleading information in my application may result in my removal from the position.

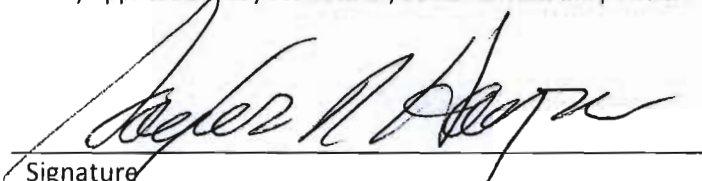

Signature

Date

6-19

**CANDIDATE APPLICATION FORM
FOR COUNCIL-APPOINTED BOARDS, COMMITTEES &
COMMISSIONS**

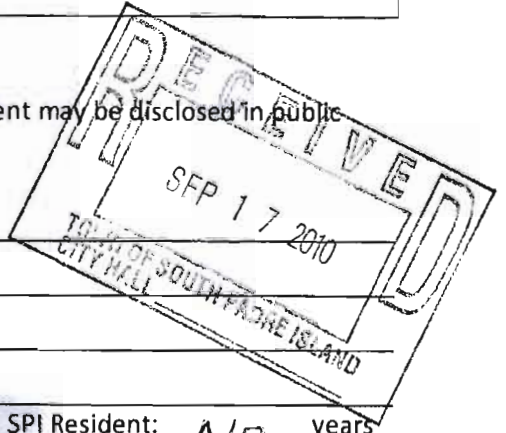
Information disclosed on this application or any other attached document may be disclosed in public meetings. Please print clearly.



Board Preference 1: Beach & Dune Task force

Board Preference 2: _____

Name: Robert Nixon

Home Address: 22 Augusta Drive

City: Laguna Vista Zip: 78578 SPI Resident: NO years

Home Telephone: 956-943-1778 Cell# 956-433-1472 Home Fax: _____

Home E-Mail: robaroo2000@gmail.com

Profession: Maintenance & Operations Manager

Business Name: Recoil, Inc. (Gravity Park)

Business Address: 106 West Marlin

City: South Padre Island State: TX Zip: 78597

Business Telephone: 956-761-8588

Business E-Mail: _____

Special Knowledge or Experience applicable to City or Board/Commission Function: well

versed in Open Beaches Act, organized & participated in multiple dune restoration projects and have already served a full term on the SPI Beach & Dune Task Force

Other Information (Civic Activities): Seafriender Foundation South Texas Chapter (Chairman), Keep SPI Beautiful Committee, Cameron County Andy Bowie Land Use Committee.

I verify that the information I have provided in this application to be true and correct. I also acknowledge that this information may be made available to the public.

[Signature]
Signature

9-17-10
Date

PLEASE RETURN COMPLETED APPLICATION TO THE CITY SECRETARY'S OFFICE, TOWN OF SOUTH PADRE ISLAND, 4601 PADRE BLVD., SOUTH PADRE ISLAND, TX 78597 OR FAX 956.761.3888.

6-20



Town of South Padre Island – Boards and Commissions Questionnaire

4601 Padre Blvd.
South Padre Island, TX 78597

Phone: 956.761.6456
Fax: 956.761.3888

APPLICANT INFORMATION

Last Name: Nixon First: Robert M.I.: L Date: 9-17-10

Street Address: 22 Augusta Drive Apartment/Unit #: _____

City: Laguna Vista State: TX Zip: 78578

Phone: 956-433-1472 E-mail Address: robaruo2000@gmail.com

Occupation (Place of Business): Manager, Recoil, Inc. (Gravity Park) Phone: 956-761-8588

Are you a citizen of the United States? Yes No

Have you ever been convicted of a felony? Yes No If yes, please explain _____

Have you ever been convicted of, received probation or deferred adjudication for any offense that was not a felony? Yes No If yes, please explain: D.U.I.

Do you have a current Driver's License? Yes No

Have you been a resident of the Town of South Padre Island for at least six (6) months prior to the date of application? Yes No

If qualified, are you a registered South Padre Island voter? Yes No

Are you an adversary party to pending litigation against the Town of South Padre Island? Have you ever been an adversary part to litigation against the Town of South Padre Island? Yes No If yes, please explain: _____

Are you an employee or a business associate of either an adversary party or a representative of an adversary party in any past or pending litigation against the Town of South Padre Island, other than an eminent domain proceeding? Yes No If yes, please explain: _____

Are you an employee or a business associate of either an adversary party or a representative of an adversary party that has a pecuniary interest in any past or pending litigation or claim against the Town of South Padre Island, other than an eminent domain proceeding? Yes No If yes, please explain: _____

Are you in arrears on any Town of South Padre Island taxes, water service charge or other obligations owned to the Town of South Padre Island? Yes No If yes, please explain: _____

Provide All Information Requested: INCOMPLETE APPLICATIONS WILL NOT BE CONSIDERED FOR BOARD/COMMISSION OPPORTUNITIES. Your complete application form will be maintained in our active files for six(6) months from the date of the application. I understand that should I not be appointed to the Town of South Padre Island board and commission, this application and any other records obtained, collected or otherwise prepared regarding this application shall be maintained in accordance with the Texas Public Information Act and the Town of South Padre island's document retention schedule.

6-21

DISCLAIMER AND SIGNATURE

I certify that my answers are true and complete. I understand that the information contained in this application may be considered, among other criteria, qualifications and/or information, by the City Council in its evaluation for the position being sought. I further understand that should I be appointed to any Town of South Padre Island commission, I serve at the pleasure of the Town Board of Aldermen and may be removed from said position at any time and for any reason or no reason at all, with or without notice. I also understand that should I be appointed to a Town of South Padre Island Board or Commission, I must be responsible for a creditable record of attendance and performance. If this application leads to my appointment to a position on a Town of South Padre Island Board or Commission, I understand that false or misleading information in my application may result in my removal from the position.



Signature

9-17-10

Date

6-22

Convention and Authority Board

3 Positions expiring (Tourism Related, Condominium, Limited Service Hotel Industry)

Incumbents requesting another term:

-

New Applications:

- Jacky Conrad
- Joe Ricco
- Daniel Salazar
- Lynne Tate
- Sean Till
- Peggy Trahan

**CANDIDATE APPLICATION FORM
FOR COUNCIL-APPOINTED BOARDS, COMMITTEES &
COMMISSIONS**

Information disclosed on this application or any other attached document may be disclosed in public meetings. Please print clearly.

Board Preference 1: Parks & Recreation

Board Preference 2: CVA

Name: Jacky Conrad

Home Address: 218 W. Esperanza

City: SPI, TX Zip: 78597 SPI Resident: 5 years

Home Telephone: 956-772-1974 Home Fax: 210-568-4127

Home E-Mail: jacky at jam @ aol.com

Profession: Headhunter

Business Name: Jam M Recruiting

Business Address: 218 W. Esperanza

City: SPI State: TX Zip: 78597

Business Telephone: 956-772-1974

Business E-Mail: jacky@jamrecruiting.com

Special Knowledge or Experience applicable to City or Board/Commission Function:

I have worked on many community events for SPI. I have been the lead on Jolly Days, 4th of July Parade, Christmas Parade, Breakfast with Santa assisted in many
Other Information (Civic Activities): SPI Business Coalition member, Vice President of Laguna Madre Humane Society, SPI Business Website Technology Committee, EDC Search Committee for BNC manage

I verify that the information I have provided in this application to be true and correct. I also acknowledge that this information may be made available to the public.

Jacky Conrad
Signature

9-29-2010
Date

PLEASE RETURN COMPLETED APPLICATION TO THE CITY SECRETARY'S OFFICE, TOWN OF SOUTH PADRE ISLAND, 4601 PADRE BLVD., SOUTH PADRE ISLAND, TX 78597 OR FAX 956.761.3888. b-24

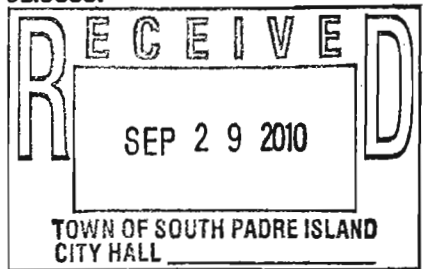



Town of South Padre Island – Boards and Commissions Questionnaire
 4601 Padre Blvd. Phone: 956.761.6456
 South Padre Island, TX 78597 Fax: 956.761.3888

APPLICANT INFORMATION

Last Name: Conrad First: Jacky M.I.: K Date: 9-29-2010

Street Address: 218 W. Esperanza Apartment/Unit #: _____

City: SPI State: TX Zip: 78597

Phone: 956-772-1974 E-mail Address: jacky at jam@aol.com

Occupation (Place of Business): Headhunter Phone: 956-772-1974

Are you a citizen of the United States? Yes No

Have you ever been convicted of a felony? Yes No If yes, please explain _____

Have you ever been convicted of, received probation or deferred adjudication for any offense that was not a felony? Yes No If yes, please explain: _____

Do you have a current Driver's License? Yes No

Have you been a resident of the Town of South Padre Island for at least six (6) months prior to the date of application? Yes No

If qualified, are you a registered South Padre Island voter? Yes No

Are you an adversary party to pending litigation against the Town of South Padre Island? Have you ever been an adversary part to litigation against the Town of South Padre Island? Yes No If yes, please explain: _____

Are you an employee or a business associate of either an adversary party or a representative of an adversary party in any past or pending litigation against the Town of South Padre Island, other than an eminent domain proceeding? Yes No If yes, please explain: _____

Are you an employee or a business associate of either an adversary party or a representative of an adversary party that has a pecuniary interest in any past or pending litigation or claim against the Town of South Padre Island, other than an eminent domain proceeding? Yes No If yes, please explain: _____

Are you in arrears on any Town of South Padre Island taxes, water service charge or other obligations owned to the Town of South Padre Island? Yes No If yes, please explain: _____

Provide All Information Requested: INCOMPLETE APPLICATIONS WILL NOT BE CONSIDERED FOR BOARD/COMMISSION OPPORTUNITIES. Your complete application form will be maintained in our active files for six(6) months from the date of the application. I understand that should I not be appointed to the Town of South Padre Island board and commission, this application and any other records obtained, collected or otherwise prepared regarding this application shall be maintained in accordance with the Texas Public Information Act and the Town of South Padre island's document retention schedule.

6-25

DISCLAIMER AND SIGNATURE

I certify that my answers are true and complete. I understand that the information contained in this application may be considered, among other criteria, qualifications and/or information, by the City Council in its evaluation for the position being sought. I further understand that should I be appointed to any Town of South Padre Island commission, I serve at the pleasure of the Town Board of Aldermen and may be removed from said position at any time and for any reason or no reason at all, with or without notice. I also understand that should I be appointed to a Town of South Padre Island Board or Commission, I must be responsible for a creditable record of attendance and performance. If this application leads to my appointment to a position on a Town of South Padre Island Board or Commission, I understand that false or misleading information in my application may result in my removal from the position.

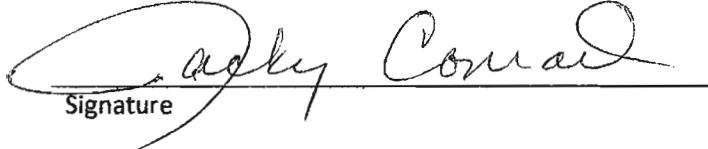
Signature

9-29-2010
Date

6-26

**CANDIDATE APPLICATION FORM
FOR COUNCIL-APPOINTED BOARDS, COMMITTEES &
COMMISSIONS**

Information disclosed on this application or any other attached document may be disclosed in public meetings. Please print clearly.

Board Preference 1: Convention And Visitors Authority Board

Board Preference 2: _____

Name: Joseph M Ricco

Home Address: 213 West Gardenia

City: South Padre Island Zip: 78597 SPI Resident: 14 years

Home Telephone: 761-5274 Home Fax: _____

Home E-Mail: Redrumjoe2@aol.com

Profession: General Manager

Business Name: Louie's Backyard

Business Address: 2305 Laguna Blvd

City: South Padre Is. State: Tx

Business Telephone: 956 761-6406

Business E-Mail: Redrumjoe2@aol.com

Special Knowledge or Experience applicable to City Committee Function: _____

I have been involved in Hospitality Management on the Island since 1995. I currently oversee all print, internet and social media advertising for our company in addition to all daily Management operations.

Other Information (Civic Activities): Leadership Laguna Madre Class V; Texas Scholars

Presenter, Chair person for The Taste of the Island for 5 years, Laguna Madre Boys & Girls Club Fund raiser, Special Events Committee for 6 years, Laguna Madre Habitat for Humanity

I verify that the information I have provided in this application to be true and correct. I also acknowledge that this information may be made available to the public.

Signature: Joseph M Ricco

Date: 09/20/10

PLEASE RETURN COMPLETED APPLICATION TO THE CITY SECRETARY'S OFFICE, CITY OF SOUTH PADRE ISLAND, 4601 PADRE BLVD., SOUTH PADRE ISLAND, TX 78597; EMAIL SHILL@SOUTHPADRETEXAS.GOV OR FAX 956/761-3888.

6-29



City of South Padre Island – Committees, Boards and Commissions

Questionnaire

4601 Padre Blvd.
South Padre Island, TX 78597

Phone: 956/761-6456

Fax: 956/761-3888

APPLICANT INFORMATION

Last Name: Ricco First: Joseph M.I.: M Date: 09/20/10
Street Address: 213 West Gardenia PO Box 3143 Apartment/Unit #:
City: South Padre Island State: Tx Zip: 78597
Phone: 956 266 3550 E-mail Address: Redrum_joe2@aol.com
Occupation (Place of Business): General Manager Lovie's Backyard Phone: 761 6406

Are you a citizen of the United States? Yes No

Have you ever been convicted of a felony? Yes No If yes, please explain _____

Have you ever been convicted of, received probation or deferred adjudication for any offense that was not a felony? Yes No If yes, please explain: _____

Do you have a current Driver's License? Yes No

Have you been a resident of the City of South Padre Island for at least six (6) months prior to the date of application? Yes No

If qualified, are you a registered South Padre Island voter? Yes No

Are you an adversary party to pending litigation against the City of South Padre Island? Have you ever been an adversary party to litigation against the City of South Padre Island? Yes No If yes, please explain: _____

Are you an employee or a business associate of either an adversary party or a representative of an adversary party in any past or pending litigation against the City of South Padre Island, other than an eminent domain proceeding? Yes No If yes, please explain: _____

Are you an employee or a business associate of either an adversary party or a representative of an adversary party that has a pecuniary interest in any past or pending litigation or claim against the City of South Padre Island, other than an eminent domain proceeding? Yes No If yes, please explain: _____

Are you in arrears on any City of South Padre Island taxes, water service charge or other obligations owned to the City of South Padre Island? Yes No If yes, please explain: _____

Provide All Information Requested: INCOMPLETE APPLICATIONS WILL NOT BE CONSIDERED FOR COMMITTEE, BOARD OR COMMISSION OPPORTUNITIES. Your complete application form will be maintained in our active files for six (6) months from the date of the application. I understand that should I not be appointed to the City of South Padre Island committee, board or commission, this application and any other records obtained, collected or otherwise prepared regarding this application shall be maintained in accordance with the Texas Public Information Act and the City of South Padre Island's document retention schedule.

4-28

DISCLAIMER AND SIGNATURE

I certify that my answers are true and complete. I understand that the information contained in this application may be considered, among other criteria, qualifications and/or information, by the City Council in its evaluation for the position being sought. I further understand that should I be appointed to any City of South Padre Island committee, board, or commission, I serve at the pleasure of the South Padre Island City Council and may be removed from said position at any time and for any reason or no reason at all, with or without notice. I also understand that should I be appointed to a City of South Padre Island Board or Commission, I must be responsible for a creditable record of attendance and performance. If this application leads to my appointment to a position on a City of South Padre Island Committee, Board or Commission, I understand that false or misleading information in my application may result in my removal from the position.

Signature Joseph M. Burt

Date 09/20/10

6-29

**CANDIDATE APPLICATION FORM
FOR COUNCIL-APPOINTED BOARDS, COMMITTEES &
COMMISSIONS**

Information disclosed on this application or any other attached document may be disclosed in public meetings. Please print clearly.

Board Preference 1: Convention and Visitors Authority Board
Board Preference 2: _____

Name: Daniel Salazar

Home Address: 39770 Pisaca Blvd

City: Los Fresnos, TX Zip: 78566 SPI Resident: 21 years

Home Telephone: 956-233-5371 Home Fax: 956-233-5397

Home E-Mail: d.salazar@islagrand.com

Profession: General Manager

Business Name: Isla Grand Beach Resort

Business Address: 500 Padre Blvd

City: South Padre Island State: TX Zip: 78597

Business Telephone: 956-761-6511 x 5892

Business E-Mail: d.salazar@islagrand.com

Special Knowledge or Experience applicable to City or Board/Commission Function: _____

Bachelor of Science Degree in Hotel & Restaurant & Minor Psychology
11 years in General Management of the Radisson Resort / Isla Grand
Beach Resort.

Other Information (Civic Activities): Board of Directors for South Padre Island

Chamber of Commerce 2004-2008

Laguna Madre Education Foundation.

I verify that the information I have provided in this application to be true and correct. I also acknowledge that this information may be made available to the public.

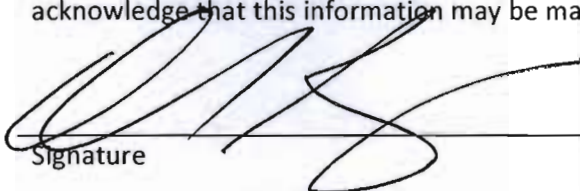
Signature

8-20-10
Date

PLEASE RETURN COMPLETED APPLICATION TO THE CITY SECRETARY'S OFFICE, TOWN OF SOUTH PADRE ISLAND, 4601 PADRE BLVD., SOUTH PADRE ISLAND, TX 78597 OR FAX 956.761.3888.

6-30



Town of South Padre Island – Boards and Commissions Questionnaire
 4601 Padre Blvd. Phone: 956.761.6456
 South Padre Island, TX 78597 Fax: 956.761.3888

APPLICANT INFORMATION

Last Name: Salazar First: Daniel M.I.: R. Date: 8-20-10

Street Address: 39770 Resaca Blvd Apartment/Unit #:

City: Las Brisas State: TX Zip: 78566

Phone: 956-433-6474 E-mail Address: dsalazar@isla grand.com

Occupation (Place of Business): General Manager - Isla Grand Phone: 956-547-5892

Are you a citizen of the United States? Yes No

Have you ever been convicted of a felony? Yes No If yes, please explain _____

Have you ever been convicted of, received probation or deferred adjudication for any offense that was not a felony? Yes If yes, please explain: _____
 No

Do you have a current Driver's License? Yes No

Have you been a resident of the Town of South Padre Island for at least six (6) months prior to the date of application? Yes No 1978-1999

If qualified, are you a registered South Padre Island voter? Yes No

Are you an adversary party to pending litigation against the Town of South Padre Island? Yes If yes, please explain: _____
 Have you ever been an adversary party to litigation against the Town of South Padre Island? No

Are you an employee or a business associate of either an adversary party or a representative of an adversary party in any past or pending litigation against the Town of South Padre Island, other than an eminent domain proceeding? Yes If yes, please explain: _____
 No

Are you an employee or a business associate of either an adversary party or a representative of an adversary party that has a pecuniary interest in any past or pending litigation or claim against the Town of South Padre Island, other than an eminent domain proceeding? Yes If yes, please explain: _____
 No

Are you in arrears on any Town of South Padre Island taxes, water service charge or other obligations owned to the Town of South Padre Island? Yes If yes, please explain: _____
 No

Provide All Information Requested: INCOMPLETE APPLICATIONS WILL NOT BE CONSIDERED FOR BOARD/COMMISSION OPPORTUNITIES. Your complete application form will be maintained in our active files for six(6) months from the date of the application. I understand that should I not be appointed to the Town of South Padre Island board and commission, this application and any other records obtained, collected or otherwise prepared regarding this application shall be maintained in accordance with the Texas Public Information Act and the Town of South Padre Island's document retention schedule.

6-31

DISCLAIMER AND SIGNATURE

I certify that my answers are true and complete. I understand that the information contained in this application may be considered, among other criteria, qualifications and/or information, by the City Council in its evaluation for the position being sought. I further understand that should I be appointed to any Town of South Padre Island commission, I serve at the pleasure of the Town Board of Aldermen and may be removed from said position at any time and for any reason or no reason at all, with or without notice. I also understand that should I be appointed to a Town of South Padre Island Board or Commission, I must be responsible for a creditable record of attendance and performance. If this application leads to my appointment to a position on a Town of South Padre Island Board or Commission, I understand that false or misleading information in my application may result in my removal from the position.

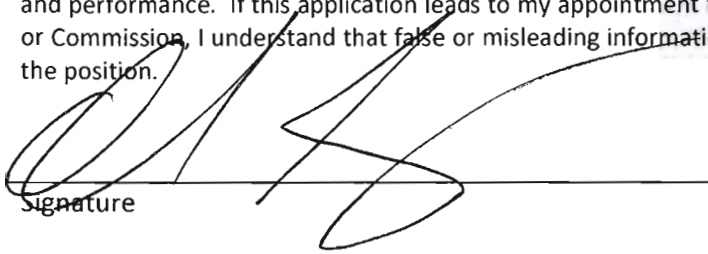
Signature

8-20-10
Date

**CANDIDATE APPLICATION FORM
FOR COUNCIL-APPOINTED BOARDS, COMMITTEES &
COMMISSIONS**

Information disclosed on this application or any other attached document may be disclosed in public meetings. Please print clearly.

Board Preference 1: SPI Convention & Visitors Authority Board
Board Preference 2: _____

Name: LYNNE TATE

Home Address: 2300 Padre #102
mailing - 2200 Padre Blvd.

City: South Padre Island Zip: 78597 SPI Resident: 18 1/2 years

Home Telephone: 956-761-6580 Home Fax: 956-761-1805
office

Home E-Mail: lynne@rqr.pz.com

Profession: Real Estate Broker

Business Name: LYNNE TATE Real Estate

Business Address: 2200 Padre Blvd.

City: South Padre Island State: TX Zip: 78597

Business Telephone: 956-761-1400

Business E-Mail: lynne@lynne.tate.realestate.com

Special Knowledge or Experience applicable to City Committee Function:

sales manager for Sheraton Hotel in Anchorage with the convention center contract for sales, business development coordinator for ^{city of} anchorage

Other Information (Civic Activities): very involved and supportive of community services and organizations with financial support, attendance & volunteer time.

I verify that the information I have provided in this application to be true and correct. I also acknowledge that this information may be made available to the public.

Lynne Tate
Signature

9/28/10
Date

PLEASE RETURN COMPLETED APPLICATION TO THE CITY SECRETARY'S OFFICE, CITY OF SOUTH PADRE ISLAND, 4601 PADRE BLVD., SOUTH PADRE ISLAND, TX 78597; EMAIL SHILL@SOUTHPADRETEXAS.GOV OR FAX 956/761-3888.

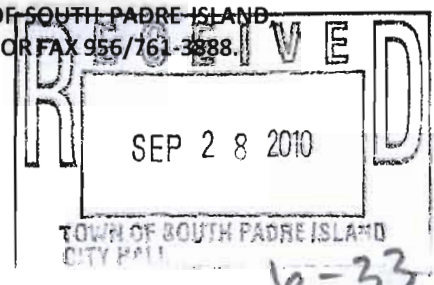



City of South Padre Island – Committees, Boards and Commissions
 Questionnaire
 4601 Padre Blvd.
 South Padre Island, TX 78597

Phone: 956/761-6456
 Fax: 956/761-3888

APPLICANT INFORMATION

Last Name: TATE First: LYNNE M.I.: B. Date: 9/28/10

Street Address: 2200 Padre Blvd. Apartment/Unit #: _____

City: South Padre Island State: TX Zip: 78597

Phone: 956-761-1400 E-mail Address: lynn@lynnetate^{cell}real^{estate}.com
 Occupation (Place of Business): Real Estate BROKER Phone: 956-433-1508

Are you a citizen of the United States? Yes No

Have you ever been convicted of a felony? Yes No If yes, please explain _____

Have you ever been convicted of, received probation or deferred adjudication for any offense that was not a felony? Yes No If yes, please explain: _____

Do you have a current Driver's License? Yes No

Have you been a resident of the City of South Padre Island for at least six (6) months prior to the date of application? Yes No

If qualified, are you a registered South Padre Island voter? Yes No

Are you an adversary party to pending litigation against the City of South Padre Island? Have you ever been an adversary part to litigation against the City of South Padre Island? Yes No If yes, please explain: _____

Are you an employee or a business associate of either an adversary party or a representative of an adversary party in any past or pending litigation against the City of South Padre Island, other than an eminent domain proceeding? Yes No If yes, please explain: _____

Are you an employee or a business associate of either an adversary party or a representative of an adversary party that has a pecuniary interest in any past or pending litigation or claim against the City of South Padre Island, other than an eminent domain proceeding? Yes No If yes, please explain: _____

Are you in arrears on any City of South Padre Island taxes, water service charge or other obligations owned to the City of South Padre Island? Yes No If yes, please explain: _____

Provide All Information Requested: INCOMPLETE APPLICATIONS WILL NOT BE CONSIDERED FOR COMMITTEE, BOARD OR COMMISSION OPPORTUNITIES. Your complete application form will be maintained in our active files for six (6) months from the date of the application. I understand that should I not be appointed to the City of South Padre Island committee, board or commission, this application and any other records obtained, collected or otherwise prepared regarding this application shall be maintained in accordance with the Texas Public Information Act and the City of South Padre Island's document retention schedule.

6-34

DISCLAIMER AND SIGNATURE

I certify that my answers are true and complete. I understand that the information contained in this application may be considered, among other criteria, qualifications and/or information, by the City Council in its evaluation for the position being sought. I further understand that should I be appointed to any City of South Padre Island committee, board, or commission, I serve at the pleasure of the South Padre Island City Council and may be removed from said position at any time and for any reason or no reason at all, with or without notice. I also understand that should I be appointed to a City of South Padre Island Board or Commission, I must be responsible for a creditable record of attendance and performance. If this application leads to my appointment to a position on a City of South Padre Island Committee, Board or Commission, I understand that false or misleading information in my application may result in my removal from the position.

Lynne Tate
Signature

9/28/10
Date

**CANDIDATE APPLICATION FORM
FOR COUNCIL-APPOINTED BOARDS, COMMITTEES &
COMMISSIONS**

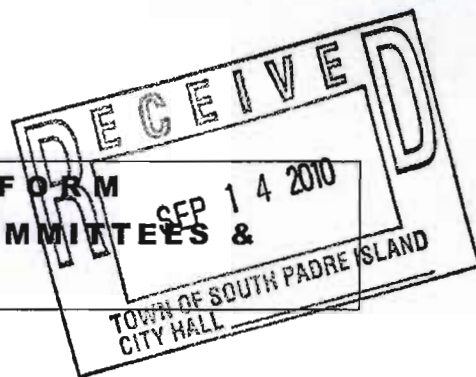

Information disclosed on this application or any other attached document may be disclosed in public meetings. Please print clearly.

Board Preference 1: Convention & Visitor Authority

Board Preference 2: _____

Name: Sean M. Till

Home Address: 300 S. Garcia St.

City: Port Isabel Zip: TX SPI Resident: _____ years

Home Telephone: 956-299-4335 Home Fax: _____

Home E-Mail: sean@islandgeek.com

Profession: Information Technology

Business Name: Island Geek

Business Address: 104 W. Bahama St.

City: South Padre Island State: TX Zip: 78597

Business Telephone: 956-761-3333

Business E-Mail: sean@islandgeek.com

Special Knowledge or Experience applicable to City or Board/Commission Function: _____

Information Technology, specializing in the hospitality industry.

Online marketing experience with South Padre Island businesses.

Other Information (Civic Activities): _____

I verify that the information I have provided in this application to be true and correct. I also acknowledge that this information may be made available to the public.

Signature

9/1/10
Date

PLEASE RETURN COMPLETED APPLICATION TO THE CITY SECRETARY'S OFFICE, TOWN OF SOUTH PADRE ISLAND, 4601 PADRE BLVD., SOUTH PADRE ISLAND, TX 78597 OR FAX 956.761.3888.

6-36



Town of South Padre Island – Boards and Commissions Questionnaire
 4601 Padre Blvd. Phone: 956.761.6456
 South Padre Island, TX 78597 Fax: 956.761.3888

APPLICANT INFORMATION

Last Name: Till First: Sean M.I.: M Date: 9/1/10
 Street Address: 104 W. Bahama St Apartment/Unit #: A
 City: South Padre Island State: TX Zip: 78597
 Phone: 956-761-3333 E-mail Address: sean@islandgeek.com
 Occupation (Place of Business): Island Geek Phone: 956-761-3333

Are you a citizen of the United States? Yes No

Have you ever been convicted of a felony? Yes No If yes, please explain _____

Have you ever been convicted of, received probation or deferred adjudication for any offense that was not a felony? Yes No
 If yes, please explain: Deferred adjudication for traffic violation

Do you have a current Driver's License? Yes No

Have you been a resident of the Town of South Padre Island for at least six (6) months prior to the date of application? Yes No

If qualified, are you a registered South Padre Island voter? Yes No

Are you an adversary party to pending litigation against the Town of South Padre Island? Have you ever been an adversary part to litigation against the Town of South Padre Island? Yes No
 If yes, please explain: _____

Are you an employee or a business associate of either an adversary party or a representative of an adversary party in any past or pending litigation against the Town of South Padre Island, other than an eminent domain proceeding? Yes No
 If yes, please explain: _____

Are you an employee or a business associate of either an adversary party or a representative of an adversary party that has a pecuniary interest in any past or pending litigation or claim against the Town of South Padre Island, other than an eminent domain proceeding? Yes No
 If yes, please explain: _____

Are you in arrears on any Town of South Padre Island taxes, water service charge or other obligations owned to the Town of South Padre Island? Yes No
 If yes, please explain: _____

Provide All Information Requested: INCOMPLETE APPLICATIONS WILL NOT BE CONSIDERED FOR BOARD/COMMISSION OPPORTUNITIES. Your complete application form will be maintained in our active files for six(6) months from the date of the application. I understand that should I not be appointed to the Town of South Padre Island board and commission, this application and any other records obtained, collected or otherwise prepared regarding this application shall be maintained in accordance with the Texas Public Information Act and the Town of South Padre island's document retention schedule.

6-37

DISCLAIMER AND SIGNATURE

I certify that my answers are true and complete. I understand that the information contained in this application may be considered, among other criteria, qualifications and/or information, by the City Council in its evaluation for the position being sought. I further understand that should I be appointed to any Town of South Padre Island commission, I serve at the pleasure of the Town Board of Aldermen and may be removed from said position at any time and for any reason or no reason at all, with or without notice. I also understand that should I be appointed to a Town of South Padre island Board or Commission, I must be responsible for a creditable record of attendance and performance. If this application leads to my appointment to a position on a Town of South Padre Island Board or Commission, I understand that false or misleading information in my application may result in my removal from the position.

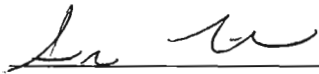

Signature

9/1/10

Date

**CANDIDATE APPLICATION FORM
FOR COUNCIL-APPOINTED BOARDS, COMMITTEES &
COMMISSIONS**

Information disclosed on this application or any other attached document may be disclosed in public meetings. Please print clearly.

Board Preference 1: CVA

Board Preference 2: _____

Name: PEGGY TRAHAN

Home Address: 3000 GULF BLVD.

City: SOUTH PADRE ISLAND Zip: 78597 SPI Resident: 25 years

Home Telephone: 956-761-1483 Home Fax: 956-761-1483 (Cell: 299-1719)

Home E-Mail: PEGTRAHAN@AOL.COM

Profession: VOLUNTEER

Business Name: _____

Business Address: _____

City: _____ State: _____ Zip: _____

Business Telephone: _____

Business E-Mail: _____

Special Knowledge or Experience applicable to City or Board/Commission Function: FORMER MAYOR;

FORMER MEMBER OF CVB BOARD IN 1992, BUT HAD TO RESIGN WHEN ELECTED MAYOR; WHEN SATELLITE TV PROGRAM DIRECTOR AT THE ARMY HEALTH SERVICES COMMAND, PROMOTED PROGRAMS NATIONWIDE.

Other Information (Civic Activities): EDC BOARD, 1994-5; RIO GRANDE VALLEY

ECONOMIC BD; V.P. TML SMALL CITIES' BD; V.P. REGIONAL RETAIL BOARD;

PUBLICITY CHAIR, RGV VALLEY EMERGENCY MEET; DPRE; CHAIRMAN, PIRATE DAYS, 1994, 95.

I verify that the information I have provided in this application to be true and correct. I also acknowledge that this information may be made available to the public.

Peggy Trahan
Signature

9/29/10
Date

EDC Bd.
2007-10.
BNC Bd.
2007-

PLEASE RETURN COMPLETED APPLICATION TO THE CITY SECRETARY'S OFFICE, TOWN OF SOUTH PADRE ISLAND, 4601 PADRE BLVD., SOUTH PADRE ISLAND, TX 78597 OR FAX 956.761.3888.



Town of South Padre Island – Boards and Commissions Questionnaire
 4601 Padre Blvd. Phone: 956.761.6456
 South Padre Island, TX 78597 Fax: 956.761.3888

APPLICANT INFORMATION

Last Name: TRAHAN First: MARGARET ("PEGGY") M.I.: F. Date: 9/29/10
 Street Address: 3000 GULF BLVD. Apartment/Unit #: 503
 City: SOUTH PADRE ISLAND State: TX Zip: 78597
 Phone: (956) 761-1483 E-mail Address: PEGTRAHAN@AOL.COM
 Occupation (Place of Business): N/A Phone: CELL: 299-1719

Are you a citizen of the United States? Yes No

Have you ever been convicted of a felony? Yes No If yes, please explain _____

Have you ever been convicted of, received probation or deferred adjudication for any offense that was not a felony? Yes No If yes, please explain: _____

Do you have a current Driver's License? Yes No

Have you been a resident of the Town of South Padre Island for at least six (6) months prior to the date of application? Yes No

If qualified, are you a registered South Padre Island voter? Yes No

Are you an adversary party to pending litigation against the Town of South Padre Island? Yes No If yes, please explain: _____

Are you an employee or a business associate of either an adversary party or a representative of an adversary party in any past or pending litigation against the Town of South Padre Island, other than an eminent domain proceeding? Yes No If yes, please explain: _____

Are you an employee or a business associate of either an adversary party or a representative of an adversary party that has a pecuniary interest in any past or pending litigation or claim against the Town of South Padre Island, other than an eminent domain proceeding? Yes No If yes, please explain: _____

Are you in arrears on any Town of South Padre Island taxes, water service charge or other obligations owned to the Town of South Padre Island? Yes No If yes, please explain: _____

Provide All Information Requested: INCOMPLETE APPLICATIONS WILL NOT BE CONSIDERED FOR BOARD/COMMISSION OPPORTUNITIES. Your complete application form will be maintained in our active files for six(6) months from the date of the application. I understand that should I not be appointed to the Town of South Padre Island board and commission, this application and any other records obtained, collected or otherwise prepared regarding this application shall be maintained in accordance with the Texas Public Information Act and the Town of South Padre island's document retention schedule.

6-40

Development Standards Review Task Force

9 New Positions

New Applications:

- Joe Baker
- Beth Fedigan
- Bob Fudge
- James Helms
- Jody Hughes
- George Lesieutre
- Joe Logan (Application will be submitted Monday)
- Nancy Moyer
- Steve O'Neil

**CANDIDATE APPLICATION FORM
FOR COUNCIL-APPOINTED BOARDS, COMMITTEES &
COMMISSIONS**

Information disclosed on this application or any other attached document may be disclosed in public meetings. Please print clearly.

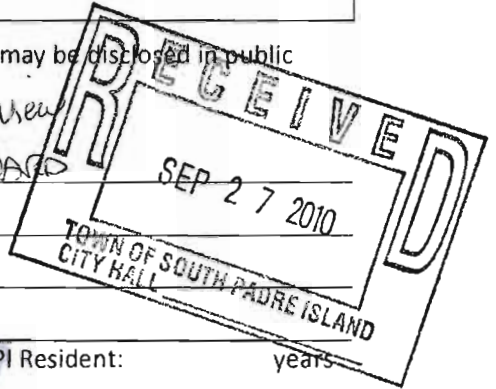

Board Preference 1: Development Standards Review
New Form Base Code Board

Board Preference 2: _____

Name: JOE BAKER

Home Address: 116 Nth SAN ROMAN

City: BAYVIEW TX Zip: 78566 SPI Resident: _____ years

Home Telephone: 1-956-233-5455 Home Fax: 1-956-233-5455

Home E-Mail: COASTCASAS@AOL.COM

Profession: Residential Home Building (New Construction)

Business Name: COASTAL CONTRACTORS

Business Address: 116 Nth SAN ROMAN

City: BAYVIEW TX State: TX Zip: 78566

Business Telephone: 1-956-233-5455

Business E-Mail: COASTCASAS@AOL.COM

Special Knowledge or Experience applicable to City Committee Function:

CURRENT FORM BASE CODE MEMBER SPI

FORMER CHAIRMAN Padre Blvd Beautification SPI

Other Information (Civic Activities): Many Previous Civic Activities

in TEXAS, Georgia, Mississippi, California, Washington St.

I verify that the information I have provided in this application to be true and correct. I also acknowledge that this information may be made available to the public.

Signature: [Handwritten Signature]

Date: 9-22-10

PLEASE RETURN COMPLETED APPLICATION TO THE CITY SECRETARY'S OFFICE, CITY OF SOUTH PADRE ISLAND, 4601 PADRE BLVD., SOUTH PADRE ISLAND, TX 78597; EMAIL SHILL@SOUTHPADRETEXAS.GOV OR FAX 956/761-3888.

6-42



City of South Padre Island – Committees, Boards and Commissions
Questionnaire

4601 Padre Blvd.
South Padre Island, TX 78597

Phone: 956/761-6456

Fax: 956/761-3888

APPLICANT INFORMATION

Last Name: BAKER First: JOE M.I.: E Date: 9-22-10

Street Address: 116 NTH SAN ROMAN Apartment/Unit #:

City: BAYVIEW State: TX Zip: 78566

Phone: 1-956-233-5455 E-mail Address: COASTCASAS2@AOL.COM

Occupation (Place of Business): Homebuilding Company Phone: 1-956-233-5455

Are you a citizen of the United States? Yes No

Have you ever been convicted of a felony? Yes No If yes, please explain _____

Have you ever been convicted of, received probation or deferred adjudication for any offense that was not a felony? Yes No If yes, please explain: _____

Do you have a current Driver's License? Yes No

Have you been a resident of the City of South Padre Island for at least six (6) months prior to the date of application? Yes No

If qualified, are you a registered South Padre Island voter? Yes No

*OWN PROPERTY ON SPI
AND BUSINESS CONDUCTED
ON SOUTH PADRE ISLAND
CLOSED RECENT SPI OFFICE*

Are you an adversary party to pending litigation against the City of South Padre Island? Have you ever been an adversary part to litigation against the City of South Padre Island? Yes No If yes, please explain: _____

Are you an employee or a business associate of either an adversary party or a representative of an adversary party in any past or pending litigation against the City of South Padre Island, other than an eminent domain proceeding? Yes No If yes, please explain: _____

Are you an employee or a business associate of either an adversary party or a representative of an adversary party that has a pecuniary interest in any past or pending litigation or claim against the City of South Padre Island, other than an eminent domain proceeding? Yes No If yes, please explain: _____

Are you in arrears on any City of South Padre Island taxes, water service charge or other obligations owned to the City of South Padre Island? Yes No If yes, please explain: _____

Provide All Information Requested: INCOMPLETE APPLICATIONS WILL NOT BE CONSIDERED FOR COMMITTEE, BOARD OR COMMISSION OPPORTUNITIES. Your complete application form will be maintained in our active files for six (6) months from the date of the application. I understand that should I not be appointed to the City of South Padre Island committee, board or commission, this application and any other records obtained, collected or otherwise prepared regarding this application shall be maintained in accordance with the Texas Public Information Act and the City of South Padre Island's document retention schedule.

DISCLAIMER AND SIGNATURE

I certify that my answers are true and complete. I understand that the information contained in this application may be considered, among other criteria, qualifications and/or information, by the City Council in its evaluation for the position being sought. I further understand that should I be appointed to any City of South Padre Island committee, board, or commission, I serve at the pleasure of the South Padre Island City Council and may be removed from said position at any time and for any reason or no reason at all, with or without notice. I also understand that should I be appointed to a City of South Padre Island Board or Commission, I must be responsible for a creditable record of attendance and performance. If this application leads to my appointment to a position on a City of South Padre Island Committee, Board or Commission, I understand that false or misleading information in my application may result in my removal from the position.

Signature

9-22-10
Date

**CANDIDATE APPLICATION FORM
FOR COUNCIL-APPOINTED BOARDS, COMMITTEES &
COMMISSIONS**

Information disclosed on this application or any other attached document may be disclosed in public meetings. Please print clearly.

Board Preference 1: PLANNING AND ZONING COMMISSION

Board Preference 2: DEVELOPMENT STANDARDS REVIEW TASK FORCE

Name: JAMES C. HELMS

Home Address: 115 EAST DALMETTO

City: SOUTH PADRE ISLAND Zip: 78597 SPI Resident: 10 years

Home Telephone: 7611932 Home Fax: _____

Home E-Mail: _____

Profession: RETIRED

Business Name: _____

Business Address: _____

City: _____ State: _____ Zip: _____

Business Telephone: _____

Business E-Mail: _____

Special Knowledge or Experience applicable to City Committee Function: _____
ISLAND

Other Information (Civic Activities): _____

I verify that the information I have provided in this application to be true and correct. I also acknowledge that this information may be made available to the public.

[Signature]
Signature

9/27/10
Date

PLEASE RETURN COMPLETED APPLICATION TO THE CITY SECRETARY'S OFFICE, CITY OF SOUTH PADRE ISLAND, 4601 PADRE BLVD., SOUTH PADRE ISLAND, TX 78597; EMAIL SHILL@SOUTHPADRETEXAS.GOV OR FAX 956/761-3888.

**CANDIDATE APPLICATION FORM
FOR COUNCIL-APPOINTED BOARDS, COMMITTEES &
COMMISSIONS**

Information disclosed on this application or any other attached document may be disclosed in public meetings. Please print clearly.

Board Preference 1: Development Standard Review Task Force
Board Preference 2: _____

Name: Beth Fedigan

Home Address: 211 W. CAMPECHE (PO Box 3244)

City: S.P.I. TEXAS Zip: 78597 SPI Resident: 18 years

Home Telephone: 956-761-4142 Home Fax: 956-761-6766

Home E-Mail: olive046@aol.com

Profession: Artist

Business Name: B. FEDIGAN ART

Business Address: POB. 3244

City: S.P.I. State: TX Zip: 78597

Business Telephone: 956-739-2903

Business E-Mail: olive046@aol.com

Special Knowledge or Experience applicable to City or Board/Commission Function: previously served: Padre Revitalization Comm. and Form Base Code, CIP

Other Information (Civic Activities): _____

I verify that the information I have provided in this application to be true and correct. I also acknowledge that this information may be made available to the public.

[Signature]
Signature

9 28 10
Date

PLEASE RETURN COMPLETED APPLICATION TO THE CITY SECRETARY'S OFFICE, TOWN OF SOUTH PADRE ISLAND, 4601 PADRE BLVD., SOUTH PADRE ISLAND, TX 78597 OR FAX 956.761.3888

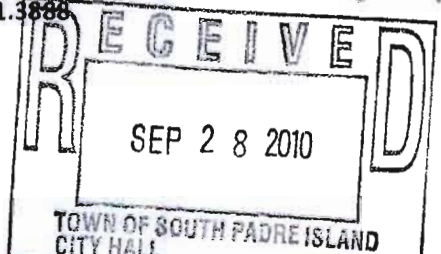

6-46



Town of South Padre Island – Boards and Commissions Questionnaire
 4601 Padre Blvd. Phone: 956.761.6456
 South Padre Island, TX 78597 Fax: 956.761.3888

APPLICANT INFORMATION

Last Name: Fedigan First: Beth M.I.: W Date: 9-28-10
 Street Address: 211 W. CALPECH (POB 3244) Apartment/Unit #: _____
 City: S. Padre Island State: TX Zip: 78597
 Phone: 956-761-4142 E-mail Address: Olive046@AOL.COM
 Occupation (Place of Business): AR Phone: _____

Are you a citizen of the United States? Yes No

Have you ever been convicted of a felony? Yes No If yes, please explain _____

Have you ever been convicted of, received probation or deferred adjudication for any offense that was not a felony? Yes No If yes, please explain: _____

Do you have a current Driver's License? Yes No

Have you been a resident of the Town of South Padre Island for at least six (6) months prior to the date of application? Yes No

If qualified, are you a registered South Padre Island voter? Yes No

Are you an adversary party to pending litigation against the Town of South Padre Island? Yes No If yes, please explain: _____

Are you an employee or a business associate of either an adversary party or a representative of an adversary party in any past or pending litigation against the Town of South Padre Island, other than an eminent domain proceeding? Yes No If yes, please explain: _____

Are you an employee or a business associate of either an adversary party or a representative of an adversary party that has a pecuniary interest in any past or pending litigation or claim against the Town of South Padre Island, other than an eminent domain proceeding? Yes No If yes, please explain: _____

Are you in arrears on any Town of South Padre Island taxes, water service charge or other obligations owned to the Town of South Padre Island? Yes No If yes, please explain: _____

Provide All Information Requested: INCOMPLETE APPLICATIONS WILL NOT BE CONSIDERED FOR BOARD/COMMISSION OPPORTUNITIES. Your complete application form will be maintained in our active files for six(6) months from the date of the application. I understand that should I not be appointed to the Town of South Padre Island board and commission, this application and any other records obtained, collected or otherwise prepared regarding this application shall be maintained in accordance with the Texas Public Information Act and the Town of South Padre island's document retention schedule.

6-47

DISCLAIMER AND SIGNATURE

I certify that my answers are true and complete. I understand that the information contained in this application may be considered, among other criteria, qualifications and/or information, by the City Council in its evaluation for the position being sought. I further understand that should I be appointed to any Town of South Padre Island commission, I serve at the pleasure of the Town Board of Aldermen and may be removed from said position at any time and for any reason or no reason at all, with or without notice. I also understand that should I be appointed to a Town of South Padre island Board or Commission, I must be responsible for a creditable record of attendance and performance. If this application leads to my appointment to a position on a Town of South Padre Island Board or Commission, I understand that false or misleading information in my application may result in my removal from the position.

Signature

A handwritten signature in black ink, appearing to read "Steve Johnson", written over a horizontal line.

Date

9-28-10

6-48

DSRTF

**CANDIDATE APPLICATION FORM
FOR COUNCIL-APPOINTED BOARDS, COMMITTEES &
COMMISSIONS**

Information disclosed on this application or any other attached document may be disclosed in public meetings. Please print clearly.

Board Preference 1: Planning and Zoning Commission

Board Preference 2: Development Standards Review Task Force

Name: Robert A. Fudge

Home Address: 200 West Atol Street, PO Box 3854

City: South Padre Island Zip: 78597 SPI Resident: 12 years

Home Telephone: 956-772-1305 Home Fax: 956-772-1303

Home E-Mail: rfudge@rgv.rr.com

Profession: Professional Engineer

Business Name: Fudge Consulting, PLLC

Business Address: PO Box 3854

City: South Padre Island State: Texas Zip: 78597

Business Telephone: 956-433-9001

Business E-Mail: bob@fudgeconsulting.com

Special Knowledge or Experience applicable to City or Board/Commission Function:

Please see attachment

Other Information (Civic Activities):

Please see attachment

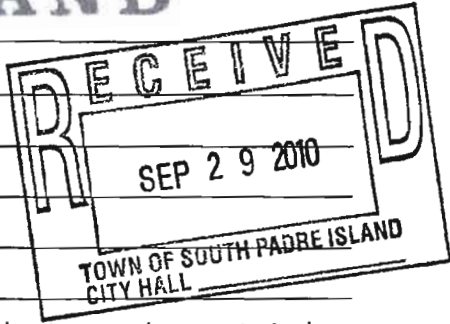

I verify that the information I have provided in this application to be true and correct. I also acknowledge that this information may be made available to the public.

Robert A. Fudge
Signature

September 27, 2010
Date

PLEASE RETURN COMPLETED APPLICATION TO THE CITY SECRETARY'S OFFICE, TOWN OF SOUTH PADRE ISLAND, 4601 PADRE BLVD., SOUTH PADRE ISLAND, TX 78597 OR FAX 956.761.3888.

6-49

**Candidate Application Form
Attachment "A"
For
Robert A. Fudge, P.E.**

Special Knowledge or Experience applicable to City or Board/Commission Function:

- Current Chairman of the Form Based Code Commission
- Current Chairman of Planning and Zoning Commission
- Member of Padre Boulevard Revitalization Committee
- Member of Padre Boulevard Implementation committee
- Member of South Padre Island Zoning Commission for Cameron County
- Member of South Padre Island Zoning Board of Adjustments for Cameron County
- Former Public Works Director for the Town of South Padre Island
- Former Assistant Emergency Management Coordinator for Town of South Padre Island

Other Information (Civic Activities):

- Member of the Laguna Madre Water District Board of Directors
- Member of South Padre Island Chamber of Commerce Board of Directors
- Member of the Laguna Madre Education Foundation Board of Directors
- Secretary of the Laguna Madre Water District Board of Directors
- Treasurer of South Padre Island Chamber of Commerce Board of Directors
- Treasurer of Laguna Madre Education Foundation Board of Directors
- Member of Port Isabel Chamber of Commerce
- Member of Port Isabel Rotary Club
- Program Chairman for the Port Isabel Rotary Club
- Member of the National Society of Professional Engineers
- Member of the Texas Society of Professional Engineers
- Member of the American Public Works Association
- Member of the American Water Works Association
- Member of the International Code Council
- Certified Windstorm Engineer by Texas Department of Insurance



Town of South Padre Island – Boards and Commissions Questionnaire
 4601 Padre Blvd. Phone: 956.761.6456
 South Padre Island, TX 78597 Fax: 956.761.3888

APPLICANT INFORMATION

Last Name: Fudge First: Robert M.I.: A Date: 9/27/10
 Street Address: 200 West Atol Apartment/Unit #: 4
 City: South Padre Island State: Texas Zip: 78597
 Phone: 956-772-1305 E-mail Address: rfudge@rgv.rr.com
 Occupation (Place of Business): Fudge Consulting, PLLC Phone: 956-433-9001

Are you a citizen of the United States? Yes No

Have you ever been convicted of a felony? Yes No If yes, please explain _____

Have you ever been convicted of, received probation or deferred adjudication for any offense that was not a felony? Yes No If yes, please explain: Traffic Citation

Do you have a current Driver's License? Yes No

Have you been a resident of the Town of South Padre Island for at least six (6) months prior to the date of application? Yes No

If qualified, are you a registered South Padre Island voter? Yes No

Are you an adversary party to pending litigation against the Town of South Padre Island? Yes No If yes, please explain: _____

Are you an employee or a business associate of either an adversary party or a representative of an adversary party in any past or pending litigation against the Town of South Padre Island, other than an eminent domain proceeding? Yes No If yes, please explain: _____

Are you an employee or a business associate of either an adversary party or a representative of an adversary party that has a pecuniary interest in any past or pending litigation or claim against the Town of South Padre Island, other than an eminent domain proceeding? Yes No If yes, please explain: _____

Are you in arrears on any Town of South Padre Island taxes, water service charge or other obligations owned to the Town of South Padre Island? Yes No If yes, please explain: _____

Provide All Information Requested: INCOMPLETE APPLICATIONS WILL NOT BE CONSIDERED FOR BOARD/COMMISSION OPPORTUNITIES. Your complete application form will be maintained in our active files for six(6) months from the date of the application. I understand that should I not be appointed to the Town of South Padre Island board and commission, this application and any other records obtained, collected or otherwise prepared regarding this application shall be maintained in accordance with the Texas Public Information Act and the Town of South Padre Island's document retention schedule.

6-51

DISCLAIMER AND SIGNATURE

I certify that my answers are true and complete. I understand that the information contained in this application may be considered, among other criteria, qualifications and/or information, by the City Council in its evaluation for the position being sought. I further understand that should I be appointed to any Town of South Padre Island commission, I serve at the pleasure of the Town Board of Aldermen and may be removed from said position at any time and for any reason or no reason at all, with or without notice. I also understand that should I be appointed to a Town of South Padre Island Board or Commission, I must be responsible for a creditable record of attendance and performance. If this application leads to my appointment to a position on a Town of South Padre Island Board or Commission, I understand that false or misleading information in my application may result in my removal from the position.

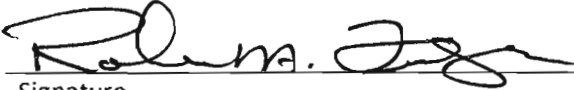

Signature

September 27, 2010

Date

6-57

Susan



City of South Padre Island – Committees, Boards and Commissions
Questionnaire
4601 Padre Blvd.
South Padre Island, TX 78597
Phone: 956/761-6456
Fax: 956/761-3888

APPLICANT INFORMATION

Last Name: HELMS First: JAMES M.I.: C Date: 9/27/10

Street Address: 115 EAST PALMETTO Apartment/Unit #:

City: SOUTH PADRE ISLAND State: TX Zip: 78597

Phone: 7611932 E-mail Address:

Occupation (Place of Business): RETIRED Phone:

Are you a citizen of the United States? Yes No

Have you ever been convicted of a felony? Yes No If yes, please explain:

Have you ever been convicted of, received probation or deferred adjudication for any offense that was not a felony? Yes No If yes, please explain:

Do you have a current Driver's License? Yes No

Have you been a resident of the City of South Padre Island for at least six (6) months prior to the date of application? Yes No

If qualified, are you a registered South Padre Island voter? Yes No

Are you an adversary party to pending litigation against the City of South Padre Island? Have you ever been an adversary part to litigation against the City of South Padre Island? Yes No If yes, please explain:

Are you an employee or a business associate of either an adversary party or a representative of an adversary party in any past or pending litigation against the City of South Padre Island, other than an eminent domain proceeding? Yes No If yes, please explain:

Are you an employee or a business associate of either an adversary party or a representative of an adversary party that has a pecuniary interest in any past or pending litigation or claim against the City of South Padre Island, other than an eminent domain proceeding? Yes No If yes, please explain:

Are you in arrears on any City of South Padre Island taxes, water service charge or other obligations owned to the City of South Padre Island? Yes No If yes, please explain:

Provide All Information Requested: INCOMPLETE APPLICATIONS WILL NOT BE CONSIDERED FOR COMMITTEE, BOARD OR COMMISSION OPPORTUNITIES. Your complete application form will be maintained in our active files for six (6) months from the date of the application. I understand that should I not be appointed to the City of South Padre Island committee, board or commission, this application and any other records obtained, collected or otherwise prepared regarding this application shall be maintained in accordance with the Texas Public Information Act and the City of South Padre Island's document retention schedule.

6-53

DISCLAIMER AND SIGNATURE

I certify that my answers are true and complete. I understand that the information contained in this application may be considered, among other criteria, qualifications and/or information, by the City Council in its evaluation for the position being sought. I further understand that should I be appointed to any City of South Padre Island committee, board, or commission, I serve at the pleasure of the South Padre Island City Council and may be removed from said position at any time and for any reason or no reason at all, with or without notice. I also understand that should I be appointed to a City of South Padre Island Board or Commission, I must be responsible for a creditable record of attendance and performance. If this application leads to my appointment to a position on a City of South Padre Island Committee, Board or Commission, I understand that false or misleading information in my application may result in my removal from the position.

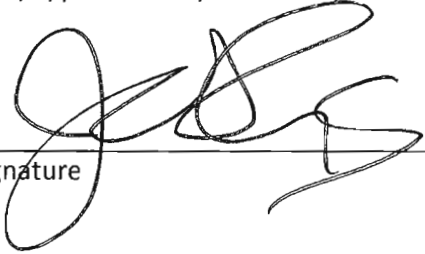

Signature

9/27/10

Date

Development Standards

**CANDIDATE APPLICATION FORM
FOR COUNCIL-APPOINTED BOARDS, COMMITTEES &
COMMISSIONS**

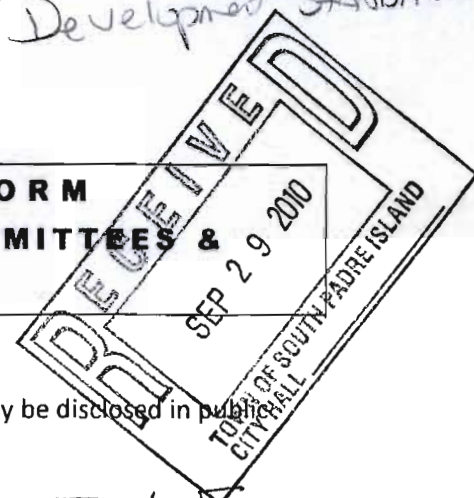

Information disclosed on this application or any other attached document may be disclosed in public meetings. Please print clearly.

Board Preference 1: Development Standards Review Task Force

Board Preference 2: Park or Any per City Council

Name: Jody Hughes

Home Address: PO Box 40141 5709 Gulf Blvd. SPI, TX

City: South Padre Island Zip: 78597 SPI Resident: 2 1/2 years

Home Telephone: 956-371-0711 Home Fax: 956-761-3369

Home E-Mail: jodyhughes1@yahoo.com

Profession: Executive Director POWC-SPI / Retired TRS

Business Name: POWC-SPI

Business Address: PO Box 2778

City: SPI State: TX Zip: 78597

Business Telephone: 956-371-0711

Business E-Mail: jodyhughes1@yahoo.com www.powc-spi.org

Special Knowledge or Experience applicable to City or Board/Commission Function:

Have served on DP RB for past 2 years.
Traveled extensively & have vision to work with.

Home Rule Charter Commission,

Other Information (Civic Activities): El Paseo Arts Foundation Board,

Chairman - Islanders SPI Chamber - SPI-chamber Gala
Committee

I verify that the information I have provided in this application to be true and correct. I also acknowledge that this information may be made available to the public.

Signature Jody Hughes

Date 9-21-2010

PLEASE RETURN COMPLETED APPLICATION TO THE CITY SECRETARY'S OFFICE, TOWN OF SOUTH PADRE ISLAND, 4601 PADRE BLVD., SOUTH PADRE ISLAND, TX 78597 OR FAX 956.761.3888.

6-55



Town of South Padre Island -- Boards and Commissions Questionnaire
 4601 Padre Blvd. Phone: 956.761.6456
 South Padre Island, TX 78597 Fax: 956.761.3888

APPLICANT INFORMATION

Last Name: Hughes First: Jody M.I.: P Date: 9-21-10
 Street Address: 5709 Gulf Blvd. Apartment/Unit #: PO Box 40141
 City: South Padre Island State: TX Zip: 78597
 Phone: 956-371-0711 E-mail Address: jodyhughes1@yahoo.com
 Occupation (Place of Business): Ex. Director - POWC Phone: 371-0711

Are you a citizen of the United States? Yes No

Have you ever been convicted of a felony? Yes No If yes, please explain _____

Have you ever been convicted of, received probation or deferred adjudication for any offense that was not a felony? Yes No If yes, please explain: _____

Do you have a current Driver's License? Yes No

Have you been a resident of the Town of South Padre Island for at least six (6) months prior to the date of application? Yes No

If qualified, are you a registered South Padre Island voter? Yes No

Are you an adversary party to pending litigation against the Town of South Padre Island? Yes No If yes, please explain: ? POWC - Not sure where that stands.

Are you an employee or a business associate of either an adversary party or a representative of an adversary party in any past or pending litigation against the Town of South Padre Island, other than an eminent domain proceeding? Yes No If yes, please explain: _____

Are you an employee or a business associate of either an adversary party or a representative of an adversary party that has a pecuniary interest in any past or pending litigation or claim against the Town of South Padre Island, other than an eminent domain proceeding? Yes No If yes, please explain: _____

Are you in arrears on any Town of South Padre Island taxes, water service charge or other obligations owned to the Town of South Padre Island? Yes No If yes, please explain: _____

Provide All Information Requested: INCOMPLETE APPLICATIONS WILL NOT BE CONSIDERED FOR BOARD/COMMISSION OPPORTUNITIES. Your complete application form will be maintained in our active files for six(6) months from the date of the application. I understand that should I not be appointed to the Town of South Padre Island board and commission, this application and any other records obtained, collected or otherwise prepared regarding this application shall be maintained in accordance with the Texas Public Information Act and the Town of South Padre island's document retention schedule.

DISCLAIMER AND SIGNATURE

I certify that my answers are true and complete. I understand that the information contained in this application may be considered, among other criteria, qualifications and/or information, by the City Council in its evaluation for the position being sought. I further understand that should I be appointed to any Town of South Padre Island commission, I serve at the pleasure of the Town Board of Aldermen and may be removed from said position at any time and for any reason or no reason at all, with or without notice. I also understand that should I be appointed to a Town of South Padre Island Board or Commission, I must be responsible for a creditable record of attendance and performance. If this application leads to my appointment to a position on a Town of South Padre Island Board or Commission, I understand that false or misleading information in my application may result in my removal from the position.

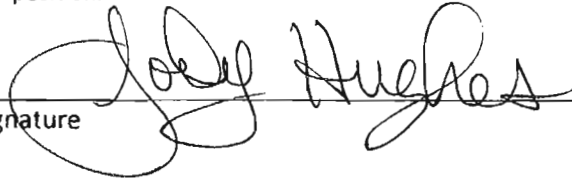
Signature 

Date 9-21-10

**Jody Perkes Hughes
PO Box 40141
5709 Gulf Blvd.
South Padre Island, TX 78597
956-371-0711 Cell
956-761-3369 Home/FAX**

Experience and Skills

I retired from Texas Education Agency with 30 years of experience in 2005. I taught seven years K-12th grade Special Education and General Education. I was an Educational Diagnostician for the last 23 years of my public education service. I also taught one year at Saint Joseph Academy in Brownsville, Texas 2005-2006 school year.

In July, 2008, I was hired by POWC-SPI to be their Executive Director upon moving back to South Padre Island.

Work History

- Executive Director for POWC-SPI (7-2008 to present)
- Teacher – Saint Joseph Academy (Catholic Middle-HS) Brownsville, TX (2005-06)
- Los Fresnos CISD - Educational Diagnostician – All levels – (2003-2005)
- Cypress Fairbanks ISD - Educational Diagnostician - Houston Texas, Waller ISD - Educational Diagnostician – Waller, Texas, Klein ISD - Educational Diagnostician-Spring, Texas, Aldine ISD - Educational Diagnostician, Teacher in Brownsville ISD, Brownsville, Texas, McAllen ISD McAllen, Pharr, San Juan, Alamo ISD Pharr, Texas (1973-2003)

- **Education and Training**

- Masters of Education, Educational Diagnostician
And Learning Disabilities Certification
Pan American University – Edinburg, TX UT-Edinburg 1973 to 1975
- Bachelors of Education (Cum Laude Graduate)
Elementary Education and English and History Minors
Pan American University – Edinburg, TX 1968 to 1972

Honors, Awards, and Community Service

Collegiate

Yearbook Editor & Co-Editor 1969 to 1972 at PAU
Graduate – Cum Laude 1972 BS in Education
Who's Who In American Colleges and Universities, 1972
Pan American University Cheerleader 1970 –1972

Professional

Certification – Texas Dept. of MHMRA – January 1982

South Padre Island Committees, Commissions and Boards

Development Plan and Review Board (DPRB) 9-08- 2010
Home Rule Charter Commission (HRRC) 12-08
Certified Retirement Community Board (CRRB) 10-08
Web Task Force 2010

Memberships

Member of SPI Chamber of Commerce since 2008
El Paseo Arts Foundation since 2008
Club Padre Member
SPIRIT
Birding and Nature Center

Community Service – Brownsville, TX 2003 to Present

Board of Directors – El Paseo Arts Foundation
Chairman of Islanders SPI Chamber of Commerce
Gala Committee SPI Chamber of Commerce
Leadership Laguna Madre Class XIV
Board of Directors Camille Playhouse, Brownsville, TX - 2004-2007
Performed in three musicals at Camille Playhouse and 4 plays for El Paseo Arts Foundation
Advisor to Lower Rio Grande Valley Cotillion – 2007
Advisor to South Texas Cotillion – 2008, 2009

Community Service – Houston, TX 1980 - 2003

Past President of Xi Delta Theta Chapter of Beta Sigma Phi, 1982-83 & 1991-92
Vice President of Houston City Council of Beta Sigma Phi 1990-91
Vice President of Children’s Special Events, Yeager Elementary 1993-94
Head Home Room, Yeager Elementary 1989 to 1995
5th Grade Liaison, Yeager Elementary 1995-96
Member & Officer of Cypress Creek Chapter of National Charity League 1995 to 2003
Member of Cypress Woodlands Junior Forum 1996 to 2003
Mother Daughter Most Philanthropy Hour Award – National Charity League 1998
Mother of Sugar Plum Cotillion Debutante 1997 to 2001
Secretary & Vice President of Choir Booster – Cypress Creek HS Choir 1998- 2001
Grade Level Advisor for 7th Grade for National Charity League 2002-2003
50 Hour Award for National Charity League – 2002-2003
National Charity League Mother Daughter Most Philanthropy Hour Award – 2003

Development STANDARDS

**CANDIDATE APPLICATION FORM
FOR COUNCIL-APPOINTED BOARDS, COMMITTEES &
COMMISSIONS**

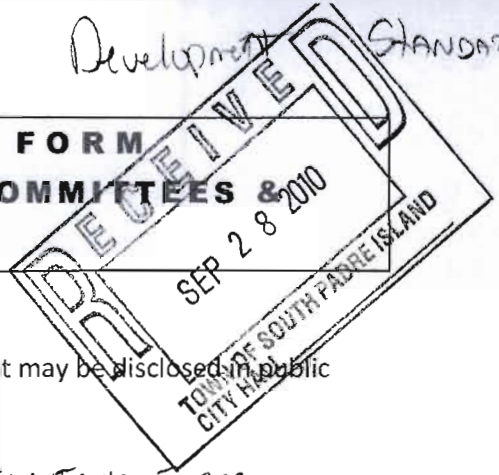

Information disclosed on this application or any other attached document may be disclosed in public meetings. Please print clearly.

Board Preference 1: DEVELOPMENT STANDARDS REVIEW TASK FORCE

Board Preference 2: ECONOMIC DEVELOPMENT CORPORATION

Name: George P. LESIEUTRE

Home Address: P.O. Box 3891 - 116 E. POLARIS #201

City: SOUTH PADRE ISLAND Zip: 78597 SPI Resident: 12 years

Home Telephone: 956 453 3436 Home Fax: _____

Home E-Mail: 13 PIERRE@SBCGLOBAL.NET

Profession: FINANCE - INSURANCE

Business Name: RETIRED

Business Address: _____

City: _____ State: _____ Zip: _____

Business Telephone: _____

Business E-Mail: _____

Special Knowledge or Experience applicable to City or Board/Commission Function: 2 YR BUSINESS

COLLEGES - 2 YRS ENGINEERING - ARM INSURANCE INSTITUTE, DIRECTOR OF CAPTIVE

INS. CO - ASST TO TREASURER CORPORATE, MFG PLANT CONTROLLER - INS BACKERS

LICENSE 10 YEARS STATE OF ILLINOIS. - PRESIDENT SEASCAPE CONDO OWNERS ASSOCIATION

Other Information (Civic Activities): VILLAGE OF STREAMWOOD, IL - VILLAGE TRUSTEE

AND ECONOMIC DEVELOPMENT COMMITTEE, IL U46 CITIZENS ADVISORY COMMITTEE

VICE CHAIRMAN AND OTHER COMM. PRESIDENT PTA, BSA COUNCIL COMM. - YOUTH TEACHING

CHURCH

I verify that the information I have provided in this application to be true and correct. I also acknowledge that this information may be made available to the public.

George P. Lesieutre
Signature

9/28/2010
Date

PLEASE RETURN COMPLETED APPLICATION TO THE CITY SECRETARY'S OFFICE, TOWN OF SOUTH PADRE ISLAND, 4601 PADRE BLVD., SOUTH PADRE ISLAND, TX 78597 OR FAX 956.761.3888.



Town of South Padre Island – Boards and Commissions Questionnaire
 4601 Padre Blvd. Phone: 956.761.6456
 South Padre Island, TX 78597 Fax: 956.761.3888

APPLICANT INFORMATION

Last Name: LESIEUTRE First: George M.I.: P Date: 9/28/2010
 Street Address: 116 E. POLARIS Apartment/Unit #: 201
 City: SOUTH PADRE ISLAND State: TX Zip: 78597
 Phone: 956 453 3436 E-mail Address: 13 PIERRE@SbcGLOBAL.NET
 Occupation (Place of Business): Retired Phone: NA

Are you a citizen of the United States? Yes No

Have you ever been convicted of a felony? Yes No If yes, please explain _____

Have you ever been convicted of, received probation or deferred adjudication for any offense that was not a felony? Yes No If yes, please explain: _____

Do you have a current Driver's License? Yes No

Have you been a resident of the Town of South Padre Island for at least six (6) months prior to the date of application? Yes No

If qualified, are you a registered South Padre Island voter? Yes No

Are you an adversary party to pending litigation against the Town of South Padre Island? Have you ever been an adversary part to litigation against the Town of South Padre Island? Yes No If yes, please explain: _____

Are you an employee or a business associate of either an adversary party or a representative of an adversary party in any past or pending litigation against the Town of South Padre Island, other than an eminent domain proceeding? Yes No If yes, please explain: _____

Are you an employee or a business associate of either an adversary party or a representative of an adversary party that has a pecuniary interest in any past or pending litigation or claim against the Town of South Padre Island, other than an eminent domain proceeding? Yes No If yes, please explain: _____

Are you in arrears on any Town of South Padre Island taxes, water service charge or other obligations owned to the Town of South Padre Island? Yes No If yes, please explain: _____

Provide All Information Requested: INCOMPLETE APPLICATIONS WILL NOT BE CONSIDERED FOR BOARD/COMMISSION OPPORTUNITIES. Your complete application form will be maintained in our active files for six(6) months from the date of the application. I understand that should I not be appointed to the Town of South Padre Island board and commission, this application and any other records obtained, collected or otherwise prepared regarding this application shall be maintained in accordance with the Texas Public Information Act and the Town of South Padre island's document retention schedule.

DISCLAIMER AND SIGNATURE

I certify that my answers are true and complete. I understand that the information contained in this application may be considered, among other criteria, qualifications and/or information, by the City Council in its evaluation for the position being sought. I further understand that should I be appointed to any Town of South Padre Island commission, I serve at the pleasure of the Town Board of Aldermen and may be removed from said position at any time and for any reason or no reason at all, with or without notice. I also understand that should I be appointed to a Town of South Padre Island Board or Commission, I must be responsible for a creditable record of attendance and performance. If this application leads to my appointment to a position on a Town of South Padre Island Board or Commission, I understand that false or misleading information in my application may result in my removal from the position.

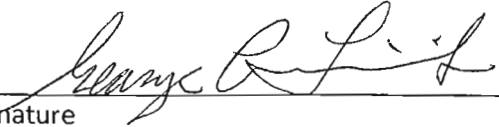

Signature
George P. LESIEUR

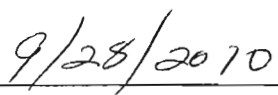

Date

**CANDIDATE APPLICATION FORM
FOR COUNCIL-APPOINTED BOARDS, COMMITTEES &
COMMISSIONS**

Information disclosed on this application or any other attached document may be disclosed in public meetings. Please print clearly.

Board Preference 1: DEVELOPMENT STANDARDS REVIEW TASK FORCE

Board Preference 2: _____

Name: Nancy M. Moyer

Home Address: 200 W. Sheephead St

City: SPI Zip: 78597 SPI Resident: 10 years

Home Telephone: 761-6710 Home Fax: _____

Home E-Mail: bnmoyer@sbcglobal.net

Profession: RETIRED (COURT REPORTER)

Business Name: _____

Business Address: _____

City: _____ State: _____

Business Telephone: _____

Business E-Mail: _____

Special Knowledge or Experience applicable to City or Board/Commission Function: _____

(DPRB) PADRE ISLAND REVITALIZATION COMMITTEE (and its
2 TERMS) brief successor)

EXTENSIVE TRAVEL TO CITIES IN US + ABROAD.

Other Information (Civic Activities): ex El Paso Arts Board member, Coal
City Committee

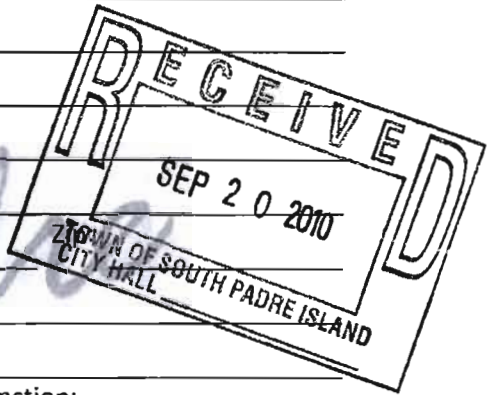

I verify that the information I have provided in this application to be true and correct. I also acknowledge that this information may be made available to the public.

Signature Nancy M. Moyer

Date Sept 17, 2010

PLEASE RETURN COMPLETED APPLICATION TO THE CITY SECRETARY'S OFFICE, TOWN OF SOUTH PADRE ISLAND, 4601 PADRE BLVD., SOUTH PADRE ISLAND, TX 78597 OR FAX 956.761.3888.



Town of South Padre Island – Boards and Commissions Questionnaire

4601 Padre Blvd.
South Padre Island, TX 78597

Phone: 956.761.6456

Fax: 956.761.3888

APPLICANT INFORMATION

Last Name: MOYER First: NAUCY M.I.: M Date: 10/17/10

Street Address: 200 W. Sheephead ST Apartment/Unit #:

City: SPI State: TX Zip: 78597

Phone: 761-6710 E-mail Address: BNMOYER@56CGLOBAL.NET

Occupation (Place of Business): RETIRED Phone: _____

Are you a citizen of the United States? Yes No

Have you ever been convicted of a felony? Yes No If yes, please explain _____

Have you ever been convicted of, received probation or deferred adjudication for any offense that was not a felony? Yes No If yes, please explain: _____

Do you have a current Driver's License? Yes No

Have you been a resident of the Town of South Padre Island for at least six (6) months prior to the date of application? Yes No

If qualified, are you a registered South Padre Island voter? Yes No

Are you an adversary party to pending litigation against the Town of South Padre Island? Have you ever been an adversary part to litigation against the Town of South Padre Island? Yes No If yes, please explain: _____

Are you an employee or a business associate of either an adversary party or a representative of an adversary party in any past or pending litigation against the Town of South Padre Island, other than an eminent domain proceeding? Yes No If yes, please explain: _____

Are you an employee or a business associate of either an adversary party or a representative of an adversary party that has a pecuniary interest in any past or pending litigation or claim against the Town of South Padre Island, other than an eminent domain proceeding? Yes No If yes, please explain: _____

Are you in arrears on any Town of South Padre Island taxes, water service charge or other obligations owned to the Town of South Padre Island? Yes No If yes, please explain: _____

Provide All Information Requested: INCOMPLETE APPLICATIONS WILL NOT BE CONSIDERED FOR BOARD/COMMISSION OPPORTUNITIES. Your complete application form will be maintained in our active files for six(6) months from the date of the application. I understand that should I not be appointed to the Town of South Padre Island board and commission, this application and any other records obtained, collected or otherwise prepared regarding this application shall be maintained in accordance with the Texas Public Information Act and the Town of South Padre island's document retention schedule.

DISCLAIMER AND SIGNATURE

I certify that my answers are true and complete. I understand that the information contained in this application may be considered, among other criteria, qualifications and/or information, by the City Council in its evaluation for the position being sought. I further understand that should I be appointed to any Town of South Padre Island commission, I serve at the pleasure of the Town Board of Aldermen and may be removed from said position at any time and for any reason or no reason at all, with or without notice. I also understand that should I be appointed to a Town of South Padre island Board or Commission, I must be responsible for a creditable record of attendance and performance. If this application leads to my appointment to a position on a Town of South Padre Island Board or Commission, I understand that false or misleading information in my application may result in my removal from the position.

Nancy M. Moyer
Signature

Sept 17, 2010
Date

**CANDIDATE APPLICATION FORM
FOR COUNCIL-APPOINTED BOARDS, COMMITTEES &
COMMISSIONS**

Information disclosed on this application or any other attached document may be disclosed in public meetings. Please print clearly.

Board Preference 1: Form Based Code / Development Stamp
Board Preference 2: Review

Name: Steve O'Neal

Home Address: 232 West Hibiscus St SPI TX

City: SPI Zip: 78597 SPI Resident: 6 years

Home Telephone: 956-761-1231 Home Fax: _____

Home E-Mail: O'Neal Steve P Sbcglobal.net

Profession: Contractor / Developer

Business Name: BayScape Developer / Ridgeway Developers

Business Address: P.O. Box 3404

City: SPI State: TX Zip: 78597

Business Telephone: _____

Business E-Mail: Same as above

Special Knowledge or Experience applicable to City or Board/Commission Function: Past Bay Area Tr

force, Comprehensive Planning Committee, S.PI Community Inc
Past Form Based Code, Planning & Zoning Commis
Past Logan County FEDC - V.P., Past Director Logan Co. Chamber
of Commerce

Other Information (Civic Activities): _____

I verify that the information I have provided in this application to be true and correct. I also acknowledge that this information may be made available to the public.

Stephen B O'Neal
Signature

9-29-10
Date

PLEASE RETURN COMPLETED APPLICATION TO THE CITY SECRETARY'S OFFICE, TOWN OF SOUTH PADRE ISLAND, 4601 PADRE BLVD., SOUTH PADRE ISLAND, TX 78597 OR FAX 956.761.3888.

b-66



Town of South Padre Island - Boards and Commissions Questionnaire
4601 Padre Blvd.
South Padre Island, TX 78597
Phone: 956.761.6456
Fax: 956.761.3888

APPLICANT INFORMATION

Last Name: O'NEAL First: Steve M.I.: E Date: 9-28-10
Street Address: 232 W. Hibiscus St. Apartment/Unit #:
City: SPI State: TX Zip: 78597
Phone: 956-761-1231 F-mail Address:
(C) 970-391-9003
Occupation (Place of Business): Bay Scope Developers Phone: 761-1231

Are you a citizen of the United States? Yes [X] No []

Have you ever been convicted of a felony? Yes [] No [X] If yes, please explain

Have you ever been convicted of, received probation or deferred adjudication for any offense that was not a felony? Yes [] No [X] If yes, please explain

Do you have a current Driver's License? Yes [X] No []

Have you been a resident of the Town of South Padre Island for at least six (6) months prior to the date of application? Yes [X] No []

If qualified, are you a registered South Padre Island voter? Yes [X] No []

Are you an adversary party to pending litigation against the Town of South Padre Island? Have you ever been an adversary part to litigation against the Town of South Padre Island? Yes [] No [X] If yes, please explain:

Are you an employee or a business associate of either an adversary party or a representative of an adversary party in any past or pending litigation against the Town of South Padre Island, other than an eminent domain proceeding? Yes [] No [X] If yes, please explain:

Are you an employee or a business associate of either an adversary party or a representative of an adversary party that has a pecuniary interest in any past or pending litigation or claim against the Town of South Padre Island, other than an eminent domain proceeding? Yes [] No [X] If yes, please explain:

Are you in arrears on any Town of South Padre Island taxes, water service charge or other obligations owned to the Town of South Padre Island? Yes [] No [X] If yes, please explain:

Provide All Information Requested: INCOMPLETE APPLICATIONS WILL NOT BE CONSIDERED FOR BOARD/COMMISSION OPPORTUNITIES. Your complete application form will be maintained in our active files for six(6) months from the date of the application. I understand that should I not be appointed to the Town of South Padre Island board and commission, this application and any other records obtained, collected or otherwise prepared regarding this application shall be maintained in accordance with the Texas Public Information Act and the Town of South Padre island's document retention schedule.

6-67

DISCLAIMER AND SIGNATURE

I certify that my answers are true and complete. I understand that the information contained in this application may be considered, among other criteria, qualifications and/or information, by the City Council in its evaluation for the position being sought. I further understand that should I be appointed to any Town of South Padre Island commission, I serve at the pleasure of the Town Board of Aldermen and may be removed from said position at any time and for any reason or no reason at all, with or without notice. I also understand that should I be appointed to a Town of South Padre Island Board or Commission, I must be responsible for a creditable record of attendance and performance. If this application leads to my appointment to a position on a Town of South Padre Island Board or Commission, I understand that false or misleading information in my application may result in my removal from the position.

Stephen R. Oinas
Signature

9-28-10
Date

6-68

*Economic Development Corporation
Board of Directors*

3 Positions expiring (for City Council appointment)

Incumbents requesting another term:

- Richard Franke

New Applications:

- George Lesieutre

**CANDIDATE APPLICATION FORM
FOR COUNCIL-APPOINTED BOARDS, COMMITTEES &
COMMISSIONS**

Information disclosed on this application or any other attached document may be disclosed in public meetings. Please print clearly.

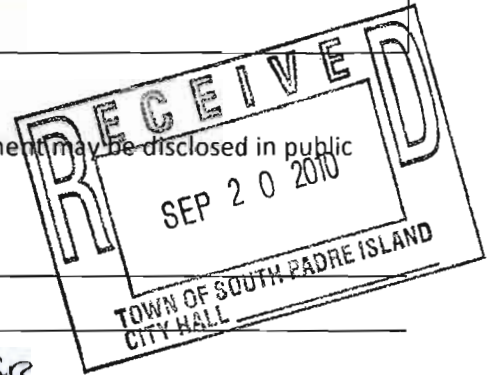

Board Preference 1: EDC

Board Preference 2: _____

Name: RICHARD FRANKS SR

Home Address: 8605 ~~PADRE~~ ^{MARGINA} BLVD. DR

City: SPI Zip: 78597 SPI Resident: 30+ years

Home Telephone: _____ Home Fax: _____

Home E-Mail: _____

Profession: REAL ESTATE

Business Name: FRANKS INC

Business Address: 8605 PADRE

City: SPI State: _____ Zip: _____

Business Telephone: 956 761 2100

Business E-Mail: RICHARDSR@FRANKSPOSTERS.COM

Special Knowledge or Experience applicable to City or Board/Commission Function:

MANY YEARS OF SERVICE ON EDC & CVB

Other Information (Civic Activities): VIA AIRPORT BOARD

I verify that the information I have provided in this application to be true and correct. I also acknowledge that this information may be made available to the public.

Signature: [Handwritten Signature] Date: 9/17/10

PLEASE RETURN COMPLETED APPLICATION TO THE CITY SECRETARY'S OFFICE, TOWN OF SOUTH PADRE ISLAND, 4601 PADRE BLVD., SOUTH PADRE ISLAND, TX 78597 OR FAX 956.761.3888.

6-70



Town of South Padre Island – Boards and Commissions Questionnaire
 4601 Padre Blvd. Phone: 956.761.6456
 South Padre Island, TX 78597 Fax: 956.761.3888

APPLICANT INFORMATION

Last Name: FRANKE First: RICHARD SR M.I.: J. Date: 9/17/10
 Street Address: 8605 PADRE BLVD Apartment/Unit #: _____
 City: SPI State: TX Zip: 78597
 Phone: 761-2606 E-mail Address: RICHARD SR @ FRANKERATORS.COM
 Occupation (Place of Business): FRANKE INC. Phone: _____
 Are you a citizen of the United States? Yes No
 Have you ever been convicted of a felony? Yes No If yes, please explain _____
 Have you ever been convicted of, received probation or deferred adjudication for any offense that was not a felony? Yes No If yes, please explain: _____
 Do you have a current Driver's License? Yes No
 Have you been a resident of the Town of South Padre Island for at least six (6) months prior to the date of application? Yes No
 If qualified, are you a registered South Padre Island voter? Yes No
 Are you an adversary party to pending litigation against the Town of South Padre Island? Have you ever been an adversary part to litigation against the Town of South Padre Island? Yes No If yes, please explain: _____
 Are you an employee or a business associate of either an adversary party or a representative of an adversary party in any past or pending litigation against the Town of South Padre Island, other than an eminent domain proceeding? Yes No If yes, please explain: _____
 Are you an employee or a business associate of either an adversary party or a representative of an adversary party that has a pecuniary interest in any past or pending litigation or claim against the Town of South Padre Island, other than an eminent domain proceeding? Yes No If yes, please explain: _____
 Are you in arrears on any Town of South Padre Island taxes, water service charge or other obligations owned to the Town of South Padre Island? Yes No If yes, please explain: _____

Provide All Information Requested: INCOMPLETE APPLICATIONS WILL NOT BE CONSIDERED FOR BOARD/COMMISSION OPPORTUNITIES. Your complete application form will be maintained in our active files for six(6) months from the date of the application. I understand that should I not be appointed to the Town of South Padre Island board and commission, this application and any other records obtained, collected or otherwise prepared regarding this application shall be maintained in accordance with the Texas Public Information Act and the Town of South Padre island's document retention schedule.

6-71

DISCLAIMER AND SIGNATURE

I certify that my answers are true and complete. I understand that the information contained in this application may be considered, among other criteria, qualifications and/or information, by the City Council in its evaluation for the position being sought. I further understand that should I be appointed to any Town of South Padre Island commission, I serve at the pleasure of the Town Board of Aldermen and may be removed from said position at any time and for any reason or no reason at all, with or without notice. I also understand that should I be appointed to a Town of South Padre island Board or Commission, I must be responsible for a creditable record of attendance and performance. If this application leads to my appointment to a position on a Town of South Padre Island Board or Commission, I understand that false or misleading information in my application may result in my removal from the position

Signature

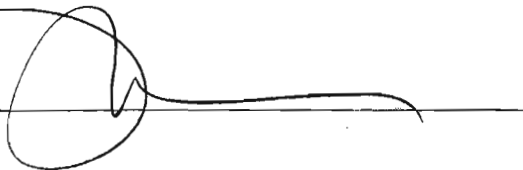
A handwritten signature in black ink, consisting of a large, stylized loop followed by a horizontal line extending to the right.

Date

9/17/10

6-72

EDC

**CANDIDATE APPLICATION FORM
FOR COUNCIL-APPOINTED BOARDS, COMMITTEES &
COMMISSIONS**



Information disclosed on this application or any other attached document may be disclosed in public meetings. Please print clearly.

Board Preference 1: DEVELOPMENT STANDARDS REVIEW TASK FORCE

Board Preference 2: ECONOMIC DEVELOPMENT CORPORATION

Name: George P. LESIEUTRE

Home Address: P.O. Box 3891 - 116 E. POLARIS #201

City: SOUTH PADRE ISLAND Zip: 78597 SPI Resident: 12 years

Home Telephone: 956 453 3436 Home Fax: _____

Home E-Mail: 13 PIERRE@SBCGLOBAL.NET

Profession: FINANCE - INSURANCE

Business Name: RETIRED

Business Address: _____

City: _____ State: _____ Zip: _____

Business Telephone: _____

Business E-Mail: _____

Special Knowledge or Experience applicable to City or Board/Commission Function: 2 YR BUSINESS

COLLEGES - 2 YRS ENGINEERING - AIA INSURANCE INSTITUTE, DIRECTOR OF CAPTIVE

INS. CO - ASST TO TREASURER CORPORATE, MFG PLANT CONTROLLER - INS BROKERS

LICENSE 10 YEARS STATE OF ILLINOIS - PRESIDENT SEASCAPE CONDO OWNERS ASSOCIATION

Other Information (Civic Activities): VILLAGE OF STREAMWOOD, IL - VILLAGE TRUSTEE

AND ECONOMIC DEVELOPMENT COMMITTEE, IL U46 CITIZENS ADVISORY COMMITTEE

VICE CHAIRMAN AND OTHER COMM. PRESIDENT PTA, BSA COUNCIL COMM. - YOUTH TEACHING

I verify that the information I have provided in this application to be true and correct. I also acknowledge that this information may be made available to the public.

George P. Lesieutre
Signature

9/28/2010
Date

PLEASE RETURN COMPLETED APPLICATION TO THE CITY SECRETARY'S OFFICE, TOWN OF SOUTH PADRE ISLAND, 4601 PADRE BLVD., SOUTH PADRE ISLAND, TX 78597 OR FAX 956.761.3888.

6-73



Town of South Padre Island – Boards and Commissions Questionnaire
 4601 Padre Blvd. Phone: 956.761.6456
 South Padre Island, TX 78597 Fax: 956.761.3888

APPLICANT INFORMATION

Last Name: LESIEUTRE First: George M.I.: P Date: 9/28/2010
 Street Address: 116 E. BLAIRS Apartment/Unit #: 201
 City: South Padre Island State: TX Zip: 78597
 Phone: 956 453 3436 E-mail Address: 13 PIERRE@SbcGLOBAL.NET
 Occupation (Place of Business): Retired Phone: NA

Are you a citizen of the United States? Yes No

Have you ever been convicted of a felony? Yes No If yes, please explain _____

Have you ever been convicted of, received probation or deferred adjudication for any offense that was not a felony? Yes No If yes, please explain: _____

Do you have a current Driver's License? Yes No

Have you been a resident of the Town of South Padre Island for at least six (6) months prior to the date of application? Yes No

If qualified, are you a registered South Padre Island voter? Yes No

Are you an adversary party to pending litigation against the Town of South Padre Island? Have you ever been an adversary part to litigation against the Town of South Padre Island? Yes No If yes, please explain: _____

Are you an employee or a business associate of either an adversary party or a representative of an adversary party in any past or pending litigation against the Town of South Padre Island, other than an eminent domain proceeding? Yes No If yes, please explain: _____

Are you an employee or a business associate of either an adversary party or a representative of an adversary party that has a pecuniary interest in any past or pending litigation or claim against the Town of South Padre Island, other than an eminent domain proceeding? Yes No If yes, please explain: _____

Are you in arrears on any Town of South Padre Island taxes, water service charge or other obligations owned to the Town of South Padre Island? Yes No If yes, please explain: _____

Provide All Information Requested: INCOMPLETE APPLICATIONS WILL NOT BE CONSIDERED FOR BOARD/COMMISSION OPPORTUNITIES. Your complete application form will be maintained in our active files for six(6) months from the date of the application. I understand that should I not be appointed to the Town of South Padre Island board and commission, this application and any other records obtained, collected or otherwise prepared regarding this application shall be maintained in accordance with the Texas Public Information Act and the Town of South Padre island's document retention schedule.

6-74

DISCLAIMER AND SIGNATURE

I certify that my answers are true and complete. I understand that the information contained in this application may be considered, among other criteria, qualifications and/or information, by the City Council in its evaluation for the position being sought. I further understand that should I be appointed to any Town of South Padre Island commission, I serve at the pleasure of the Town Board of Aldermen and may be removed from said position at any time and for any reason or no reason at all, with or without notice. I also understand that should I be appointed to a Town of South Padre Island Board or Commission, I must be responsible for a creditable record of attendance and performance. If this application leads to my appointment to a position on a Town of South Padre Island Board or Commission, I understand that false or misleading information in my application may result in my removal from the position.

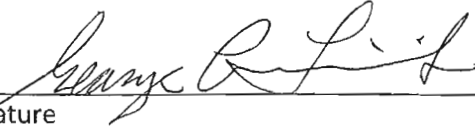

Signature
George P. LESIEUR

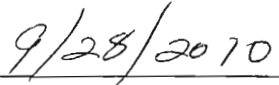

Date

6-75

Keep SPI Beautiful Committee

3 Positions expiring

Incumbents requesting another term: None

New Applications: None

Parks, Recreation & Beautification Committee

7 New Positions

New Applications:

- Jacky Conrad
- Jody Hughes

Parks + Rec

**CANDIDATE APPLICATION FORM
FOR COUNCIL-APPOINTED BOARDS, COMMITTEES &
COMMISSIONS**

Information disclosed on this application or any other attached document may be disclosed in public meetings. Please print clearly.

Board Preference 1: Parks + Recreation

Board Preference 2: CVA

Name: Jacky Conrad

Home Address: 218 W. Esperanza

City: SPI, TX Zip: 78597 SPI Resident: 5 years

Home Telephone: 956-772-1974 Home Fax: 210-568-4127

Home E-Mail: jacky at jam @ aol.com

Profession: Headhunter

Business Name: Ja M Recruiting

Business Address: 218 W. Esperanza

City: SPI State: TX Zip: 78597

Business Telephone: 956-772-1974

Business E-Mail: jacky@jamrecruiting.com

Special Knowledge or Experience applicable to City or Board/Commission Function:

I have worked on many community events for SPI. I have been the lead on Jolly Days, 4th of July Parade, Christmas Parade, Breakfast with Santa
Other Information (Civic Activities): SPI Business Coalition member, assisted in more
Vice President of Laguna Madre Humane Society, SPI Business commu
Website Technology Committee, EDC Search Committee for BNC manage

I verify that the information I have provided in this application to be true and correct. I also acknowledge that this information may be made available to the public.

Jacky Conrad
Signature

9-29-2010
Date

PLEASE RETURN COMPLETED APPLICATION TO THE CITY SECRETARY'S OFFICE, TOWN OF SOUTH PADRE ISLAND, 4601 PADRE BLVD., SOUTH PADRE ISLAND, TX 78597 OR FAX 956.761.3888.

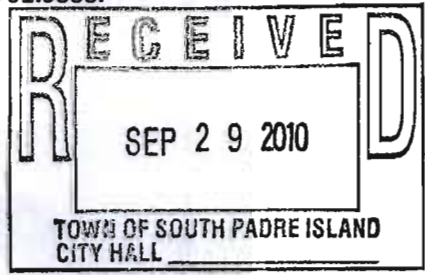

78



Town of South Padre Island – Boards and Commissions Questionnaire
 4601 Padre Blvd. Phone: 956.761.6456
 South Padre Island, TX 78597 Fax: 956.761.3888

APPLICANT INFORMATION

Last Name: Conrad First: Jacky M.I.: K Date: 9-29-2010
 Street Address: 218 W. Esperanza Apartment/Unit #: _____
 City: SPI State: TX Zip: 78597
 Phone: 956-772-1974 E-mail Address: jacky at jam@aol.com
 Occupation (Place of Business): Headhunter Phone: 956-772-1974

Are you a citizen of the United States? Yes No

Have you ever been convicted of a felony? Yes No If yes, please explain _____

Have you ever been convicted of, received probation or deferred adjudication for any offense that was not a felony? Yes If yes, please explain: _____
 No

Do you have a current Driver's License? Yes No

Have you been a resident of the Town of South Padre Island for at least six (6) months prior to the date of application? Yes No

If qualified, are you a registered South Padre Island voter? Yes No

Are you an adversary party to pending litigation against the Town of South Padre Island? Yes If yes, please explain: _____
 No

Are you an employee or a business associate of either an adversary party or a representative of an adversary party in any past or pending litigation against the Town of South Padre Island, other than an eminent domain proceeding? Yes If yes, please explain: _____
 No

Are you an employee or a business associate of either an adversary party or a representative of an adversary party that has a pecuniary interest in any past or pending litigation or claim against the Town of South Padre Island, other than an eminent domain proceeding? Yes If yes, please explain: _____
 No

Are you in arrears on any Town of South Padre Island taxes, water service charge or other obligations owned to the Town of South Padre Island? Yes If yes, please explain: _____
 No

Provide All Information Requested: INCOMPLETE APPLICATIONS WILL NOT BE CONSIDERED FOR BOARD/COMMISSION OPPORTUNITIES. Your complete application form will be maintained in our active files for six(6) months from the date of the application. I understand that should I not be appointed to the Town of South Padre Island board and commission, this application and any other records obtained, collected or otherwise prepared regarding this application shall be maintained in accordance with the Texas Public Information Act and the Town of South Padre island's document retention schedule.

6-79

DISCLAIMER AND SIGNATURE

I certify that my answers are true and complete. I understand that the information contained in this application may be considered, among other criteria, qualifications and/or information, by the City Council in its evaluation for the position being sought. I further understand that should I be appointed to any Town of South Padre Island commission, I serve at the pleasure of the Town Board of Aldermen and may be removed from said position at any time and for any reason or no reason at all, with or without notice. I also understand that should I be appointed to a Town of South Padre Island Board or Commission, I must be responsible for a creditable record of attendance and performance. If this application leads to my appointment to a position on a Town of South Padre Island Board or Commission, I understand that false or misleading information in my application may result in my removal from the position.

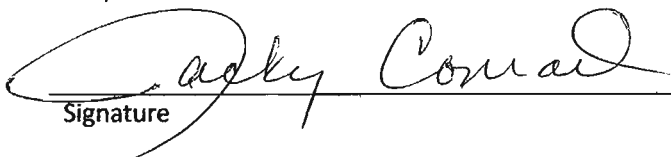
Signature

9-29-2010
Date

6-80

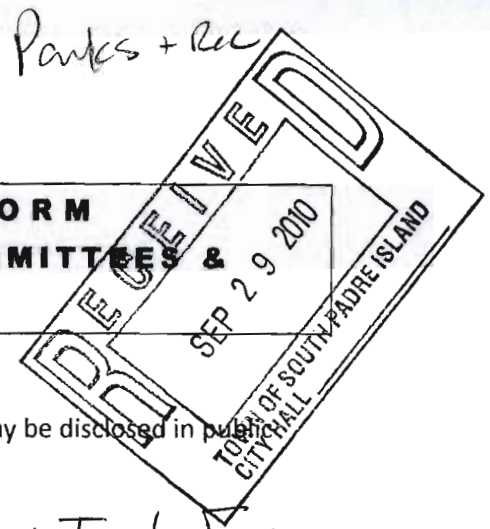

**CANDIDATE APPLICATION FORM
FOR COUNCIL-APPOINTED BOARDS, COMMITTEES &
COMMISSIONS**

Information disclosed on this application or any other attached document may be disclosed in public meetings. Please print clearly.

Board Preference 1: Development Standards Review Task Force

Board Preference 2: Park or Any per City Council

Name: Jody Hughes

Home Address: Po Box 40141 5709 Gulf Blvd. SPI, TX

City: South Padre Island Zip: 78597 SPI Resident: 2 1/2 years

Home Telephone: 956-371-0711 Home Fax: 956-761-3369

Home E-Mail: jodyhughes1@yahoo.com

Profession: Executive Director POWC-SPI / Retired TRS

Business Name: POWC-SPI

Business Address: Po Box 2778

City: SPI State: TX Zip: 78597

Business Telephone: 956-371-0711

Business E-Mail: Jodyhughes1@yahoo.com www.powc-spi.org

Special Knowledge or Experience applicable to City or Board/Commission Function:

Have served on DPRB for past 2 years.
Traveled extensively & have vision to work with.
Home Rule Charter Commission,
Other Information (Civic Activities): El Paseo Arts Foundation Board,
Chairman-Islanders SPI Chamber- SPI-chamber Gala
Committee

I verify that the information I have provided in this application to be true and correct. I also acknowledge that this information may be made available to the public.

Signature: Jody Hughes

Date: 9-21-2010

PLEASE RETURN COMPLETED APPLICATION TO THE CITY SECRETARY'S OFFICE, TOWN OF SOUTH PADRE ISLAND, 4601 PADRE BLVD., SOUTH PADRE ISLAND, TX 78597 OR FAX 956.761.3888.

6-81



Town of South Padre Island – Boards and Commissions Questionnaire

4601 Padre Blvd.

Phone: 956.761.6456

South Padre Island, TX 78597

Fax: 956.761.3888

APPLICANT INFORMATION

Last Name: Hughes First: Jody M.I.: P Date: 9-21-10
Street Address: 5709 Gulf Blvd. Apartment/Unit #: PO Box 40141
City: South Padre Island State: TX Zip: 78597
Phone: 956-371-0711 E-mail Address: jodyhughes1@yahoo.com
Occupation (Place of Business): Ex. Director - POWC Phone: 371-0711

Are you a citizen of the United States? Yes [checked] No []

Have you ever been convicted of a felony? Yes [] No [checked] If yes, please explain

Have you ever been convicted of, received probation or deferred adjudication for any offense that was not a felony? Yes [] No [checked] If yes, please explain:

Do you have a current Driver's License? Yes [checked] No []

Have you been a resident of the Town of South Padre Island for at least six (6) months prior to the date of application? Yes [checked] No []

If qualified, are you a registered South Padre Island voter? Yes [checked] No []

Are you an adversary party to pending litigation against the Town of South Padre Island? Have you ever been an adversary part to litigation against the Town of South Padre Island? Yes [] No [checked] If yes, please explain: ? POWC - Not sure where that stands.

Are you an employee or a business associate of either an adversary party or a representative of an adversary party in any past or pending litigation against the Town of South Padre Island, other than an eminent domain proceeding? Yes [] No [checked] If yes, please explain:

Are you an employee or a business associate of either an adversary party or a representative of an adversary party that has a pecuniary interest in any past or pending litigation or claim against the Town of South Padre Island, other than an eminent domain proceeding? Yes [] No [checked] If yes, please explain:

Are you in arrears on any Town of South Padre Island taxes, water service charge or other obligations owned to the Town of South Padre Island? Yes [] No [checked] If yes, please explain:

Provide All Information Requested: INCOMPLETE APPLICATIONS WILL NOT BE CONSIDERED FOR BOARD/COMMISSION OPPORTUNITIES. Your complete application form will be maintained in our active files for six(6) months from the date of the application. I understand that should I not be appointed to the Town of South Padre Island board and commission, this application and any other records obtained, collected or otherwise prepared regarding this application shall be maintained in accordance with the Texas Public Information Act and the Town of South Padre island's document retention schedule.

6-82

DISCLAIMER AND SIGNATURE

I certify that my answers are true and complete. I understand that the information contained in this application may be considered, among other criteria, qualifications and/or information, by the City Council in its evaluation for the position being sought. I further understand that should I be appointed to any Town of South Padre Island commission, I serve at the pleasure of the Town Board of Aldermen and may be removed from said position at any time and for any reason or no reason at all, with or without notice. I also understand that should I be appointed to a Town of South Padre Island Board or Commission, I must be responsible for a creditable record of attendance and performance. If this application leads to my appointment to a position on a Town of South Padre Island Board or Commission, I understand that false or misleading information in my application may result in my removal from the position.

Signature Joey Hughes

Date 9-21-10

b-83

**Jody Perkes Hughes
PO Box 40141
5709 Gulf Blvd.
South Padre Island, TX 78597
956-371-0711 Cell
956-761-3369 Home/FAX**

Experience and Skills

I retired from Texas Education Agency with 30 years of experience in 2005. I taught seven years K-12th grade Special Education and General Education. I was an Educational Diagnostician for the last 23 years of my public education service. I also taught one year at Saint Joseph Academy in Brownsville, Texas 2005-2006 school year.

In July, 2008, I was hired by POWC-SPI to be their Executive Director upon moving back to South Padre Island.

Work History

- Executive Director for POWC-SPI (7-2008 to present)
- Teacher – Saint Joseph Academy (Catholic Middle-HS) Brownsville, TX (2005-06)
- Los Fresnos CISD - Educational Diagnostician – All levels – (2003-2005)
- Cypress Fairbanks ISD - Educational Diagnostician - Houston Texas, Waller ISD - Educational Diagnostician – Waller, Texas, Klein ISD - Educational Diagnostician-Spring, Texas, Aldine ISD - Educational Diagnostician, Teacher in Brownsville ISD, Brownsville, Texas, McAllen ISD McAllen, Pharr, San Juan, Alamo ISD Pharr, Texas (1973-2003)

- **Education and Training**

- Masters of Education, Educational Diagnostician
And Learning Disabilities Certification
Pan American University – Edinburg, TX UT-Edinburg 1973 to 1975
- Bachelors of Education (Cum Laude Graduate)
Elementary Education and English and History Minors
Pan American University – Edinburg, TX 1968 to 1972

Honors, Awards, and Community Service

Collegiate

Yearbook Editor & Co-Editor 1969 to 1972 at PAU
Graduate – Cum Laude 1972 BS in Education
Who's Who In American Colleges and Universities, 1972
Pan American University Cheerleader 1970 –1972

Professional

Certification – Texas Dept. of MHMRA – January 1982

South Padre Island Committees, Commissions and Boards

Development Plan and Review Board (DPRB) 9-08- 2010
Home Rule Charter Commission (HRRC) 12-08
Certified Retirement Community Board (CRRB) 10-08
Web Task Force 2010

Memberships

Member of SPI Chamber of Commerce since 2008
El Paseo Arts Foundation since 2008
Club Padre Member
SPIRIT
Birding and Nature Center

Community Service – Brownsville, TX 2003 to Present

Board of Directors – El Paseo Arts Foundation
Chairman of Islanders SPI Chamber of Commerce
Gala Committee SPI Chamber of Commerce
Leadership Laguna Madre Class XIV
Board of Directors Camille Playhouse, Brownsville, TX - 2004-2007
Performed in three musicals at Camille Playhouse and 4 plays for El Paseo Arts Foundation
Advisor to Lower Rio Grande Valley Cotillion – 2007
Advisor to South Texas Cotillion – 2008, 2009

Community Service – Houston, TX 1980 - 2003

Past President of Xi Delta Theta Chapter of Beta Sigma Phi, 1982-83 & 1991-92
Vice President of Houston City Council of Beta Sigma Phi 1990-91
Vice President of Children’s Special Events, Yeager Elementary 1993-94
Head Home Room, Yeager Elementary 1989 to 1995
5th Grade Liaison, Yeager Elementary 1995-96
Member & Officer of Cypress Creek Chapter of National Charity League 1995 to 2003
Member of Cypress Woodlands Junior Forum 1996 to 2003
Mother Daughter Most Philanthropy Hour Award – National Charity League 1998
Mother of Sugar Plum Cotillion Debutante 1997 to 2001
Secretary & Vice President of Choir Booster – Cypress Creek HS Choir 1998- 2001
Grade Level Advisor for 7th Grade for National Charity League 2002-2003
50 Hour Award for National Charity League – 2002-2003
National Charity League Mother Daughter Most Philanthropy Hour Award – 2003

6-85

Planning and Zoning Commission

4 Positions expiring

Incumbents requesting another term:

- Robert Fudge
- Russell Judah
- Patrick McNulty
- Gary Olle

New Applications:

- James Helms

P+2

**CANDIDATE APPLICATION FORM
FOR COUNCIL-APPOINTED BOARDS, COMMITTEES &
COMMISSIONS**

Information disclosed on this application or any other attached document may be disclosed in public meetings. Please print clearly.

Board Preference 1: Planning and Zoning Commission

Board Preference 2: Development Standards Review Task Force

Name: Robert A. Fudge

Home Address: 200 West Atol Street, PO Box 3854

City: South Padre Island Zip: 78597 SPI Resident: 12 years

Home Telephone: 956-772-1305 Home Fax: 956-772-1303

Home E-Mail: rfudge@rgv.rr.com

Profession: Professional Engineer

Business Name: Fudge Consulting, PLLC

Business Address: PO Box 3854

City: South Padre Island State: Texas Zip: 78597

Business Telephone: 956-433-9001

Business E-Mail: bob@fudgeconsulting.com

Special Knowledge or Experience applicable to City or Board/Commission Function:

Please see attachment

Other Information (Civic Activities):

Please see attachment

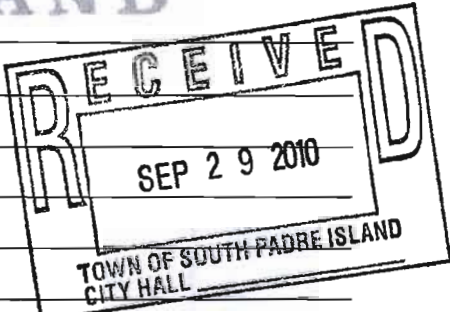

I verify that the information I have provided in this application to be true and correct. I also acknowledge that this information may be made available to the public.

Robert A. Fudge
Signature

September 27, 2010
Date

PLEASE RETURN COMPLETED APPLICATION TO THE CITY SECRETARY'S OFFICE, TOWN OF SOUTH PADRE ISLAND, 4601 PADRE BLVD., SOUTH PADRE ISLAND, TX 78597 OR FAX 956.761.3888.

6-87

**Candidate Application Form
Attachment "A"
For
Robert A. Fudge, P.E.**

Special Knowledge or Experience applicable to City or Board/Commission Function:

- Current Chairman of the Form Based Code Commission
- Current Chairman of Planning and Zoning Commission
- Member of Padre Boulevard Revitalization Committee
- Member of Padre Boulevard Implementation committee
- Member of South Padre Island Zoning Commission for Cameron County
- Member of South Padre Island Zoning Board of Adjustments for Cameron County
- Former Public Works Director for the Town of South Padre Island
- Former Assistant Emergency Management Coordinator for Town of South Padre Island

Other Information (Civic Activities):

- Member of the Laguna Madre Water District Board of Directors
- Member of South Padre Island Chamber of Commerce Board of Directors
- Member of the Laguna Madre Education Foundation Board of Directors
- Secretary of the Laguna Madre Water District Board of Directors
- Treasurer of South Padre Island Chamber of Commerce Board of Directors
- Treasurer of Laguna Madre Education Foundation Board of Directors
- Member of Port Isabel Chamber of Commerce
- Member of Port Isabel Rotary Club
- Program Chairman for the Port Isabel Rotary Club
- Member of the National Society of Professional Engineers
- Member of the Texas Society of Professional Engineers
- Member of the American Public Works Association
- Member of the American Water Works Association
- Member of the International Code Council
- Certified Windstorm Engineer by Texas Department of Insurance

6-88



Town of South Padre Island – Boards and Commissions Questionnaire
 4601 Padre Blvd. Phone: 956.761.6456
 South Padre Island, TX 78597 Fax: 956.761.3888

APPLICANT INFORMATION

Last Name: Fudge First: Robert M.I.: A Date: 9/27/10

Street Address: 200 West Atol Apartment/Unit #: 4

City: South Padre Island State: Texas Zip: 78597

Phone: 956-772-1305 E-mail Address: rfudge@rgv.rr.com

Occupation (Place of Business): Fudge Consulting, PLLC Phone: 956-433-9001

Are you a citizen of the United States? Yes No

Have you ever been convicted of a felony? Yes No If yes, please explain _____

Have you ever been convicted of, received Yes If yes, No please explain: Traffic Citation probation or deferred adjudication for any offense that was not a felony?

Do you have a current Driver's License? Yes No

Have you been a resident of the Town of South Padre Island for at least six (6) months prior to the date of application? Yes No

If qualified, are you a registered South Padre Island voter? Yes No

Are you an adversary party to pending litigation against the Town of South Padre Island? Have you ever been an adversary part to litigation against the Town of South Padre Island? Yes No If yes, please explain: _____

Are you an employee or a business associate of either an adversary party or a representative of an adversary party in any past or pending litigation against the Town of South Padre Island, other than an eminent domain proceeding? Yes No If yes, please explain: _____

Are you an employee or a business associate of either an adversary party or a representative of an adversary party that has a pecuniary interest in any past or pending litigation or claim against the Town of South Padre Island, other than an eminent domain proceeding? Yes No If yes, please explain: _____

Are you in arrears on any Town of South Padre Island taxes, water service charge or other obligations owned to the Town of South Padre Island? Yes No If yes, please explain: _____

Provide All Information Requested: INCOMPLETE APPLICATIONS WILL NOT BE CONSIDERED FOR BOARD/COMMISSION OPPORTUNITIES. Your complete application form will be maintained in our active files for six(6) months from the date of the application. I understand that should I not be appointed to the Town of South Padre Island board and commission, this application and any other records obtained, collected or otherwise prepared regarding this application shall be maintained in accordance with the Texas Public Information Act and the Town of South Padre island's document retention schedule.

6-89

DISCLAIMER AND SIGNATURE

I certify that my answers are true and complete. I understand that the information contained in this application may be considered, among other criteria, qualifications and/or information, by the City Council in its evaluation for the position being sought. I further understand that should I be appointed to any Town of South Padre Island commission, I serve at the pleasure of the Town Board of Aldermen and may be removed from said position at any time and for any reason or no reason at all, with or without notice. I also understand that should I be appointed to a Town of South Padre Island Board or Commission, I must be responsible for a creditable record of attendance and performance. If this application leads to my appointment to a position on a Town of South Padre Island Board or Commission, I understand that false or misleading information in my application may result in my removal from the position.

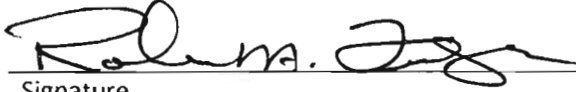
Signature

September 27, 2010

Date

6-90

**CANDIDATE APPLICATION FORM
FOR COUNCIL-APPOINTED BOARDS, COMMITTEES &
COMMISSIONS**

Information disclosed on this application or any other attached document may be disclosed in public meetings. Please print clearly.

Board Preference 1: PLANNING AND ZONING COMMISSION

Board Preference 2: DEVELOPMENT STANDARDS REVIEW TASK FORCE

Name: JAMES C. HELMS

Home Address: 115 EAST PALMETTO

City: SOUTH PADRE ISLAND Zip: 78597 SPI Resident: 10 years

Home Telephone: 7611932 Home Fax: _____

Home E-Mail: _____

Profession: RETIRED

Business Name: _____

Business Address: _____

City: _____ State: _____ Zip: _____

Business Telephone: _____

Business E-Mail: _____

Special Knowledge or Experience applicable to City Committee Function:

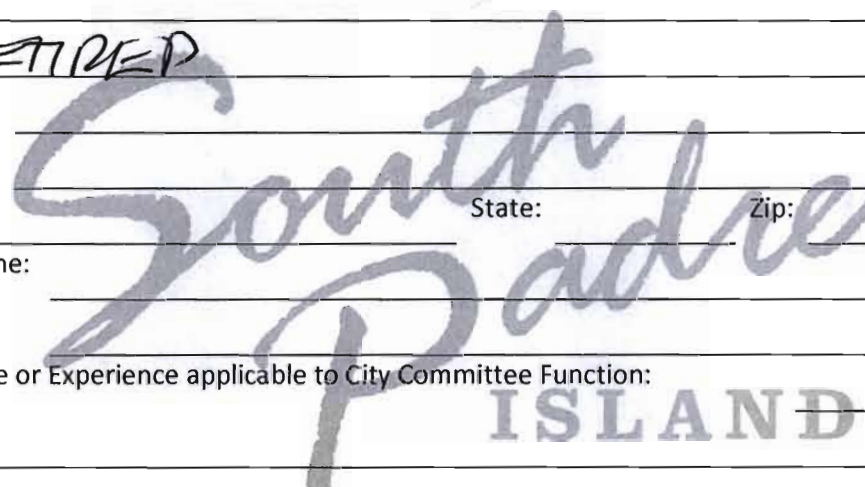

Other Information (Civic Activities): _____

I verify that the information I have provided in this application to be true and correct. I also acknowledge that this information may be made available to the public.

[Handwritten Signature]
Signature

9/27/10
Date

PLEASE RETURN COMPLETED APPLICATION TO THE CITY SECRETARY'S OFFICE, CITY OF SOUTH PADRE ISLAND, 4601 PADRE BLVD., SOUTH PADRE ISLAND, TX 78597; EMAIL SHILL@SOUTHPADRETEXAS.GOV OR FAX 956/761-3888.

Susan



City of South Padre Island – Committees, Boards and Commissions
Questionnaire
4601 Padre Blvd.
South Padre Island, TX 78597
Phone: 956/761-6456
Fax: 956/761-3888

APPLICANT INFORMATION

Last Name: HELMS First: JAMES M.I.: C Date: 9/27/10
Street Address: 115 EAST PALMETTO Apartment/Unit #: _____
City: SOUTH PADRE ISLAND State: TX Zip: 78597
Phone: 7611932 E-mail Address: _____
Occupation (Place of Business): RETIRED Phone: _____

Are you a citizen of the United States? Yes No

Have you ever been convicted of a felony? Yes No If yes, please explain: _____

Have you ever been convicted of, received probation or deferred adjudication for any offense that was not a felony? Yes No If yes, please explain: _____

Do you have a current Driver's License? Yes No

Have you been a resident of the City of South Padre Island for at least six (6) months prior to the date of application? Yes No

If qualified, are you a registered South Padre Island voter? Yes No

Are you an adversary party to pending litigation against the City of South Padre Island? Have you ever been an adversary part to litigation against the City of South Padre Island? Yes No If yes, please explain: _____

Are you an employee or a business associate of either an adversary party or a representative of an adversary party in any past or pending litigation against the City of South Padre Island, other than an eminent domain proceeding? Yes No If yes, please explain: _____

Are you an employee or a business associate of either an adversary party or a representative of an adversary party that has a pecuniary interest in any past or pending litigation or claim against the City of South Padre Island, other than an eminent domain proceeding? Yes No If yes, please explain: _____

Are you in arrears on any City of South Padre Island taxes, water service charge or other obligations owned to the City of South Padre Island? Yes No If yes, please explain: _____

Provide All Information Requested: INCOMPLETE APPLICATIONS WILL NOT BE CONSIDERED FOR COMMITTEE, BOARD OR COMMISSION OPPORTUNITIES. Your complete application form will be maintained in our active files for six (6) months from the date of the application. I understand that should I not be appointed to the City of South Padre Island committee, board or commission, this application and any other records obtained, collected or otherwise prepared regarding this application shall be maintained in accordance with the Texas Public Information Act and the City of South Padre Island's document retention schedule.

6-92

DISCLAIMER AND SIGNATURE

I certify that my answers are true and complete. I understand that the information contained in this application may be considered, among other criteria, qualifications and/or information, by the City Council in its evaluation for the position being sought. I further understand that should I be appointed to any City of South Padre Island committee, board, or commission, I serve at the pleasure of the South Padre Island City Council and may be removed from said position at any time and for any reason or no reason at all, with or without notice. I also understand that should I be appointed to a City of South Padre Island Board or Commission, I must be responsible for a creditable record of attendance and performance. If this application leads to my appointment to a position on a City of South Padre Island Committee, Board or Commission, I understand that false or misleading information in my application may result in my removal from the position.

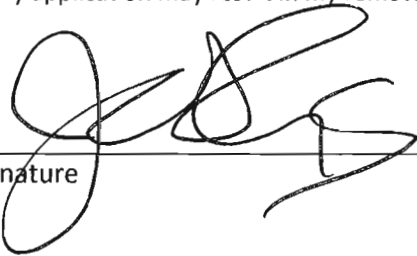

Signature

9/27/10

Date

**CANDIDATE APPLICATION FORM
FOR COUNCIL-APPOINTED BOARDS, COMMITTEES &
COMMISSIONS**

Information disclosed on this application or any other attached document may be disclosed in public meetings. Please print clearly.

Board Preference 1: PLANNING & ZONING COMMISSION

Board Preference 2: _____

Name: RUSSELL J. JUDAH

Home Address: BOX 3924

City: SO. PADRE ISLAND Zip: 78597 SPI Resident: 21 years

Home Telephone: 956.761.2702 Home Fax: NONE

Home E-Mail: ONLY IF APPOINTED NOT FOR PUBLICATION

Profession: RETIRED ENGR MGR - PROFESSIONAL ENGR

Business Name: NONE

Business Address: N/A

City: N/A State: _____ Zip: _____

Business Telephone: N/A

Business E-Mail: N/A

Special Knowledge or Experience applicable to City or Board/Commission Function: _____

Other Information (Civic Activities): _____

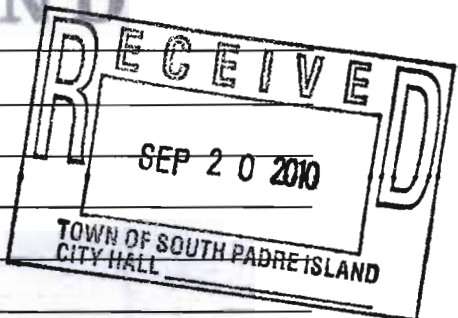

I verify that the information I have provided in this application to be true and correct. I also acknowledge that this information may be made available to the public.

Russell J Judah
Signature

18 Sept 2010
Date

PLEASE RETURN COMPLETED APPLICATION TO THE CITY SECRETARY'S OFFICE, TOWN OF SOUTH PADRE ISLAND, 4601 PADRE BLVD., SOUTH PADRE ISLAND, TX 78597 OR FAX 956.761.3888.

6-94

NOTE!



Town of South Padre Island – Boards and Commissions Questionnaire

4601 Padre Blvd.
South Padre Island, TX 78597

Phone: 956.761.6456
Fax: 956.761.3888

APPLICANT INFORMATION

Last Name: JUDAH First: RUSSELL M.I.: J Date: 18 Sept 2010

Street Address: Box 3924 Apartment/Unit #: ---

City: SPI State: TX Zip: 78597

Phone: 956.761.2702 E-mail Address: ---

Occupation (Place of Business): RETIRED Phone: ---

Are you a citizen of the United States? Yes No

Have you ever been convicted of a felony? Yes No If yes, please explain _____

Have you ever been convicted of, received probation or deferred adjudication for any offense that was not a felony? Yes No If yes, please explain: _____

Do you have a current Driver's License? Yes No

Have you been a resident of the Town of South Padre Island for at least six (6) months prior to the date of application? Yes No

If qualified, are you a registered South Padre Island voter? Yes No

Are you an adversary party to pending litigation against the Town of South Padre Island? Have you ever been an adversary part to litigation against the Town of South Padre Island? Yes No If yes, please explain: _____

Are you an employee or a business associate of either an adversary party or a representative of an adversary party in any past or pending litigation against the Town of South Padre Island, other than an eminent domain proceeding? Yes No If yes, please explain: NOT THAT I AM AWARE

Are you an employee or a business associate of either an adversary party or a representative of an adversary party that has a pecuniary interest in any past or pending litigation or claim against the Town of South Padre Island, other than an eminent domain proceeding? Yes No If yes, please explain: NOT THAT I AM AWARE

Are you in arrears on any Town of South Padre Island taxes, water service charge or other obligations owned to the Town of South Padre Island? Yes No If yes, please explain: _____

Provide All Information Requested: INCOMPLETE APPLICATIONS WILL NOT BE CONSIDERED FOR BOARD/COMMISSION OPPORTUNITIES. Your complete application form will be maintained in our active files for six(6) months from the date of the application. I understand that should I not be appointed to the Town of South Padre Island board and commission, this application and any other records obtained, collected or otherwise prepared regarding this application shall be maintained in accordance with the Texas Public Information Act and the Town of South Padre island's document retention schedule.

6-95

DISCLAIMER AND SIGNATURE

I certify that my answers are true and complete. I understand that the information contained in this application may be considered, among other criteria, qualifications and/or information, by the City Council in its evaluation for the position being sought. I further understand that should I be appointed to any Town of South Padre Island commission, I serve at the pleasure of the Town Board of Aldermen and may be removed from said position at any time and for any reason or no reason at all, with or without notice. I also understand that should I be appointed to a Town of South Padre Island Board or Commission, I must be responsible for a creditable record of attendance and performance. If this application leads to my appointment to a position on a Town of South Padre Island Board or Commission, I understand that false or misleading information in my application may result in my removal from the position.

Signature

18 Sept 2010
Date

6-96

**CANDIDATE APPLICATION FORM
FOR COUNCIL-APPOINTED BOARDS, COMMITTEES &
COMMISSIONS**

Information disclosed on this application or any other attached document may be disclosed in public meetings. Please print clearly.

Board Preference 1: Planning & Zoning

Board Preference 2: SDC

Name: Patrick Maulty

Home Address: 5813 Padre Blvd

City: South Padre Island Zip: TX SPI Resident: 6 years

Home Telephone: 956 761 2594 (No Contact) Home Fax: 956 761 6080

Home E-Mail: pmaulty@att.net

Profession: Construction

Business Name: Willis Development

Business Address: 5813 Padre Blvd

City: South Padre Island State: TX Zip: 78597

Business Telephone: 956 761 2040

Business E-Mail: N/A

Special Knowledge or Experience applicable to City or Board/Commission Function: Have served on Planning & Zoning for 3 1/2 years, was Vice Chairman for 1 year. Have served on Fire Station Financing Committee and Capital Improvement

Other Information (Civic Activities): NAR, NHAB,

I verify that the information I have provided in this application to be true and correct. I also acknowledge that this information may be made available to the public.

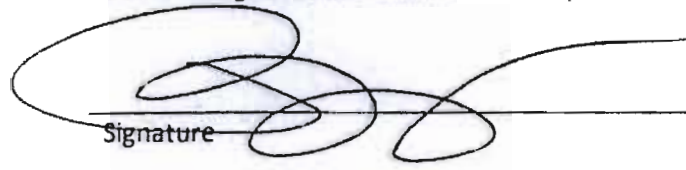
Signature

9/20/10
Date

PLEASE RETURN COMPLETED APPLICATION TO THE CITY SECRETARY'S OFFICE, TOWN OF SOUTH PADRE ISLAND, 4601 PADRE BLVD., SOUTH PADRE ISLAND, TX 78597 OR FAX 956.761.3888.

6-97



Town of South Padre Island – Boards and Commissions Questionnaire
 4601 Padre Blvd. Phone: 956.761.6456
 South Padre Island, TX 78597 Fax: 956.761.3888

APPLICANT INFORMATION

Last Name: M Smith First: Patrick M.I.: _____ Date: _____

Street Address: _____ Apartment/Unit #: _____

City: _____ State: _____ Zip: _____

Phone: _____ E-mail Address: _____

Occupation (Place of Business): _____ Phone: _____

Are you a citizen of the United States? Yes No

Have you ever been convicted of a felony? Yes No If yes, please explain _____

Have you ever been convicted of, received probation or deferred adjudication for any offense that was not a felony? Yes No If yes, please explain: a few speeding tickets

Do you have a current Driver's License? Yes No

Have you been a resident of the Town of South Padre Island for at least six (6) months prior to the date of application? Yes No

If qualified, are you a registered South Padre Island voter? Yes No

Are you an adversary party to pending litigation against the Town of South Padre Island? Have you ever been an adversary part to litigation against the Town of South Padre Island? Yes No If yes, please explain: _____

Are you an employee or a business associate of either an adversary party or a representative of an adversary party in any past or pending litigation against the Town of South Padre Island, other than an eminent domain proceeding? Yes No If yes, please explain: _____

Are you an employee or a business associate of either an adversary party or a representative of an adversary party that has a pecuniary interest in any past or pending litigation or claim against the Town of South Padre Island, other than an eminent domain proceeding? Yes No If yes, please explain: _____

Are you in arrears on any Town of South Padre Island taxes, water service charge or other obligations owned to the Town of South Padre Island? Yes No If yes, please explain: _____

Provide All Information Requested: INCOMPLETE APPLICATIONS WILL NOT BE CONSIDERED FOR BOARD/COMMISSION OPPORTUNITIES. Your complete application form will be maintained in our active files for six(6) months from the date of the application. I understand that should I not be appointed to the Town of South Padre Island board and commission, this application and any other records obtained, collected or otherwise prepared regarding this application shall be maintained in accordance with the Texas Public Information Act and the Town of South Padre island's document retention schedule.

U-98

DISCLAIMER AND SIGNATURE

I certify that my answers are true and complete. I understand that the information contained in this application may be considered, among other criteria, qualifications and/or information, by the City Council in its evaluation for the position being sought. I further understand that should I be appointed to any Town of South Padre Island commission, I serve at the pleasure of the Town Board of Aldermen and may be removed from said position at any time and for any reason or no reason at all, with or without notice. I also understand that should I be appointed to a Town of South Padre island Board or Commission, I must be responsible for a creditable record of attendance and performance. If this application leads to my appointment to a position on a Town of South Padre Island Board or Commission, I understand that false or misleading information in my application may result in my removal from the position.

Signature

Date

6-99

**CANDIDATE APPLICATION FORM
FOR COUNCIL-APPOINTED BOARDS, COMMITTEES &
COMMISSIONS**

Information disclosed on this application or any other attached document may be disclosed in public meetings. Please print clearly.

Board Preference 1: PiZ Commission

Board Preference 2: _____

Name: Gay Olle

Home Address: 7111 E. Morningside #303 / PO Box 2432

City: SPI Zip: 78597 SPI Resident: 15 years

Home Telephone: 761-8792 Home Fax: 761-8792

Home E-Mail: g-olle@sbcglobal.net

Profession: Bookkeeper / Semi-Retired

Business Name: Boot Jack

Business Address: 1900 N. Expressway

City: Brownsville State: TX Zip: 78521

Business Telephone: 546-2273

Business E-Mail: _____

Special Knowledge or Experience applicable to City or Board/Commission Function:

Current member of PiZ, member of the Home Rule Charter Commission, member - Chairman of DPRB (2 yrs)

Other Information (Civic Activities): Chairman Christmas Parade Committee (2 yrs)

Member of Laguna Madre Leadership - Class 8, member of Club Padre, Treasurer Padre Homeowners Association

I verify that the information I have provided in this application to be true and correct. I also acknowledge that this information may be made available to the public.

Gay Olle
Signature

9/29/2010
Date

PLEASE RETURN COMPLETED APPLICATION TO THE CITY SECRETARY'S OFFICE, TOWN OF SOUTH PADRE ISLAND, 4601 PADRE BLVD., SOUTH PADRE ISLAND, TX 78597 OR FAX 956.761.3888.

6-100



Town of South Padre Island – Boards and Commissions Questionnaire

4601 Padre Blvd.
South Padre Island, TX 78597

Phone: 956.761.6456
Fax: 956.761.3888

APPLICANT INFORMATION

Last Name: Olle First: Gary M.I.: H Date: _____
Street Address: 111 E. Morningside #303 Apartment/Unit #: 303
City: SPI State: TX Zip: 78597
Phone: 761-8792 E-mail Address: g_olle@stcglocal.net
Occupation (Place of Business): _____ Phone: _____

Are you a citizen of the United States? Yes No

Have you ever been convicted of a felony? Yes No If yes, please explain _____

Have you ever been convicted of, received probation or deferred adjudication for any offense that was not a felony? Yes No If yes, please explain: _____

Do you have a current Driver's License? Yes No

Have you been a resident of the Town of South Padre Island for at least six (6) months prior to the date of application? Yes No

If qualified, are you a registered South Padre Island voter? Yes No

Are you an adversary party to pending litigation against the Town of South Padre Island? Have you ever been an adversary part to litigation against the Town of South Padre Island? Yes No If yes, please explain: _____

Are you an employee or a business associate of either an adversary party or a representative of an adversary party in any past or pending litigation against the Town of South Padre Island, other than an eminent domain proceeding? Yes No If yes, please explain: _____

Are you an employee or a business associate of either an adversary party or a representative of an adversary party that has a pecuniary interest in any past or pending litigation or claim against the Town of South Padre Island, other than an eminent domain proceeding? Yes No If yes, please explain: _____

Are you in arrears on any Town of South Padre Island taxes, water service charge or other obligations owned to the Town of South Padre Island? Yes No If yes, please explain: _____

Provide All Information Requested: INCOMPLETE APPLICATIONS WILL NOT BE CONSIDERED FOR BOARD/COMMISSION OPPORTUNITIES. Your complete application form will be maintained in our active files for six(6) months from the date of the application. I understand that should I not be appointed to the Town of South Padre island board and commission, this application and any other records obtained, collected or otherwise prepared regarding this application shall be maintained in accordance with the Texas Public Information Act and the Town of South Padre island's document retention schedule.

6-101

DISCLAIMER AND SIGNATURE

I certify that my answers are true and complete. I understand that the information contained in this application may be considered, among other criteria, qualifications and/or information, by the City Council in its evaluation for the position being sought. I further understand that should I be appointed to any Town of South Padre Island commission, I serve at the pleasure of the Town Board of Aldermen and may be removed from said position at any time and for any reason or no reason at all, with or without notice. I also understand that should I be appointed to a Town of South Padre island Board or Commission, I must be responsible for a creditable record of attendance and performance. If this application leads to my appointment to a position on a Town of South Padre Island Board or Commission, I understand that false or misleading information in my application may result in my removal from the position.

Signature

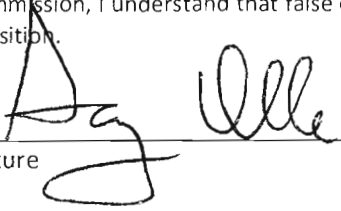
A handwritten signature in black ink, appearing to be "Agille", written over a horizontal line.

Date

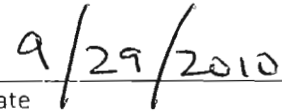
A handwritten date "9/29/2010" in black ink, written over a horizontal line.

6-102

**CITY OF SOUTH PADRE ISLAND
CITY COUNCIL MEETING
AGENDA REQUEST FORM**

MEETING DATE: October 6, 2010

NAME/DEPT.: R. R. Ridolfi, Council Member

ITEM:

Discussion and action on developing procedures and planning of projects for services and infrastructure to South Padre Island residents.

ITEM BACKGROUND

Over the past years, from time to time, the Council is chided for not delivering services, infrastructure, facilities, improvements, and other amenities for the benefit of SPI Residents. Moreover, the accusations are that the improvements and enhancements done seem to be more for the benefits of businesses and to attract tourists. So to gain a better understanding of the specific needs not addressed by the Boards and Councils over the past several years, I asked three highly respected citizens who are active in community activities, to define in specific terms what they believe and recommend that the City should do to improve the quality of life for residents. I took notes, listened and without comments on the merits or disincentives of their suggestions.

The meeting resulted from a series of emails I had with a citizen concerning the need for the City to address the needs and wants of residents. And in doing so, we may also attract new residents; "People we want to attract and to make people want to live on the Island, fulltime." in the words of one of the group.

I will meet anytime with any person or group who would like to have this discussion.

Some of the improvements recommended are not new. We have done less of each than we could have done. Some require new emphasis and attention. All are worthy of the Council Members serious consideration and action. The following summary of actions words are mine. I did gain coordination on most. The list of eight carries my emphasis, word selection and meaning, not necessarily that of the participants. Therefore I have asked the three respected citizens to make public comment during this Council Meeting so that we have the benefit of their thinking..

Here is the list of eight suggestions:

1. **Street improvements and sidewalks.** Some have been done but why not do more where residents live too. More sidewalks are needed in more areas, not just the tourist area. Maybe we could overlay the blacktop in some areas now, TXDOT? Why not add some to streets in the North of Town.
2. **More Bus Shelters.** These are attractive and appeal to residents. We should add more bus stops. These demonstrate to the residents that how government can spend money for the common good of all inhabitants.
3. **Add More Benches.** People do walk our streets. Look at Laguna Blvd, Gulf Blvd and Padre Blvd; there have very few if any on Laguna Blvd and they are not expensive. Find space or seek permission.
4. **Replace the Palms.** Some have failed while others have been removed. Let's use other than Washingtonian Palms that grow into too tall poles. Look at Laguna Blvd and dress it up. Maybe add color too.
5. **The library Annex is a Plus.** It is dreadfully small. It needs more room and the residents like it. This is an asset for SPI.
6. **The Island Feels Safe.** Services save lives and resident know that. That safe feeling attracts residents. It is best to spend money on staff than on vehicles that sit unused in our parking lots. Let's try to reduce these. It is best to also spend money on infrastructure than one year consumables.
7. **Pocket Parks are desired.** The Water Park is an embarrassment. It needs improvements now, not next year. It is unattractive, dull and without any color in plants. People use it. Fix it.
8. **Our past surveys have not produced insight to the needs and wants of our residents.** Why not structure a City Webpage with an open question that asks residents what the city can to improve their lives.

RECOMMENDATIONS:

- A. RECOMMENDATION; The City Manager use this list to implement Resident-Friendly Improvements this year as money becomes available.
- B. That the City Manager report progress to implement these improvements to the Council and the Citizens at the first Council meeting of each month until ACTION IS COMPLETED.
- C. While many of these actions are not big expenditure, collectively they add to be large funding requirements. The intent is to find money in the budget over the year of operation to aggressively fund these without budget damage.

BUDGET/FINANCIAL SUMMARY

COMPREHENSIVE PLAN GOAL

COUNCIL ACTION

Motion: _____

Second: _____

Vote: Ayes: _____ **Nays:** _____

Abstentions: _____

**CITY OF SOUTH PADRE ISLAND
CITY COUNCIL MEETING
AGENDA REQUEST FORM**

MEETING DATE: October 6, 2010

NAME/DEPT.: Joni Clarke, City Manager's Office

ITEM

Consideration and action regarding the Texas Chapter of the American Shore and Beach Preservation Association (ASBPA) and its Coastal Legislative Agenda for the upcoming 82nd Texas Legislative Session.

ITEM BACKGROUND

The Texas Chapter of the American Shore and Beach Preservation Association (ASBPA) at its October 29 meeting to be held at the Harte Research Institute on the Texas A&M University campus in Corpus Christi will be preparing its Coastal Agenda and of particular importance will be the discussion regarding funding strategies.

Some of the ideas that the Texas Chapter of the ASBPA will be considering include:

1. Transaction fee on the sale of real estate in the first two tier coastal counties along the Texas Coast, excluding Harris County. We would request the members to nurture ground support from the various real estate firms to support the legislation. We need the ground support because the Texas Realtor Association usually fights these requests and have killed it in the past. This is how Florida and New Jersey obtain a largest portion of their funds. Suggest \$100 and classify as Shoreline Restoration Fee.
2. A fee on rental of residential property rented less than 6 months from Spring Break to Labor Day possibly in the first two tier coastal counties with the exception of Harris County. Suggest 1% of rental fee and classify as Shoreline Restoration Fee
3. A special gas tax for the coastal counties. Fee to be determined.
4. Request a portion of the environmental fees for the coast. Fee to be determined.
5. A fee for people getting motor traffic violations. Fee to be determined.

6. A fee added to Windstorm Insurance policy. Suggest \$50 as Shoreline Restoration Fee.

The Texas Chapter of ASBPA would like to consider your ideas about funding sources and any other ideas for the October 29 meeting.

RECOMMENDATIONS/COMMENTS

In discussing the Coastal Legislative Agenda with Clint Smith of Hillco, he reminded me of the transportation initiative that “went down in flames” during the last legislative session when many of the major cities tried to find ways to fund transportation projects. Clint is planning on attending this meeting and representatives from the General Land Office are planning to attend as well. We have two funding streams that we are going to be pushing, CIAP (3 mil) and CEPRA (3 mil) to piece together funding for the off shore sand source project. We will also be meeting with Michael Willis on Tuesday, October 26th to discuss our federal projects. Staff and Hillco is seeking Council direction on how to best represent the City of South Padre Island’s goals for this legislative session.

BUDGET/FINANCIAL SUMMARY

N/A

COMPREHENSIVE PLAN GOAL

N/A

COUNCIL ACTION

Motion: _____

Second: _____

Vote: Ayes: _____ Nays: _____

Abstentions: _____

8.2

**CITY OF SOUTH PADRE ISLAND
CITY COUNCIL WORKSHOP
AGENDA REQUEST FORM**

MEETING DATE: October 6, 2010

NAME/DEPT.: Tim Howell, Information Services Director

ITEM

Discussion and action on the Beachcomber – 2010 Bond Election Special Edition for the Fire and Emergency Services Station Bond Election

ITEM BACKGROUND

For postal saving reasons we are combining the Beachcomber 4th Quarter edition and 2010 Bond Proposal Brochure to have a special edition containing the Fire and Emergency Services Station information

RECOMMENDATIONS/COMMENTS

We recommend the usage of all of our communication and media outlets

BUDGET/FINANCIAL SUMMARY

COMPREHENSIVE PLAN GOAL

6.J Continue to support the needs of the Public Works, Police and Fire Departments to ensure adequate protection of the population.

6.19 Plan and budget for additional fire and police staffing and their requisite vehicles, equipment, and facilities.

COUNCIL ACTION

Motion: _____

Second: _____

Vote: Ayes: _____ **Nays:** _____

Abstentions: _____

**CITY OF SOUTH PADRE ISLAND
CITY COUNCIL MEETING
AGENDA REQUEST FORM**

MEETING DATE: October 6, 2010

NAME/DEPT.: Darla A. Jones, Assistant City Manager

ITEM

Discussion regarding drainage issues on South Padre Island.

ITEM BACKGROUND

See attached background material.

RECOMMENDATIONS/COMMENTS

None, discussion only.

BUDGET/FINANCIAL SUMMARY

No effect on budget.

COMPREHENSIVE PLAN GOAL

N/A

COUNCIL ACTION

Motion: _____

Second: _____

Vote: Ayes: _____ **Nays:** _____

Abstentions: _____

Drainage Issues Facing South Padre Island

South Padre Island has many unique challenges related to storm water drainage. The first and probably most challenging issue is that we are barely above sea level. To put it into perspective, Brownsville is about 25 feet above sea level, Harlingen averages about 35 feet, La Feria is about 55 feet, and McAllen is about 110'. Padre Blvd averages 2.5'.

Our storm water must, by law, drain west into the Laguna Madre. So, storm water that falls on Gulf Blvd must flow to the west to the Bay. Our storm water system is comprised of inlets, pipes and some curb and gutter. The pipes that carry the storm water underground west, outfall into the Bay. Our ability to drain storm water is very dependent on the tides. As previously mentioned, Padre Blvd is only about 2.5 feet above sea level so if our tides are up, those pipes may be underwater, depending on the tide levels at the time. During bad storms, the tides tend to run higher than normal as well, further compounding the problem. The tide levels also have an impact on the groundwater levels as well.

Another issue we face is our groundwater. When we have a storm event that drops several inches of rain, most of that water seeps in to the ground, accumulates and raises our groundwater. We've had instances where we've pumped standing water off of a lot only to have it flooded again the next day when it hasn't rained anymore. The groundwater seeps up.

Yet another issue is the topography of the Island. Gulf Blvd sits at about 8' above sea level, Laguna sits at about 5', and as previously mentioned, Padre is at about 2.5. So, Padre is the low spot, street-wise. We have a series of underground storm water pipes that are supposed to carry the storm water under Padre Blvd to the west and empty into the Bay. In examining those pipes, most of them were installed more than 30 years ago and they flow FROM WEST TO EAST under Padre Blvd.. So, this is believed to be the main reason Padre holds water after a storm event.

**SOUTH PADRE ISLAND
CITY COUNCIL MEETING
AGENDA REQUEST FORM**

MEETING DATE: October 6, 2010

NAME/DEPT.: Reuben Trevino, Coastal Resources Manager

ITEM

Discussion and Action on the ammendmant of the beachfront construction certificate and dune protection permit for Robert Fudge previously approved on August 5, 2009.

ITEM BACKGROUND

Amendment includes expanding the overall footprint of the deck and the addition of a covered pavilion to the deck. The BDTF met on September 27, 2010 and unanimously voted to recommend approval of the application as submitted.

RECOMMENDATIONS/COMMENTS

Staff recommends the approval of the amedmant request.

BUDGET/FINANCIAL SUMMARY

COMPREHENSIVE PLAN GOAL

COUNCIL ACTION

Motion: _____

Second: _____

Vote: Ayes: _____ **Nays:** _____

Abstentions: _____

**BEACH & DUNE TASK FORCE
MEETING
AGENDA REQUEST FORM**

MEETING DATE:

ITEM:

SPONSOR / ORIGINATOR: Robert Fudge

ITEM DESCRIPTION:

Discussion and Action on the amendment of an existing beachfront construction certificate and dune protection permit for Robert Fudge on a project that includes the removal of an existing retaining wall and construct a new retaining wall, fence, and wooden deck farther inland and in accordance with the Town of South Padre Island provisions for construction of retaining walls landward of the HBL. The applicant will mitigate 255 cubic yards of impacts to dunes and dune vegetation seaward of the HBL and use 50 cubic yards of river sand as a core for the dune restoration project.

Amendment includes expanding the overall footprint of the deck and the addition of a covered pavilion to the deck.

DISCUSSION:

The application and the GLO comment letter are attached.

COMMENTS / RECOMMENDATIONS:

The existing retaining wall that is located seaward of the line 200 ft west and parallel to the mean low tide will be removed and no longer encroach upon the public beach. The new retaining wall will be located landward of the HBL and more than 200 feet landward of mean low tide.

Mr. Brashear has worked with town staff and the GLO to insure the new retaining wall does not encroach upon the public beach. He has agreed to move the location of the retaining wall west of the HBL and build a dune in front of that wall.

Mr. Brashear proposes to use 50 cubic yards of river sand as a core for the dune restoration project. The GLO has reviewed the sample submitted to them and find it acceptable material for dune restoration. If the material creates a non beach quality sand residue, the applicant will be responsible for removing the residue from the beach. Town staff agrees with the GLO's recommendations.

TASK FORCE ACTION:

MOTION: _____

BY: _____

SECOND BY: _____

Munnarriz	Marikos	Blatnik	Brommer	Marsden	Nixon	Haynes/ Wierenga
Yes	Yes	Yes	Yes	Yes	Yes	Yes

11-2

**BEACH & DUNE TASK FORCE
MEETING
AGENDA REQUEST FORM**

No
Abstain

No
Abstain

No
Abstain

No
Abstain

No
Abstain

No
Abstain

No
Abstain

TEXAS



GENERAL LAND OFFICE

JERRY PATTERSON, COMMISSIONER

September 21, 2010

Via Electronic Mail

Mr. Reuben Trevino
City of South Padre Island
P.O. Box 3410
South Padre Island, Texas 78597-3410

Beach and Dune Construction/Protection Permit in the Town of South Padre Island

Site Address: 7200 Padre Boulevard
Legal Description: Lot 2, Contran Subdivision
Lot Applicant: Robert Fudge/Clayton Brashear
GLO ID No.: BDSPI-09-0048a

Dear Mr. Trevino:

The General Land Office has reviewed the application for an amendment to previously issued dune protection permit and beachfront construction certificate for the above-referenced location. In addition to the previously permitting construction, the applicant proposes to expand the footprint of the deck and add a covered pavilion to the deck. The proposed construction is located less than 200 feet from the line of vegetation and landward of the HBL in an area that, according to the Bureau of Economic Geology, is eroding at the rate of 6 feet per year.

Based on the materials forwarded to our office for review, we have the following comment:

- The City of South Padre Island shall require the permittee to use the mitigation sequence as a condition of the permit and must require the permittee to follow the order of the mitigation sequence by demonstrating avoidance, minimization, mitigation and compensation for all impacts to dunes and dune vegetation.¹

If you have any questions, please contact me by phone at (512) 463-9309 or by email at angela.sunley@glo.state.tx.us.

¹ 31 TAC §15.4(f).

Page 2 of 2
September 21, 2010
Mr. Trevino
BDSPI-10-0002

Sincerely,



Angela Sunley
Beach/Dune Team Leader
Coastal Resources Program
Texas General Land Office

11-5



FUDGE CONSULTING, PLLC

P.O. Box 3854

South Padre Island, Texas 78597

September 7, 2010

Reuben Trevino
Coastal Resources Manager
City of South Padre Island
4601 Padre Boulevard
South Padre Island, Texas 78597

RE: Beach and Dune Permit Amendment
7200 Padre Boulevard
Lot 2, Contran Subdivision
Clayton Brashear, Property Owner
GLO ID No. BDSPI-09-0048

Dear Reuben:

Please accept this as our official request for an amendment to the above referenced permit approved by the City in July, 2009.

The owner would like to amend this permit to place a covered wood structure, 70 x 70, on a wood deck, approximately 200 feet long and ranging from 80' to 150' in width, which is larger than the one included in the original permit. Each of these items will be behind the historic building line, and behind the new seawall included in the original permit.

Attached please find two plan sheets detailing these proposed changes. One sheet is a site plan and one is a detail sheet. Please note the proposed 24' Jet Ski ramp will not be built. We have also attached another copy of the survey from the original application.

If you need any additional information for the processing of this request, please let us know and we will provide the data promptly.

Thank you for your assistance with this request.

FUDGE CONSULTING, PLLC

Robert A. Fudge, P.E.
Applicant/Agent for Owner

Attachments

LA QUINTA HOTEL

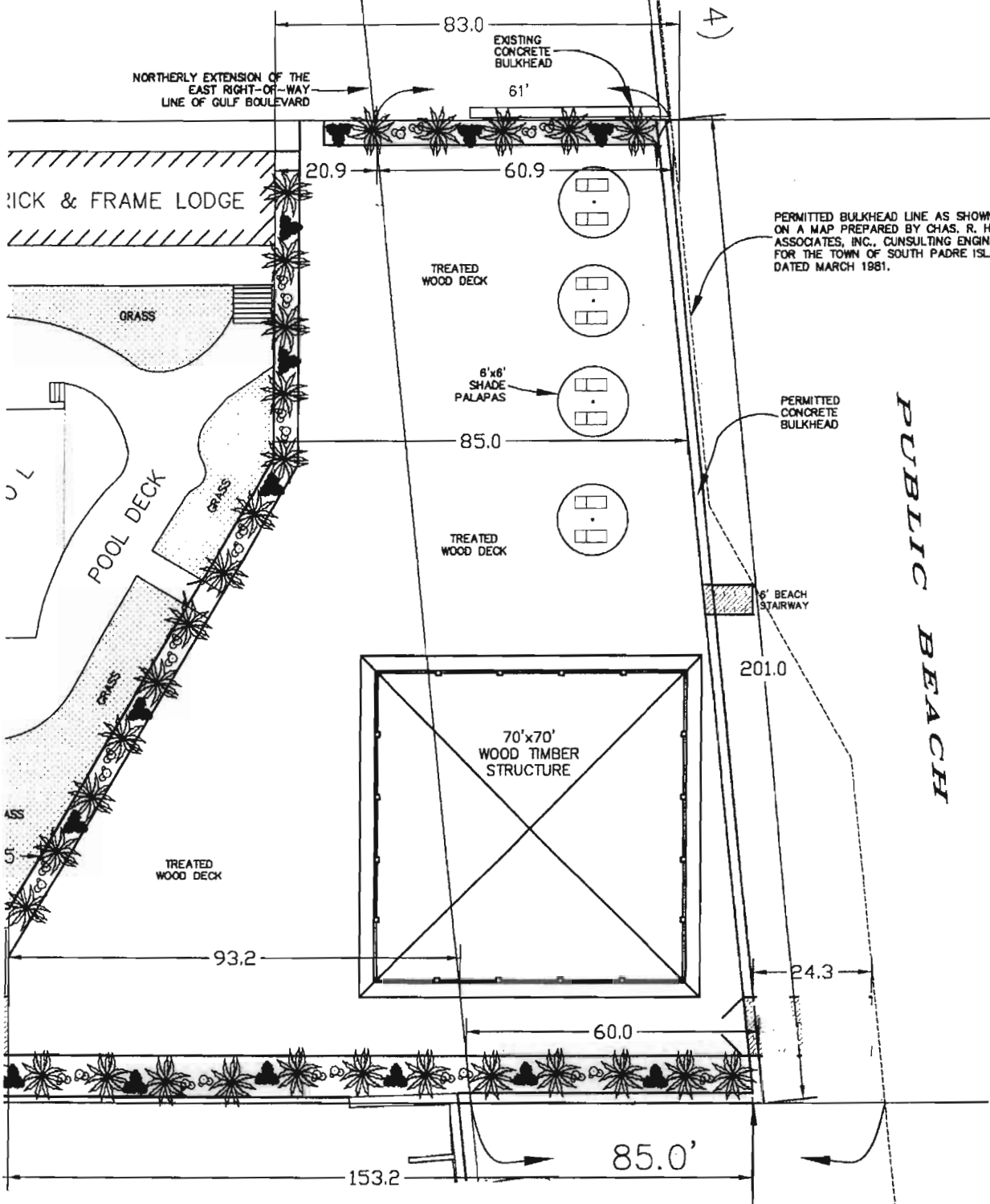

PERMITTED BULKHEAD LINE AS SHOWN ON A MAP PREPARED BY CHAS. R. HALE ASSOCIATES, INC., CONSULTING ENGINEERS FOR THE TOWN OF SOUTH PADRE ISLAND DATED MARCH 1981.

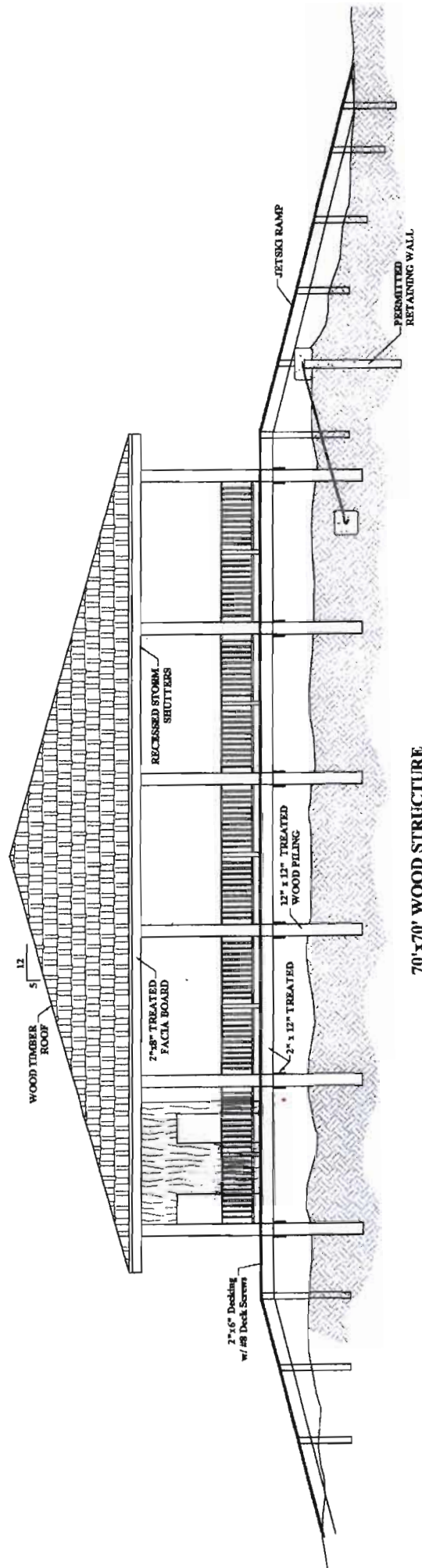

70' x 70' WOOD STRUCTURE
SOUTH ELEVATION
(N.T.S.)

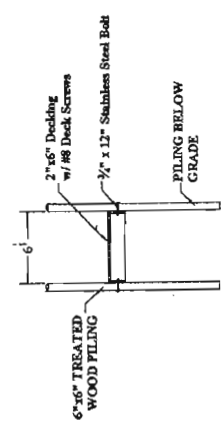

STAIRWAY
DETAIL
TO BEACH
(N.T.S.)

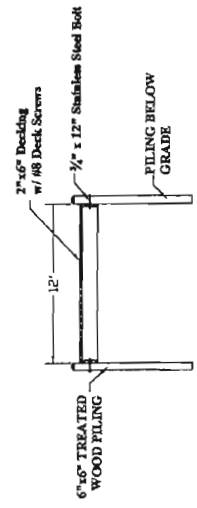

JETSKI RAMP DETAIL
TO BEACH
(N.T.S.)

CLAYTON BRASHEAR
BEACH FRONT DETAILS



SCALE 1" = 20'

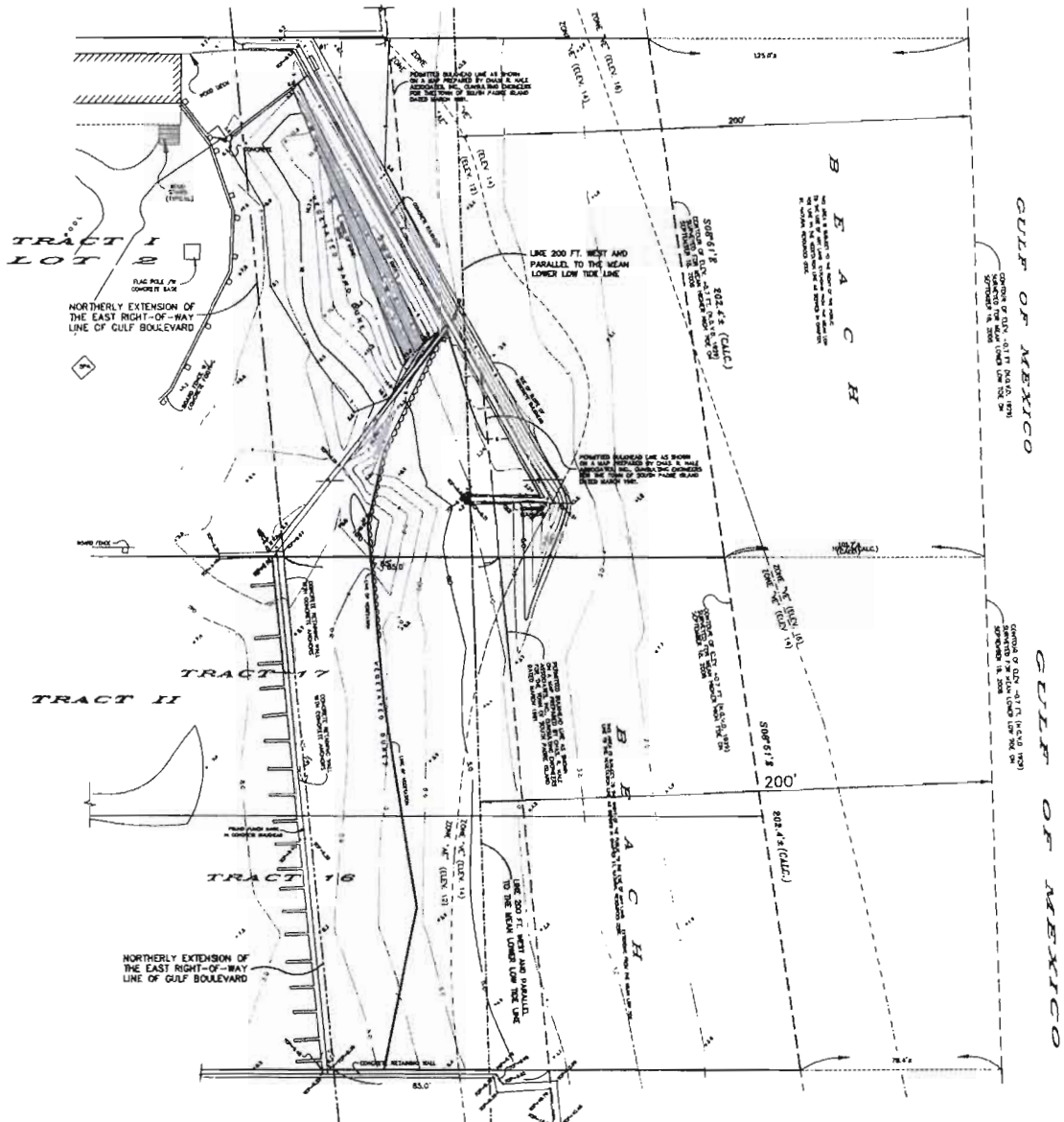
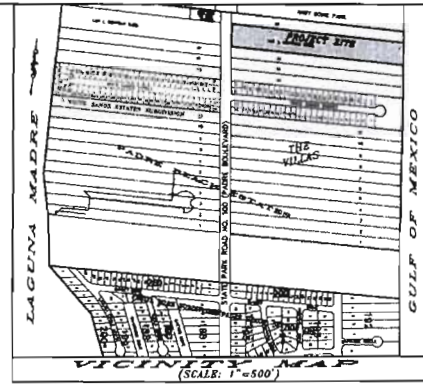

TOPOGRAPHIC SURVEY

TRACT I: THAT PORTION BETWEEN THE NORTHERLY EXTENSION OF THE EAST RIGHT-OF-WAY LINE OF GULF BOULEVARD AND THE MEAN LOWER LOW TIDE OF THE GULF OF MEXICO, LYING WITHIN LOT 2, CONTRAN SUBDIVISION, IN THE TOWN OF SOUTH PADRE ISLAND, CAMERON COUNTY, TEXAS, RECORDED IN CABINET I, SLOT 1416-A, MAP RECORDS OF CAMERON COUNTY, TEXAS.

TRACT II: THAT PORTION BETWEEN THE NORTHERLY EXTENSION OF THE EAST RIGHT-OF-WAY LINE OF GULF BOULEVARD AND THE MEAN LOWER LOW TIDE OF THE GULF OF MEXICO, LYING WITHIN THAT PORTION OF TRACTS SIXTEEN (16) AND SEVENTEEN (17), PADRE BEACH ESTATES, RECORDED IN VOLUME 14, PAGE 61, MAP RECORDS, CAMERON COUNTY, TEXAS; ALL SAID TRACTS BEING IN THE TOWN OF SOUTH PADRE ISLAND, CAMERON COUNTY, TEXAS.

SURVEYED FOR:
CLAYTON BRASHEAR
(SURVEYED SEPTEMBER 17 & 18, 2008)

Mejia & Rose, Incorporated
Engineering Surveying
1643 West Price Road (958) 644-3028
P.O. Box 3781 Brownsville, Texas 78520
Fax (958) 644-3068

G.P. No. 5/A JOB No. 17436
1/2008 Pgs. 2, 3, 4

11-9

**SOUTH PADRE ISLAND
CITY COUNCIL MEETING
AGENDA REQUEST FORM**

MEETING DATE: October 6, 2010

NAME/DEPT.: Reuben Trevino, Coastal Resources Manager

ITEM

Discussion and Action on a beachfront construction certificate and dune protection permit for Miguel Torres to construct an ADA beach access ramp as described in the application.

ITEM BACKGROUND

The BDTF met on September 27, 2010 and unanimously voted to recommend approval of the application as submitted.

RECOMMENDATIONS/COMMENTS

Staff recommends the approval of the application as submitted.

BUDGET/FINANCIAL SUMMARY

COMPREHENSIVE PLAN GOAL

COUNCIL ACTION

Motion: _____

Second: _____

Vote: Ayes: _____ **Nays:** _____

Abstentions: _____

BEACH & DUNE TASK FORCE MEETING AGENDA REQUEST FORM
--

MEETING DATE:

ITEM:

SPONSOR / ORIGINATOR: Miguel Torres

ITEM DESCRIPTION:

Discussion and Action on a beachfront construction certificate and dune protection permit for Miguel Torres to construct an ADA beach access ramp as described in the application.

DISCUSSION:

The application and the GLO comment letter are attached.

COMMENTS / RECOMMENDATIONS:

Staff recommends approval of the application.

TASK FORCE ACTION:

MOTION: _____

BY: _____

SECOND BY: _____

Munnarriz	Marikos	Blatnik	Brommer	Marsden	Nixon	Haynes/ Wierenga
Yes	Yes	Yes	Yes	Yes	Yes	Yes
No	No	No	No	No	No	No
Abstain	Abstain	Abstain	Abstain	Abstain	Abstain	Abstain

TEXAS



GENERAL LAND OFFICE

JERRY PATTERSON, COMMISSIONER

September 21, 2010

Via Electronic Mail

Mr. Reuben Trevino
Town of South Padre Island
P.O. Box 3410
South Padre Island, Texas 78597-3410

Beachfront Construction Certificate and Dune Protection Permit in City of South Padre Island

Site Location: 6300 Padre Boulevard
Legal Description: Bahia Mar Condominiums
Lot Applicant: Miguel Torres
GLO ID No.: BDSPI-10-0351

Dear Mr. Trevino:

The General Land Office (GLO) has reviewed the application for a dune protection permit and beachfront construction certificate for the above-referenced location. The applicant proposes to construct a Texas Accessibility Standards compliant beach access ramp. The proposed construction is located seaward of the historic building line within the 10-foot maintenance area and in an area that, according to the Bureau of Economic Geology, is eroding at the rate of four feet per year.

Based on the materials forwarded to our office for review, we have no comments. If you have any questions, please contact me by phone at (512) 463-9309 or by email at angela.sunley@glo.state.tx.us.

Sincerely,

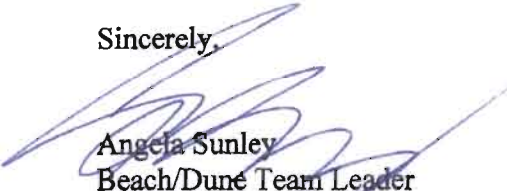
Angela Sunley
Beach/Dune Team Leader
Coastal Resources Division

Stephen F. Austin Building • 1700 North Congress Avenue • Austin, Texas 78701-1495

Post Office Box 12873 • Austin, Texas 78711-2873

512-463-5001 • 800-998-4GLO

www.glo.state.tx.us

12-3

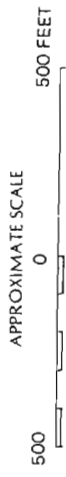

NATIONAL FLOOD INSURANCE PROGRAM

FIRM

FLOOD INSURANCE RATE MAP

TOWN OF
SOUTH PADRE ISLAND,
TEXAS
CAMERON COUNTY
ONLY PANEL PRINTED

NOTE:
THIS MAP INCORPORATES APPROXIMATE BOUNDARIES OF
SPECIAL STUDY AREAS, SPECIAL STUDY AREAS, AND
OTHERWISE PROTECTED AREAS ESTABLISHED UNDER THE
COASTAL BARRIER IMPROVEMENT ACT OF 1980 (P.L. 96-353).

COMMUNITY-PANEL NUMBER
480115 0001 D

MAP REVISED:
MARCH 9, 1999



Federal Emergency Management Agency

This is an official copy of a portion of the above referenced flood map. It was extracted using F-MIT On-Line. This map does not reflect changes or amendments which may have been made subsequent to the date on the title block. For the latest product information about National Flood Insurance Program flood maps check the FEMA Flood Map Store at www.msc.fema.gov

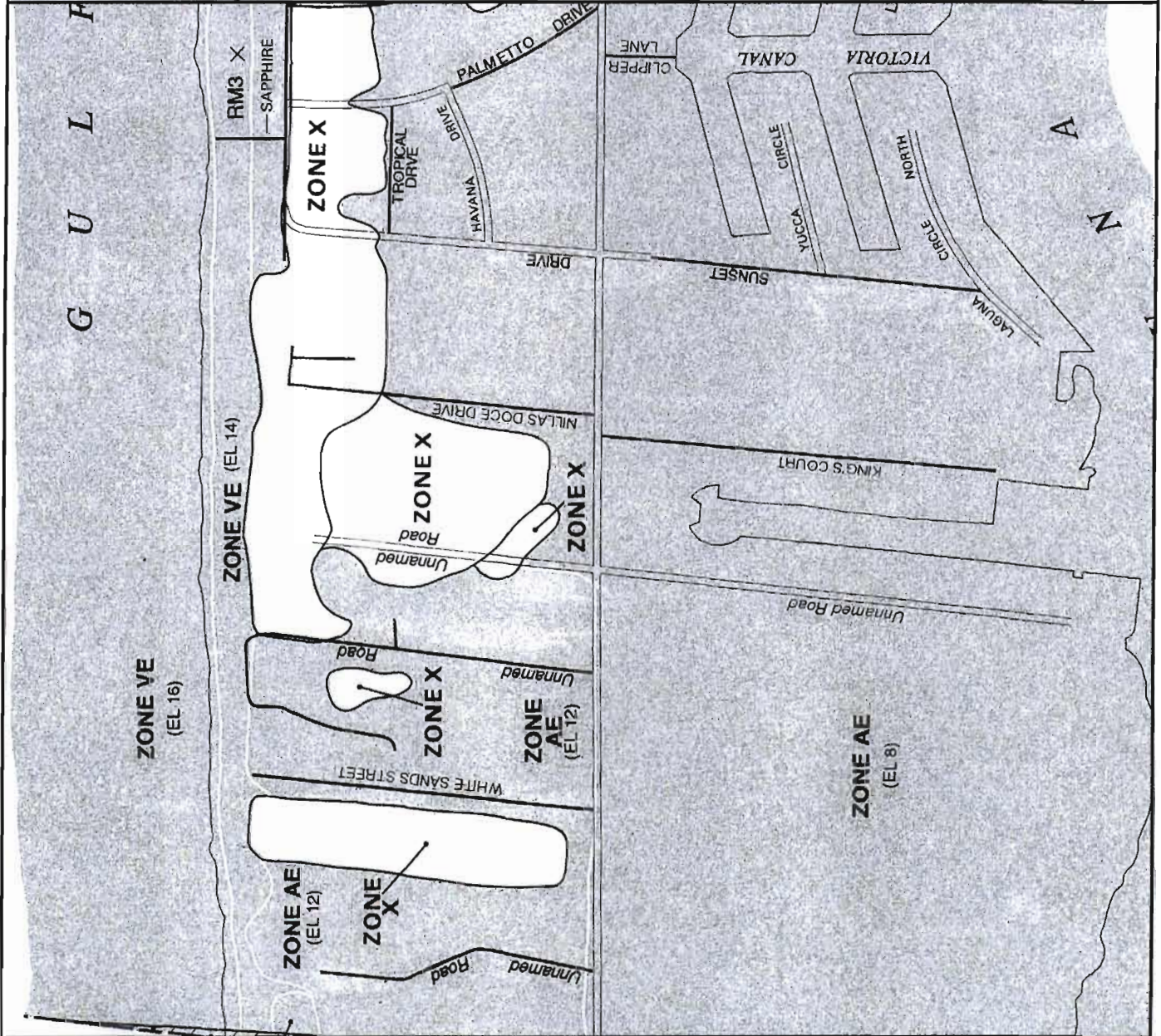

7-21

Town of South Padre Island
Beach & Dune Application



Site for Proposed Work:

Legal Description: BAHIA MAR CONDOMINIUMS

Physical Address: 6300 PADRE BOULEVARD

Property Owner Information:

Applicant/Agent for Owner:

Name: NEW BAHIA MAR MANAGEMENT
Mailing Address: 6300 PADRE BOULEVARD
City, State, Zip: SOUTH PADRE ISLAND TX 78597
Phone Number: 956-433-5480
Fax Number: _____
E:mail Address: _____

Name: MIGUEL TORRES
Mailing Address: 50 PADRE BOULEVARD
City, State, Zip: SOUTH PADRE ISLAND TX 78597
Phone Number: 956-701-9922
Fax Number: _____
E:mail Address: mtorres@taisaouthpadre.com

Applicant Signature: _____
Date of Signature: _____

I/We, owners of the above-mentioned property, authorize the applicant stated above, to act in my behalf in order to acquire a Beach and Dune permit for the construction proposed below. (owner initials here--> _____)

Owner(s) Signature(s): [Signature]
Date of Signature: 02/16/10

Project Description:

Describe with as much detail as possible, the construction proposed. If more room is needed, please include an additional page. Include the number of habitable units, amenities, swimming pools, fences, kinds of fences, whether footings and/or retaining walls will be installed, and locations of proposed landscaping and parking.

BEACH ACCESS HANDICAP RAMP

Total Square footage of footprint of habitable structure: 155 sq-ft (ESCALERA 5)
Total Area of Impervious surface (i.e. retaining walls, walkways, drives, patios, etc.): 430 sq-ft (NUEVA DAMPA)
Percentage of Impervious surface [(impervious surface / habitable footprint)* 100]: _____

Please Note: the percentage of impervious surface cannot exceed 5% in an eroding area.

Approximate Duration of Construction: _____

Financial Plan for the removal of all hard structures.

All Properties which are allowed to build retaining walls on their property are allowed to do so with the condition that a financial plan for the removal of the retaining wall is submitted to the Public Works Department of the Town of South Padre Island. Removal of the retaining wall at the owner's expense may be required if/once the retaining wall comes into regular contact with wave action for twenty (20) out of thirty (30) consecutive days. The Town accepts the submission of a Retaining Wall Covenant, or other financial guarantee, insuring the removal of the retaining wall if the required conditions are met.

Type of Plan submitted: _____ Date of submission: _____

Drainage:

Describe the impact that the proposed construction will have on the natural drainage pattern on the site and adjacent lots.

a) no change in the drainage on site. b) the proposed construction will change the grading and the drainage on the subject property. (An explanation will be required detailing where the water will drain.)

Explanation/other info: _____

Impacts to Beach/Dune System:

Answer each question as completely as possible in narrative form:

1) What damage will this proposed construction have on the dune vegetation located at the project site?

a) no damage to dune vegetation whatsoever.
b) the proposed construction will impact _____ % of the dune vegetation on site. (explanation of the "impact" will be required)
c) the proposed construction will require the removal and relocation of _____ % of the dune vegetation on site. (the submission of a mitigation plan will be required)

Explanation/other info: _____

More on back...-->

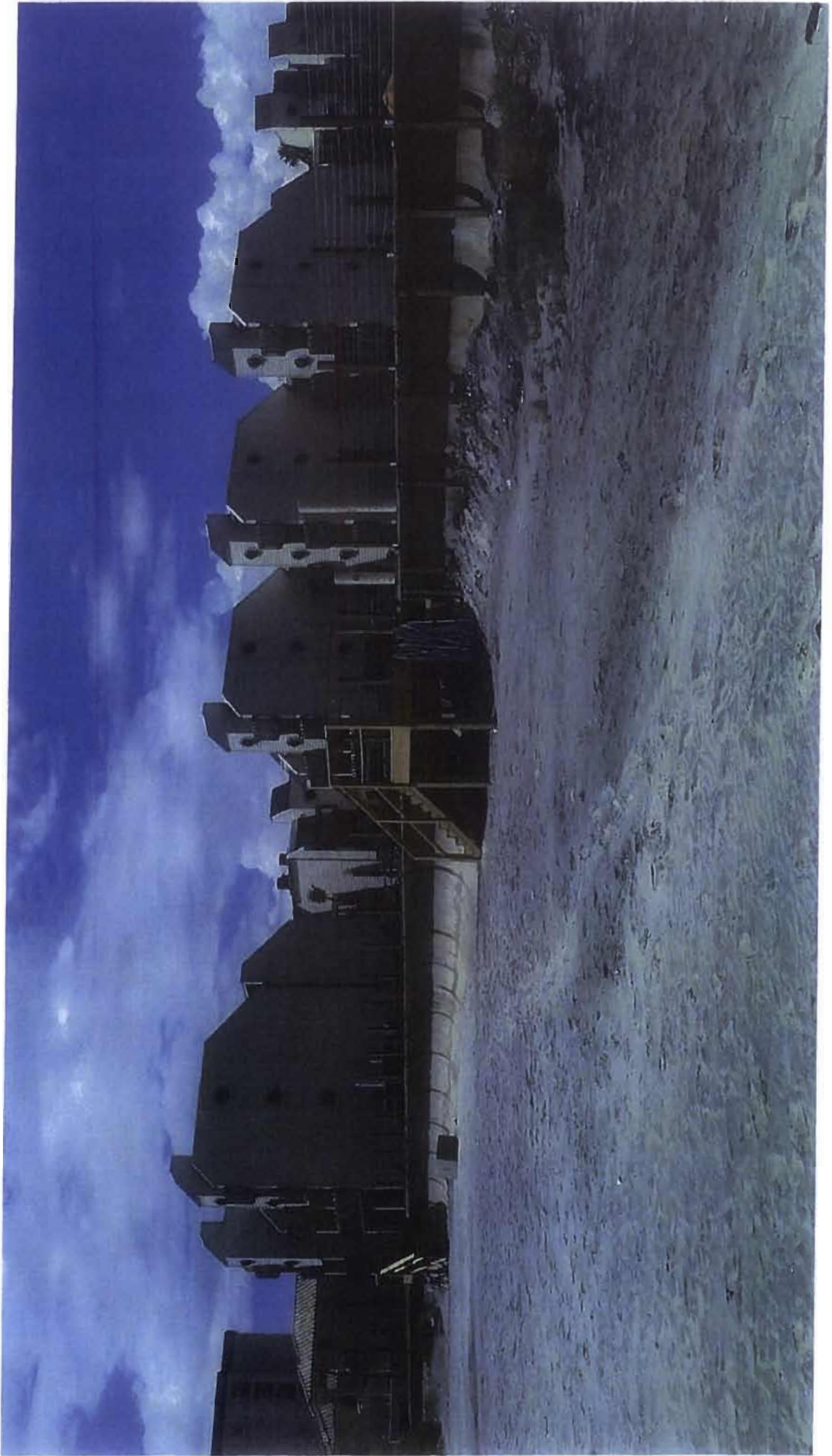

9-21

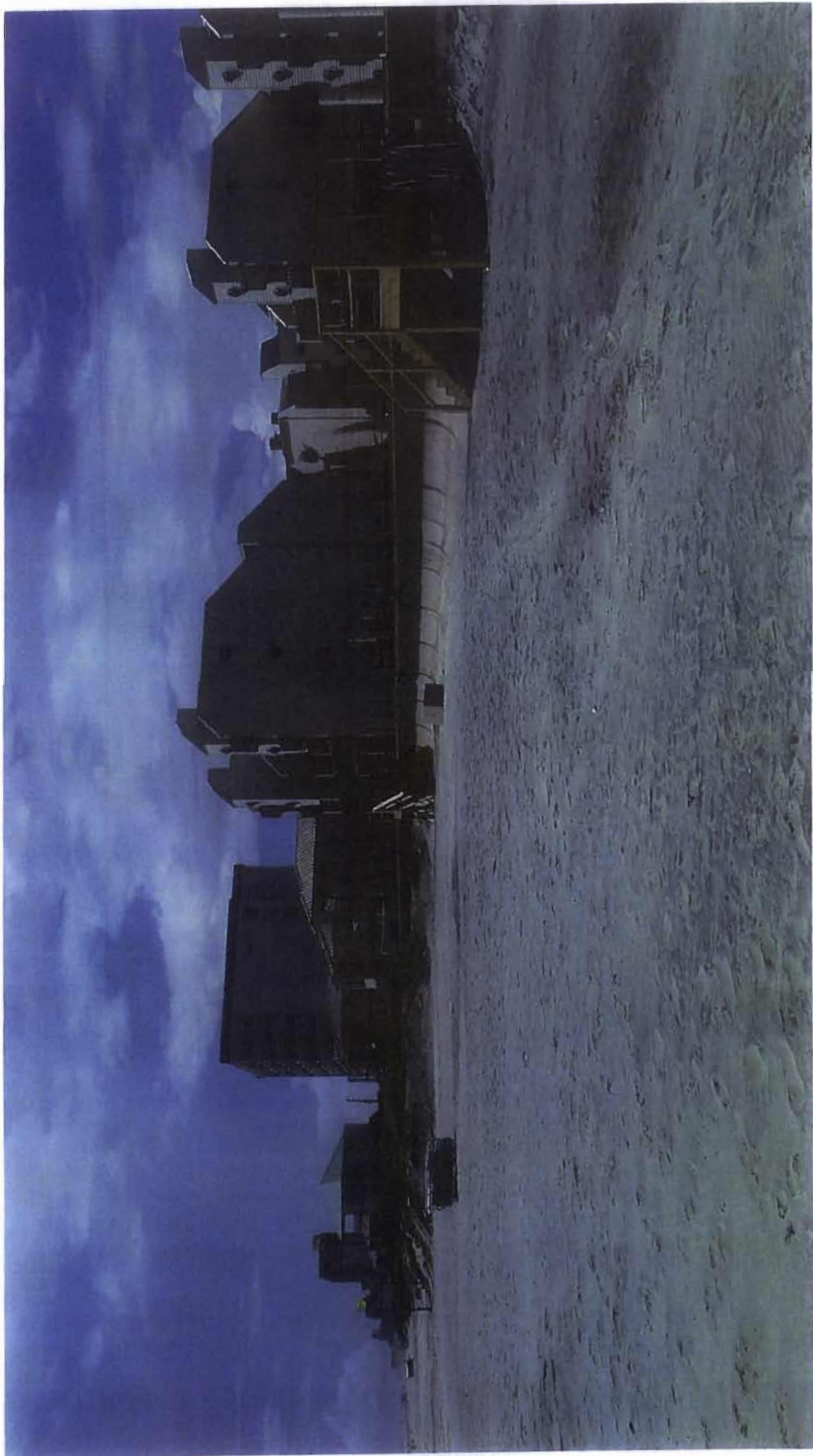

12-7

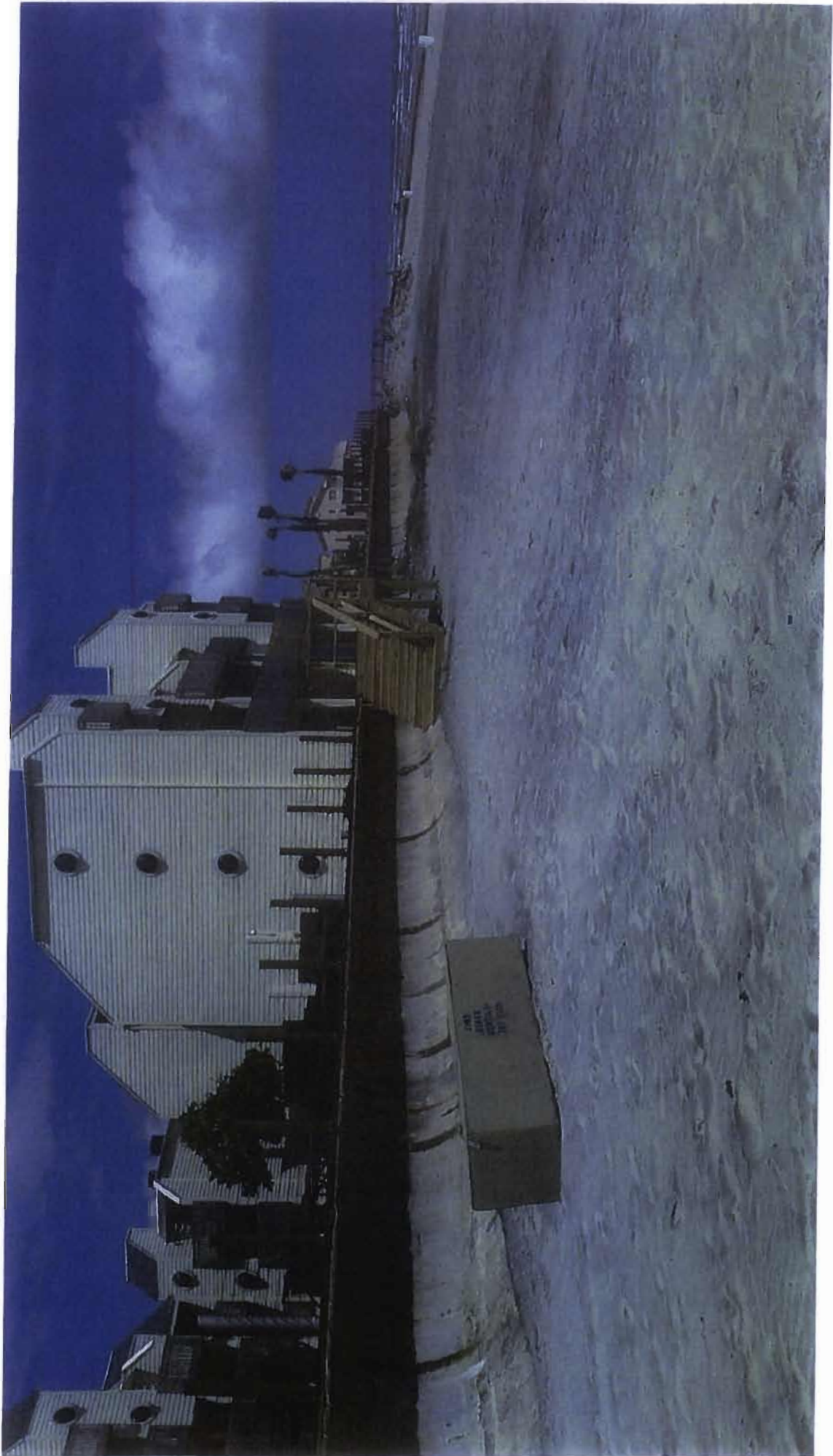

8-21

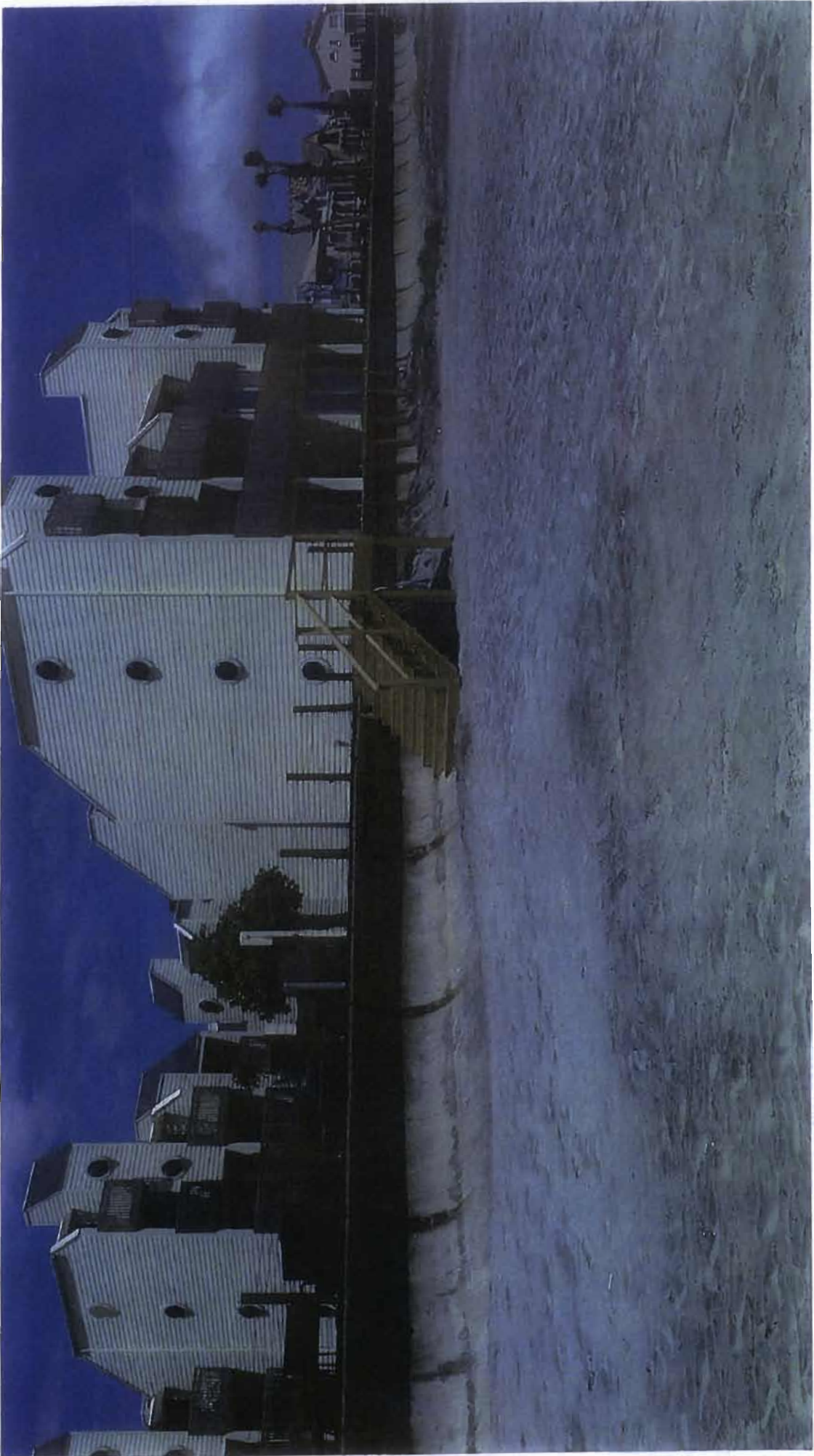

12-9

NOTE: WE CAN'T GO WIDER BY CODE.

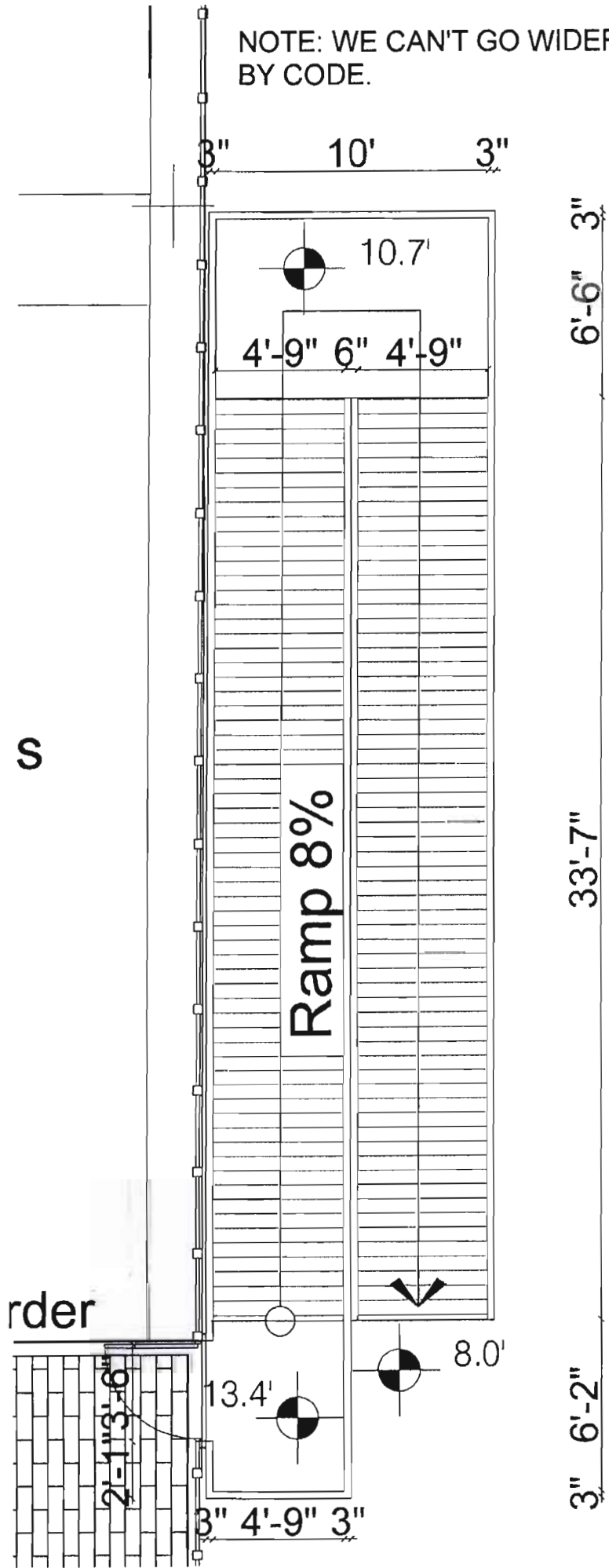

ramp plan

3/16"=1

12-11

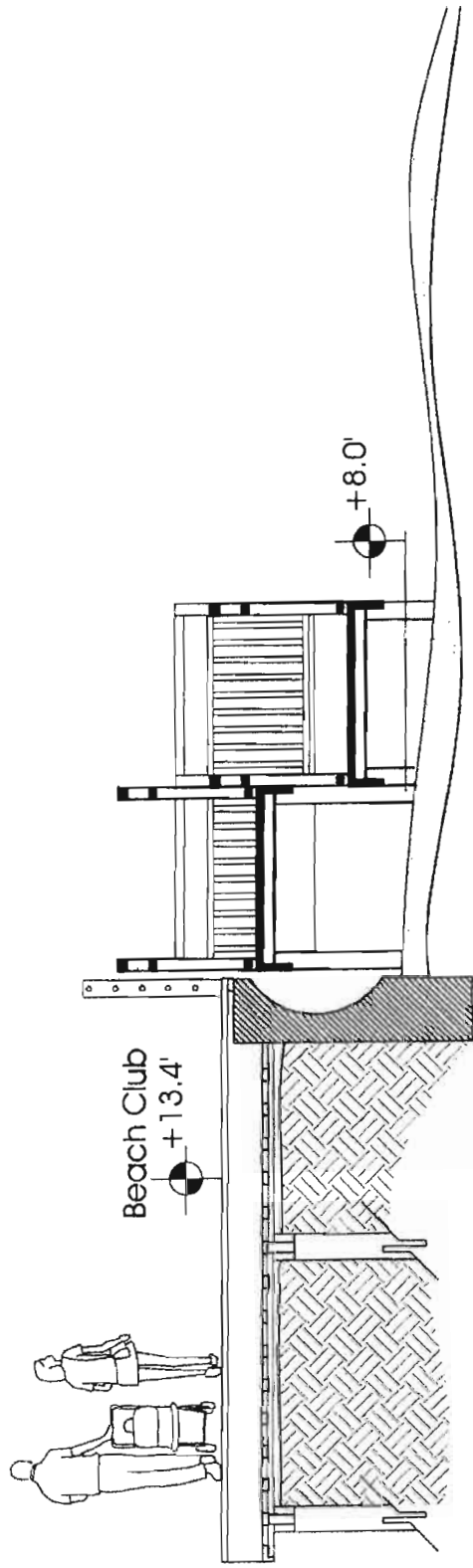

ramp section
3/16"=1'

21-21

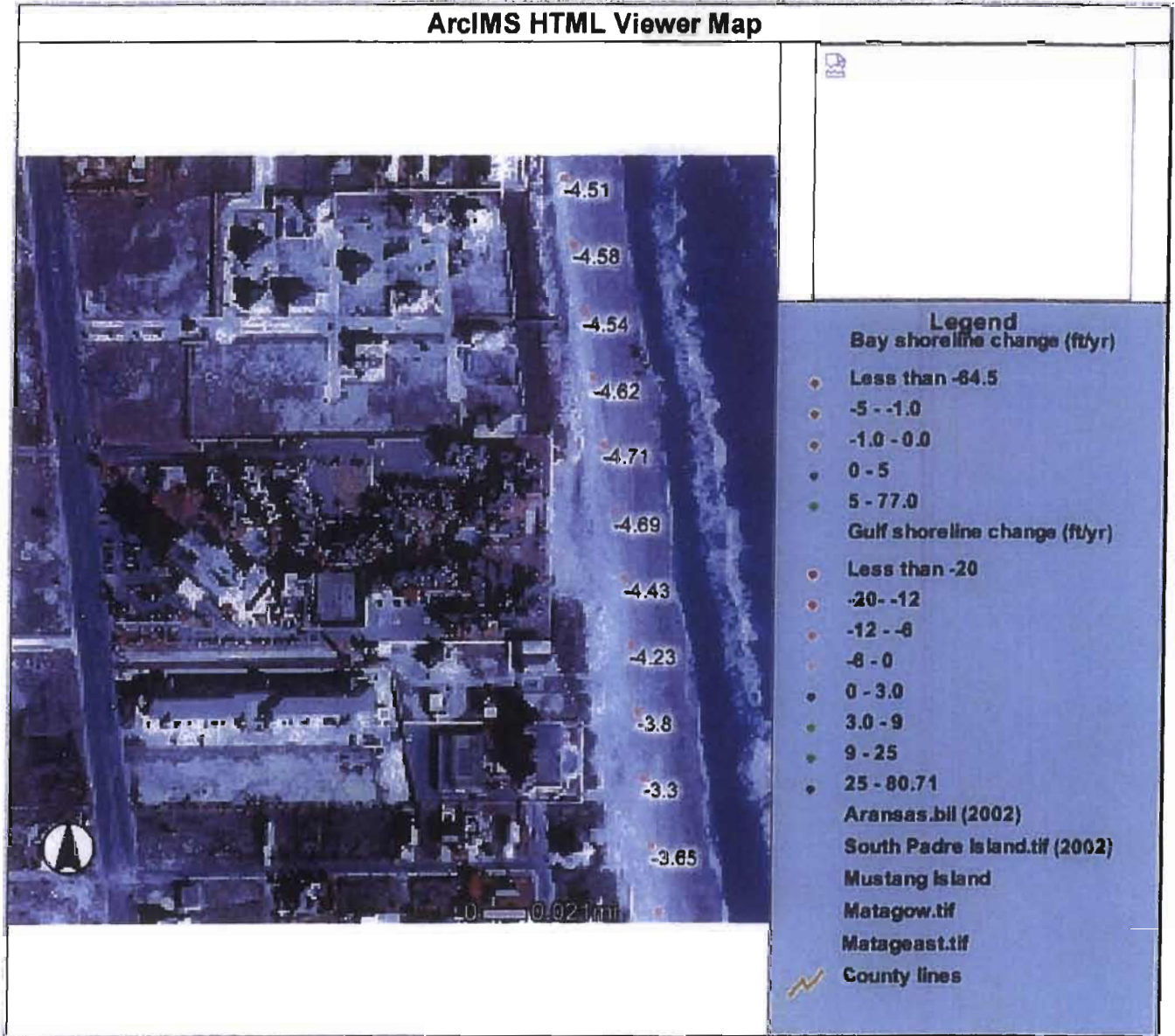

12-13

**SOUTH PADRE ISLAND
CITY COUNCIL MEETING
AGENDA REQUEST FORM**

MEETING DATE: October 6, 2010

NAME/DEPT.: Reuben Trevino, Coastal Resources Manager

ITEM

- A. Discussion and Action to give the City Manager authority to execute a contract with the GLO.

ITEM BACKGROUND

- A. The City submitted four grant applications last year to the CMP grant program. Originally this project was not selected for funding but funds have become available to move forward with the project. Gay Dawn circle is a completely undeveloped access located on the Northern portion of Gulf Blvd. Gay Dawn circle is located between Georgia Ruth and Verna Jean Drive. The development includes the addition of a parking lot with facilities and a walkover.

RECOMMENDATIONS/COMMENTS

Staff supports the approval of the contract.

BUDGET/FINANCIAL SUMMARY

The match for the grant has already been budgeted for next fiscal year.

COMPREHENSIVE PLAN GOAL

Chapter 4 – Parking Plan

Chapter 5 – Issue 1 – Protection and enhancement of the beach and dunes

5.1 Construct or reconstruct walkovers at all designated beach access points wide enough to allow pedestrians traveling in opposite directions. Simultaneously, construct directional barriers to prevent breached access to the dunes.

5.6 Establish or strengthen an ongoing, regular dune maintenance program. Continue to leverage access to State and Federal funds to continuously sustain this activity.

COUNCIL ACTION

Motion: _____

Second: _____

Vote: Ayes: _____ **Nays:** _____

Abstentions: _____

TEXAS



GENERAL LAND OFFICE

JERRY PATTERSON, COMMISSIONER

September 15, 2010

Ms. Joni Clarke, City Manager
City of South Padre Island
4601 Padre Blvd.
South Padre Island, Texas 78597

RE: General Land Office Contract No. 10-451-000-4453

Dear Ms. Clarke:

Enclosed are two partially executed original Contracts, as referenced above. Please have them properly executed by an official authorized to bind the city and return one to me for Land Office files.

If you have any questions, please do not hesitate to contact me at (512) 305-9129, or via electronic mail at mel.mcdonald@glo.state.tx.us.

Sincerely,

Melbourne T. McDonald Jr., Contract Specialist
Legal Services Division

MM/mm
Enclosures

Mel McDonald – Contract Specialist
Texas General Land Office
Legal Services Division – Mail Code 158
PO BOX 12873
Austin, TX 78711-2873

Or: 1700 N. Congress Ave. – Mail Code 158 / Austin, TX 78701

Stephen F. Austin Building • 1700 North Congress Avenue • Austin, Texas 78701-1495

Post Office Box 12873 • Austin, Texas 78711-2873

512-463-5001 • 800-998-4GLO

www.glo.state.tx.us

13-3



**SUBRECIPIENT GRANT AGREEMENT
GLO CONTRACT NO. 10-451-000-4453
COASTAL MANAGEMENT PROGRAM – CYCLE 13**

This subrecipient grant agreement (“Contract”) is entered into by and between the **GENERAL LAND OFFICE** (“GLO”), a State agency, and the **CITY OF SOUTH PADRE ISLAND** (“Subrecipient”).

Subrecipient has applied for Texas Coastal Management Program (“CMP”) Cycle 13 grant funds, to be made available to the State of Texas by the U.S. Department of Commerce, National Oceanic and Atmospheric Administration (“NOAA”), pursuant to the Federal Coastal Zone Management Act of 1972, 16 U.S.C. §1451, et seq., NOAA Award No. NA08NOS4190458 (the “Grant”). The Grant funds are limited to use for implementation of a coastal zone management project (the “Project”) under the CMP, administered by the GLO (as Coastal Zone Management Awards, CFDA #11.419) pursuant to Texas Natural Resources Code Ann. Sections 33.052 and 33.204, in coordination with the Coastal Coordination Council.

I. DEFINITIONS / INTERPRETIVE PROVISIONS

1.01 DEFINITIONS

“Administrative and Audit Regulations” means the statutes and regulations included in Title 43, Code of Federal Regulations; Chapter 321 of the Texas Government Code; Subchapter F of Chapter 2155 of the Texas Government Code; and the requirements of Article VIII herein. With regard to any federal funding, agencies with the necessary legal authority include: the relevant federal agency, the Comptroller General, the General Accounting Office, the Office of Inspector General, and any of their authorized representatives. In addition, state agencies with the necessary legal authority include, but are not limited to: the GLO, the GLO’s contracted examiners, the State Auditor’s Office, and the Texas Attorney General’s Office.

“Attachment” means documents, terms, conditions, or additional information physically added to this Contract following the execution page or included by reference, as if physically, within the body of this Contract.

“Contract” means this entire document, along with any Attachments, both physical and incorporated by reference.

“Deliverables” means any report, data, document, photograph, or other submission required to be delivered under the terms of this Contract, in whatever form.

13-4

“Equipment” is defined as tangible personal property having a useful life of more than one (1) year, and an acquisition cost of **FIVE THOUSAND DOLLARS (\$5,000.00)** or more per unit.

“Federal Assurances” means Standard Form 424B (Rev. 7-97), as prescribed by OMB Circular A-102 (non-construction projects); or Standard Form 424D (Rev. 7-97), as prescribed by OMB Circular A-102 (construction projects), in **Attachment F**, attached hereto and incorporated herein for all purposes.

“Federal Certifications” means U.S. Department of Commerce Form CD-512 (Rev 12-04), “Certifications Regarding Lobbying - Lower Tier Covered Transactions,” in **Attachment G**, attached hereto and incorporated herein for all purposes.

“Fiscal Year” means the period beginning September 1 and ending August 31 each year, which is the annual accounting period for the State of Texas.

“GASB” means the Governmental Accounting Standards Board.

“General Affirmations” means the affirmations in **Attachment I**, attached hereto and incorporated herein for all purposes, to which Subrecipient certifies by the signing of this Contract.

“GLO” means the Texas General Land Office, its officers, employees, and designees.

“Grants Administrator” means the GLO staff member responsible for administering this Grant, Melissa Porter, GLO Coastal Resources Division (512.475.1393 or melissa.porter@glo.state.tx.us), or her designee.

“HUB” means Historically Underutilized Business, as defined by Chapter 2161 of the Texas Government Code.

“Mentor Protégé” means the Comptroller of Public Accounts’ leadership program found at: <http://www.window.state.tx.us/procurement/prog/hub/mentorprotege/>

“Project” means the activities involved in “Gay Dawn Circle,” described in **Section 2.01** and detailed in the Work Plan in **Attachment A** of this Contract.

“Prompt Pay Act” means Chapter 2251, Subtitle F of Title 10 of the Texas Government Code.

“Public Information Act” means Chapter 552 of the Texas Government Code.

“State of Texas Textravel” means Texas Administrative Code, Title 34, Part 1, Chapter 5, Subchapter C, Section 5.22, relative to travel reimbursements under this Contract, if any.

13-5

“Subcontractor” means an individual or business that signs a contract to perform part or all of the obligations of Subrecipient under this Contract.

“Subrecipient” means the City of South Padre Island, selected to accomplish the Project under this Contract.

“Work Plan” means the methodology, means, and manner in which the Project shall be accomplished, as detailed in **Attachment A** of this Contract.

1.02 INTERPRETIVE PROVISIONS

- (a) The meanings of defined terms are equally applicable to the singular and plural forms of the defined terms.
- (b) The words “hereof,” “herein,” “hereunder,” and similar words refer to this Contract as a whole and not to any particular provision, section, attachment, work order, or schedule of this Contract unless otherwise specified.
- (c) The term “including” is not limiting and means “including without limitation” and, unless otherwise expressly provided in this Contract, (i) references to contracts (including this Contract) and other contractual instruments shall be deemed to include all subsequent amendments and other modifications thereto, but only to the extent that such amendments and other modifications are not prohibited by the terms of this Contract, and (ii) references to any statute or regulation are to be construed as including all statutory and regulatory provisions consolidating, amending, replacing, supplementing, or interpreting the statute or regulation.
- (d) The captions and headings of this Contract are for convenience of reference only and shall not affect the interpretation of this Contract.
- (e) All attachments within this Contract, including those incorporated by reference, and any amendments are considered part of the terms of this Contract.
- (f) This Contract may use several different limitations, regulations, or policies to regulate the same or similar matters. All such limitations, regulations, and policies are cumulative and each shall be performed in accordance with its terms.
- (g) Unless otherwise expressly provided, reference to any action of the GLO or by the GLO by way of consent, approval, or waiver shall be deemed modified by the phrase “in its/their sole discretion.” Notwithstanding the preceding sentence, any approval, consent, or waiver required by, or requested of, the GLO shall not be unreasonably withheld or delayed.
- (h) Time is of the essence in this Contract.

II. PROJECT REQUIREMENTS

2.01 WORK PLAN

The Project shall strictly conform to the work plan and special conditions contained in **Attachment A**, the Work Plan. Deliverables and due dates included in the Work Plan may be amended by the Grants Administrator upon submission of a written request and detailed justification by Subrecipient to the address listed and in the manner described in **Section 10.07** of this Contract.

2.02 PROGRESS REPORTS

Subrecipient shall submit monthly progress reports that must be received by the GLO on or before the 10th day of each month during the term of this Contract, commencing on the 10th day of the month immediately following the date the contract is fully executed ("Progress Reports"). Progress Reports must be submitted in Word or WordPerfect format via email to the Grants Administrator on the Progress Report form, a sample of which is attached hereto as **Attachment B**. The Progress Report form may be downloaded at:

<http://www.glo.state.tx.us/coastal/grants/subrecipient.html>

All Progress Reports shall include:

- (a) a brief statement of the overall progress of each task identified on the Work Plan since the last progress report;
- (b) a brief description of any problems that have been encountered during the previous reporting period that will affect the Work Plan, delay the completion of any portion of this Contract, or inhibit the completion of or cause a change in any of the Work Plan objectives;
- (c) a description of any action Subrecipient plans to undertake to correct any problems that have been encountered; and
- (d) a status report on the Budget, as defined in this Contract.

Any request for change of work and scope from the originally awarded project must be approved by both the Grants Administrator and NOAA, and may cause delays in the progress of the Project. All requests for changes must be submitted in writing, and must include justification of actions. Any costs incurred while waiting for approval of the requested changes are the responsibility of Subrecipient. The GLO will inform Subrecipient upon final approval or denial of the request for changes.

In addition, Subrecipient must submit a Project closeout form to the GLO Grants Administrator upon completion of the Project. The closeout form may be found at :

<http://www.glo.state.tx.us/coastal/grants/subrecipient.html>.

REMAINDER OF PAGE INTENTIONALLY LEFT BLANK

13-7

2.03 DELIVERABLES

Subrecipient shall deliver to the GLO two (2) complete paper copies, together with one (1) electronic copy, in portable document format (.pdf) on a compact disk, of each of the deliverables set forth in the Work Plan, in the time and manner prescribed therein. The GLO may require Subrecipient to conform any data presentation or products funded under this Contract to reflect GLO comments. Deliverable due date flexibility may be allowed by the GLO, to the extent that the revision to the deliverable due date does not extend past the term of the Contract.

2.04 GEOGRAPHIC INFORMATION SYSTEMS

Data, databases, and products associated with electronic Geographic Information Systems (GIS) that have been collected, manipulated, or purchased with CMP grant funds and/or local match funds will be subject to all applicable terms of the *Texas Geographic Information Standards* of the Texas Geographic Information Council (TGIC) and Texas Administrative Code (TAC) Section 201.6, Planning and Management of Information Resources Technologies, Geographic Information Standards. The Geographic Information Standards Rule is available on the World Wide Web at:

www.dir.state.tx.us/tgic/pubs/pubs.htm

or by writing to Department of Information Resources (DIR), PO Box 13564, Austin, TX, 78711, or via email to michael.ouimet@dir.state.tx.us.

2.05 TRANSFER OF DATA

Any GIS data to be transferred or exchanged that is collected, manipulated, or purchased with funds from this Contract MUST be documented as specified in the Federal Geographic Data Committee (FGDC) document *Content Standard for Digital Geospatial Metadata, version 2* (FGDC-STD-001-1998) or later. The federal metadata standard is available on the World Wide Web at:

www.fgdc.gov/metadata/csdgm.

Metadata must be submitted in HTML, XML or ASCII text formats.

2.06 FORMAT

Although many Texas state agencies, including the GLO, have adopted Environmental Systems Research Institute, Inc. (ESRI) software products as in-house GIS software, this is NOT an endorsement of these, or any other, products. However, any electronic spatial data collected, manipulated, or purchased with CMP grant funds and/or local match funds shall be transferred in a mutually-acceptable GIS format, along with corresponding metadata (see above). Non-spatial data deliverables (reports, tables, databases, spreadsheets, images) must be delivered in Acrobat PDF, MS Office, WordPerfect, dBase (.dbf), ASCII, or standard image formats (JPEG, TIFF, GIF, etc.). Acceptable media for delivery include CD-ROMs, DVDs, Zip disks, floppy disks, and external hard drives.

REMAINDER OF PAGE INTENTIONALLY LEFT BLANK

III. TERM

3.01 DURATION

This Contract shall be effective as of the date executed by the last party, and shall terminate upon completion of the Project or on June 30, 2011, whichever is earlier. Upon receipt of a written request and acceptable justification from Subrecipient, the GLO may extend this Contract for a period not to exceed three (3) months. **Any request for extension must be received by the GLO at least forty-five (45) days before the Contract's original termination date.**

3.02 EARLY TERMINATION

The GLO may terminate this Contract by giving written notice specifying a termination date at least thirty (30) days subsequent to the date of the notice. Upon receipt of any such notice, Subrecipient shall cease work, undertake to terminate any relevant subcontracts, and incur no further expense related to this Contract. Such early termination shall be subject to the equitable settlement of the respective interests of the parties, accrued up to the date of termination.

REMAINDER OF PAGE INTENTIONALLY LEFT BLANK

IV. GRANT FUNDS

4.01 CONTRACT LIMIT, FEES, AND EXPENSES

- (a) Subject to the Grant and the terms and conditions of this Contract, the GLO agrees to grant to Subrecipient an amount not to exceed **ONE HUNDRED SEVENTY-SEVEN THOUSAND SIX HUNDRED DOLLARS (\$177,600.00)**, payable in installments as reimbursement of allowable expenses incurred by Subrecipient in connection with Subrecipient's performance of the Project; and Subrecipient shall provide **ONE HUNDRED EIGHTEEN THOUSAND FOUR HUNDRED DOLLARS (\$118,400.00)** in matching funds, for a total amount not to exceed **TWO HUNDRED NINETY-SIX THOUSAND DOLLARS (\$296,000.00)** for the duration of the Contract.
- (b) Allowable expenses will be reimbursed to Subrecipient in accordance with the Budget included in **Attachment A**. The GLO will not provide reimbursement for any expenses not contained in the Budget; and is not liable to Subrecipient for any costs incurred by Subrecipient before the effective date of this Contract or after the termination or expiration of this Contract.
- (c) Further, it is expressly understood and agreed by Subrecipient that the GLO shall have the right to recapture and have reimbursed to the GLO any payments made by the GLO under this Contract that Subrecipient has not used in strict accordance with this Contract. **This recapture provision shall survive the termination or expiration of this Contract.**

REMAINDER OF PAGE INTENTIONALLY LEFT BLANK

V. REIMBURSEMENT / BUDGET / PURCHASES / RETAINAGE

5.01 REIMBURSEMENT REQUESTS

Each request for reimbursement shall:

- (a) prominently display "GLO Contract No. 10-451-000-4453," the failure of which may significantly delay payment under the Contract;
- (b) be on the approved GLO forms, samples of which are attached hereto as **Attachment C**. These forms may be downloaded at:
<http://www.glo.state.tx.us/coastal/grants/subrecipient.html>;
- (c) be supported by an invoice detailing each expense by Budget category in accordance with **Attachment A**;
- (d) include a timesheet or a payroll clearing account spreadsheet; and
- (e) provide such other information as the GLO may request.

Subrecipient may not charge "other operating costs" (i.e., administrative costs, computer usage fees, etc.) in addition to indirect costs, if such costs are already included in the calculation to determine Subrecipient's indirect cost rate.

Each invoice shall be supported by actual receipts, cancelled checks, and/or such other documentation that, in the judgment of the GLO, allows for full substantiation of the costs incurred. Requests for payment must be submitted in Word or WordPerfect format via email to the Grants Administrator monthly on or before the 10th day of each calendar month.

REQUESTS FOR REIMBURSEMENT UNDER THIS CONTRACT MUST BE RECEIVED BY THE GLO NOT LATER THAN SIXTY (60) DAYS FROM THE DATE SUBRECIPIENT INCURS THE EXPENSE. NOTWITHSTANDING THE PRECEDING, REQUESTS FOR REIMBURSEMENT FOR EXPENSES INCURRED BY ANY SUBCONTRACTOR MUST BE RECEIVED BY THE GLO NOT LATER THAN THIRTY (30) DAYS FROM THE DATE THE SUBRECIPIENT RECEIVES THAT INVOICE FROM A SUBCONTRACTOR. FAILURE BY SUBRECIPIENT TO COMPLY IN A TIMELY MANNER WITH THESE TWO REQUIREMENTS MAY, AT THE GLO'S SOLE DISCRETION, RESULT IN DENIAL OF THE REQUEST FOR REIMBURSEMENT.

5.02 BUDGET VARIANCE

Upon written request and justification by Subrecipient to the Grants Administrator, reallocation among budget categories may be allowed. Subrecipient must use the GLO Budget Amendment Form, a sample of which is attached hereto as **Attachment D**. This form may be downloaded at:

<http://www.glo.state.tx.us/coastal/grants/subrecipient.html>.

Such reallocations may not increase the amount of the grant or total Budget, and shall be effective only after approval by the GLO. Any request for a variance that changes the total

budget amount or the project scope or outcome may be allowed only through the formal, written Contract amendment process. **A FINAL, ACTUAL BUDGET, TO BE ATTACHED HERETO AS ATTACHMENT A-1, SHALL BE SUBSTITUTED FOR THE EXISTING BUDGET IN ATTACHMENT A, AND SHOULD BE SUBMITTED NO LATER THAN THIRTY (30) DAYS FROM THE EXPIRATION OR TERMINATION OF THE CONTRACT.**

5.03 PURCHASES

Subrecipient shall not purchase any equipment and/or computer software not included as a reimbursable Budget item in **Attachment A**. Title and possession of any Equipment will remain the property of Subrecipient unless and until transferred to the GLO, upon written request by the GLO, or termination or completion of the Contract. Subrecipient shall furnish, with its final request for reimbursement, a list of all Equipment purchased with NOAA financial assistance under this Contract. The disposition of any Equipment, as defined above, shall follow the Uniform Grants Management Standard Guidelines.

5.04 RETAINAGE

To ensure full performance, the GLO may retain an amount equal to thirty-three percent (33%) of the Subrecipient grant amount until Subrecipient's delivery, and GLO's approval, of all deliverables required herein. The GLO shall make a final disbursement only upon receipt of documentation sufficient to determine that Subrecipient has completed the project in accordance with the Work Plan and that all requirements of this Contract and the relevant provisions of the Grant have been fulfilled by Subrecipient, including, but not limited to, match documentation requirements, if any.

REMAINDER OF PAGE INTENTIONALLY LEFT BLANK

VI. STATE FUNDING

6.01 STATE FUNDING

This Contract shall not be construed as creating any debt on behalf of the State of Texas and/or the GLO in violation of Texas Constitution, Article III, Section 49. In compliance with Texas Constitution, Article VIII, Section 6, it is understood that all obligations of the GLO hereunder are subject to the availability of state funds. If such funds are not appropriated or become unavailable, this Contract may be terminated. In that event, the parties shall be discharged from further obligations, subject to the equitable settlement of their respective interests, accrued up to the date of termination.

REMAINDER OF PAGE INTENTIONALLY LEFT BLANK

VII. COPYRIGHT / PUBLICATION

7.01 COPYRIGHT

The parties expressly agree that the GLO shall own all right, title, and interest in and to any copyright or other intellectual property rights in any material or information developed under this Contract including the right to use, reproduce, or publish any or all of such information and other materials without the necessity of obtaining permission from Subrecipient, and without expense or charge. Subrecipient shall not assert any legal rights or otherwise seek to establish any claim to statutory copyright in any material or information developed under this Contract. **THIS PROVISION SHALL SURVIVE THE TERMINATION OR EXPIRATION OF THIS CONTRACT.**

7.02 PUBLICATION

- (a) If Subrecipient or its employee(s) use NOAA financial assistance to publish reports and other materials completed as a result of this Contract, the author shall assure that the paper bears the following statement as well as the NOAA and CMP logos on the front cover or title page of such document and other materials:

A PUBLICATION (OR REPORT) OF THE COASTAL COORDINATION COUNCIL PURSUANT TO NATIONAL OCEANIC AND ATMOSPHERIC ADMINISTRATION AWARD NO. NA08NOS4190458.

- (b) If Subrecipient or its employee(s) use NOAA financial assistance to publish a paper based in whole or in part on the work funded by this Contract, the author shall assure that the paper bears the following statement as well as the NOAA and CMP logos on the front cover or title page of the paper:

THIS PAPER IS FUNDED ("IN PART" IF APPROPRIATE) BY A GRANT/COOPERATIVE AGREEMENT FROM THE NATIONAL OCEANIC AND ATMOSPHERIC ADMINISTRATION. THE VIEWS EXPRESSED HEREIN ARE THOSE OF THE AUTHOR(S) AND DO NOT NECESSARILY REFLECT THE VIEWS OF NOAA OR ANY OF ITS SUB-AGENCIES.

- (c) If the Subrecipient or its employee(s) use NOAA financial assistance to produce signage, the Subrecipient shall assure that the signage bears the following statement as well as the NOAA and CMP logos on all signs:

THIS PROJECT IS FUNDED ("IN PART" IF APPROPRIATE) BY A GRANT FROM THE COASTAL COORDINATION COUNCIL PURSUANT TO NATIONAL OCEANIC AND ATMOSPHERIC ADMINISTRATION AWARD NO. NA08NOS4190458.

- (d) When issuing statements, press releases, requests for proposals, bid solicitations, and other documents describing projects or programs funded in whole or in part with federal funds, including, but not limited to, state and local governments and recipients of federal research grants, the Subrecipient shall clearly state (i) the percentage of the total costs of the project or program which will be financed with

federal money; (ii) the dollar amount of federal funds for the project of program; and (iii) percentage and dollar amount of the total costs of the project or program that will be financed by nongovernmental sources. **ALL DOCUMENTS AND MATERIALS MUST CONTAIN THE NOAA AND CMP LOGOS ON THE FRONT OR TITLE PAGE.**

- (e) **THIS PROVISION SHALL SURVIVE THE TERMINATION OR EXPIRATION OF THIS CONTRACT.**

REMAINDER OF PAGE INTENTIONALLY LEFT BLANK

13-15

VIII. RECORDS / ADMINISTRATIVE AND AUDIT / RETENTION / PUBLIC RECORDS

8.01 BOOKS AND RECORDS

Subrecipient shall keep and maintain full, true, and complete records in accordance with GAAP necessary to fully disclose to the GLO, the Texas State Auditor's Office, the United States Government, and/or their authorized representatives sufficient information to determine compliance with the terms and conditions of this Contract and all state and federal rules, regulations, and statutes.

8.02 ADMINISTRATIVE AND AUDIT REGULATIONS

- (a) The GLO, as a pass-through entity, has the responsibility to ensure that Subrecipients expending **FIVE HUNDRED THOUSAND DOLLARS (\$500,000.00)** or more in federal awards during each of the Subrecipient's fiscal years of funding have met audit requirements in accordance with U.S. Office of Management and Budget Circular A-133. Subrecipient shall complete and return the Audit Reporting Form, attached hereto as **Attachment E**, no later than September 1 of each year until the Contract is terminated. **Attachment E** may be downloaded at:

<http://www.glo.state.tx.us/coastal/grants/subrecipient.html>.

- (b) In addition, Subrecipient agrees that all relevant records related to this Contract and any Deliverables produced in relation to this Contract, including the records and Deliverables of its Subcontractors, shall be subject to the Administrative and Audit Regulations. Accordingly, such records and Deliverables shall be subject, at any time, to inspection, examination, audit, and copying at any location where such records and Deliverables may be found, with or without notice from the GLO or other government entity with necessary legal authority. Subrecipient agrees to cooperate fully with any federal or state entity in the conduct of inspection, examination, audit, and copying, including providing all information requested. Subrecipient will ensure that this clause concerning federal and state entities' authority to inspect, examine, audit, and copy records and Deliverables, and the requirement to fully cooperate with the federal and state entities, is included in any subcontract it awards.
- (c) Subrecipient understands that acceptance of state funds under this Contract acts as acceptance of the authority of the State Auditor's Office to conduct an audit or investigation in connection with those funds. Subrecipient further agrees to cooperate fully with the State Auditor's Office in the conduct of the audit or investigation, including providing all records requested. Subrecipient will ensure that this clause concerning the State Auditor's Office's authority to audit state funds and the requirement to fully cooperate with the State Auditor's Office is included in any subcontracts it awards. Additionally, the State Auditor's Office shall at any time have access to and the rights to examine, audit, excerpt, and transcribe any pertinent books, documents, working papers, and records of Subrecipient relating to the Contract for any purpose.

8.03 PERIOD OF RETENTION

Subrecipient shall retain all records relevant to this Contract for a minimum of four (4) years. If any federal funds are used in the Contract, Subrecipient shall retain said records for a minimum of five (5) years. The period of retention begins at the date of payment by the GLO for the goods or services or from the date of termination of the Contract, whichever is later. The period of retention shall be extended for a period reasonably necessary to complete an audit and/or to complete any administrative proceeding or litigation that may ensue.

8.04 PUBLIC RECORDS

Pursuant to the Public Information Act, records received from Subrecipient may be open to public inspection and copying. The GLO will have the duty to disclose such records, unless a particular record is made confidential by law or excepted from the Act. Subrecipient may clearly label any individual records as a "trade secret," provided that Subrecipient thereby agrees to indemnify and defend the GLO for honoring such designation. The failure to so label any record shall constitute a complete waiver of any and all claims for damages caused by release of the records. If a request for a labeled record is received by the GLO, the GLO will notify Subrecipient of the request in accordance with the Public Information Act.

REMAINDER OF PAGE INTENTIONALLY LEFT BLANK

13-17

IX. EVENTS OF DEFAULT AND REMEDIES

9.01 EVENTS

Each of the following shall constitute an event of default ("Event of Default") under this Contract:

- (a) Subrecipient's failure to comply with any term, covenant, or provision contained in this Contract;
- (b) Subrecipient makes an assignment for the benefit of creditors or takes any similar action for the protection or benefit of creditors; or
- (c) If at any time, Subrecipient makes any representation or warranty that is incorrect in any material respect to: (i) the Work Plan; (ii) any request for payment submitted to the GLO; or (iii) any report submitted to the GLO related to the Contract.

9.02 REMEDIES; NO WAIVER

Upon the occurrence of any such Event of Default, the GLO shall be entitled to avail itself of any legal remedy. A right or remedy conferred by this Contract upon either Party is not intended to be exclusive of any other right or remedy, and each and every right and remedy shall be cumulative and in addition to any other right or remedy given under this Contract, or hereafter legally existing upon the occurrence of an Event of Default. The failure of the GLO either to insist at any time upon the strict observance or performance of any of the provisions of this Contract, or to exercise any right or remedy as provided in this Contract, shall not impair any such right or remedy or be construed as a waiver or relinquishment thereof with respect to subsequent defaults.

REMAINDER OF PAGE INTENTIONALLY LEFT BLANK

X. MISCELLANEOUS PROVISIONS

10.01 LEGAL OBLIGATIONS

Subrecipient shall procure and maintain for the duration of this Contract any state, county, city, or federal license, authorization, insurance, waiver, permit, qualification or certification required by statute, ordinance, law, or regulation to be held by Subrecipient to provide the goods or services required by this Contract. Subrecipient will be responsible for payment of all taxes, assessments, fees, premiums, permits, and licenses required by law. Subrecipient agrees to be responsible for payment of any such government obligations not paid by its Subcontractors during performance of this Contract. Subrecipient shall not commence construction of the Project until it has obtained the requisite licenses and/or permits. **COPIES OF SUCH LICENSES AND PERMITS SHALL BE INCLUDED AS A PART OF THE PROGRESS REPORT, AS DEFINED IN THIS CONTRACT, FOR THE PERIOD DURING WHICH THEY ARE OBTAINED.**

10.02 INDEMNITY

SUBRECIPIENT AGREES TO INDEMNIFY AND HOLD THE GLO HARMLESS, TO THE FULL EXTENT PERMITTED UNDER THE CONSTITUTION AND LAWS OF THE STATE OF TEXAS, FROM AND AGAINST ANY AND ALL CLAIMS, DEMANDS, AND CAUSES OF ACTION ARISING FROM THE NEGLIGENT ACTS OR OMISSIONS OF SUBRECIPIENT, ITS EMPLOYEES OR AGENTS IN CONNECTION WITH THE PERFORMANCE OF SERVICES OR WORK BY SUBRECIPIENT OR ITS SUBCONTRACTORS UNDER THIS CONTRACT. THE PROVISIONS OF THIS SECTION 10.02 SHALL SURVIVE TERMINATION OF THIS CONTRACT. THIS SECTION 10.02 SHALL NOT BE CONSTRUED AS VIOLATING THE PROVISIONS OF ARTICLE III, SECTION 52 OF THE TEXAS CONSTITUTION.

10.03 ASSIGNMENT AND SUBCONTRACTS

Subrecipient shall not assign, transfer, or delegate any rights, obligations, or duties under this Contract not encompassed within the Work Plan without the prior written consent of the GLO. Notwithstanding this provision, it is mutually understood and agreed that Subrecipient may subcontract with others for some or all of the services or work to be performed. In any approved subcontracts, Subrecipient shall legally bind any such Subcontractors to perform and make such Subcontractors subject to all the duties, requirements, and obligations of Subrecipient specified herein. Nothing in this Contract shall be construed to relieve Subrecipient of the responsibility for ensuring that the goods delivered and/or the services rendered by Subrecipient and/or any of its Subcontractors comply with all the terms and provisions of this Contract. Subrecipient will provide written notification to the GLO of any such Subcontractor performing fifteen percent (15%) or more of the work under this Contract, including the name and taxpayer identification number of Subcontractor, the task(s) being performed, and the number of Subcontractor employees expected to work on the task.

10.04 HISTORICALLY UNDERUTILIZED BUSINESSES (HUBS)

- (a) In accordance with State law, it is the GLO's policy to assist HUBs whenever possible, to participate in providing goods and services to the agency. The GLO

encourages those parties with whom it contracts for the provision of goods and services to adhere to this same philosophy in selecting Subcontractors to assist in fulfilling Subrecipient's obligations with the GLO. In addition to information required by this Contract, Subrecipient will provide the Purchasing Department of the GLO with pertinent details of any participation by a HUB in fulfilling the duties and obligations arising hereunder.

- (b) The GLO encourages Subrecipients to partner with certified HUBs that participate in the Comptroller's Mentor Protégé Program. For more information on the program, and how it can assist your firm in meeting good faith effort goals please visit:

[http://www.window.state.tx.us/procurement/prog/hub/mentorprotege/.](http://www.window.state.tx.us/procurement/prog/hub/mentorprotege/)

- (c) Subrecipient shall, not later than March 1 of each year until termination of the Contract, complete and return the HUB expense report, attached hereto as **Attachment H**. **Attachment H** may also be downloaded at:

<http://www.glo.state.tx.us/coastal/grants/subrecipient.html>.

10.05 RELATIONSHIP OF THE PARTIES

Subrecipient is associated with the GLO only for the purposes and to the extent specified in this Contract, and, in respect to Subrecipient's performance pursuant to this Contract, Subrecipient shall have the sole right to supervise, manage, operate, control, and direct performance of the details incident to its duties under this Contract. Nothing contained in this Contract shall be deemed or construed to create a partnership or joint venture, to create relationships of an employer-employee or principal-agent, or to otherwise create for the GLO any liability whatsoever with respect to the indebtedness, liabilities, and obligations of Subrecipient or any other party.

10.06 COMPLIANCE WITH OTHER LAWS

In the performance of this Contract, Subrecipient shall comply with all applicable federal, state, and local laws, ordinances, and regulations. Subrecipient shall make itself familiar with and at all times shall observe and comply with all federal, state, and local laws, ordinances, and regulations that in any manner affect performance under this Contract.

10.07 NOTICES

Any notices required under this Contract shall be deemed delivered when deposited either in the United States mail, postage paid, certified, return receipt requested; or with a common carrier, overnight, signature required, to the appropriate address below:

GLO

Texas General Land Office
1700 N. Congress Avenue, Room 910
Austin, TX 78701
Attention: Legal Services Division

Subrecipient

City of South Padre Island
4601 Padre Blvd.
South Padre Island, TX 78597
Attention: Ms. Joni Clarke, City Manager

Notice given in any other manner shall be deemed effective only if and when received by the party to be notified. Either party may change its address for notice by written notice to the other party as herein provided.

10.08 GOVERNING LAW AND VENUE

This Contract and the rights and obligations of the parties hereto shall be governed by, and construed according to, the laws of the State of Texas, exclusive of conflicts of law provisions. Venue of any suit brought under this Contract shall be in a court of competent jurisdiction in Travis County, Texas. Subrecipient irrevocably waives any objection, including any objection to personal jurisdiction or the laying of venue or based on the grounds of forum non conveniens, which it may now or hereafter have to the bringing of any action or proceeding in such jurisdiction in respect of this Contract or any document related hereto. **NOTHING IN THIS SECTION SHALL BE CONSTRUED AS A WAIVER OF SOVEREIGN IMMUNITY BY THE GLO.**

10.09 SEVERABILITY

If any provision contained in this Contract is held to be unenforceable by a court of law, this Contract shall be construed as if such provision did not exist and the non-enforceability of such provision shall not be held to render any other provision or provisions of this Contract unenforceable.

10.10 DISPUTE RESOLUTION

If a Contract dispute arises that cannot be resolved to the satisfaction of the parties, either party may notify the other party in writing of the dispute. If the parties are unable to satisfactorily resolve the dispute within fourteen (14) days of the written notification, the parties must use the dispute resolution process provided for in Chapter 2260 of the Texas Government Code to attempt to resolve the dispute. This provision shall not apply to any matter with respect to which either party may make a decision within its respective sole discretion.

10.11 ASSURANCES AND AFFIRMATIONS

Subrecipient shall complete and return the Assurances-Construction/Non-Construction Programs form, attached hereto as **Attachment F**, assuring that it will comply with all federal statutes listed thereon and, when applicable, shall obtain and return completed assurance of compliance forms from its Subcontractors.

10.12 DEBARMENT

Subrecipient certifies that neither it nor its principals are presently debarred, suspended, proposed for debarment, declared ineligible, or voluntarily excluded from participation in this Contract by any state or federal department or agency. Prior to engaging any

13-21

contractor or Subcontractor, Subrecipient shall verify the contractor's or Subcontractor's eligibility for receiving state or federal funds, using (1) the Texas Comptroller of Public Accounts' Vendor Performance Program available on the Internet at:

http://www.window.state.tx.us/procurement/prog/vendor_performance/

for suspended and debarred vendors, and (2) the Federal General Services Administration's Excluded Parties List available on the Internet at:

<http://www.epls.gov/>

in compliance with Executive Order 12549, "Debarment and Suspension;" and 15 C.F.R. Part 26, Subparts A through E, "Governmentwide Debarment and Suspension."

10.13 LOBBYING

Subrecipient shall complete and return the Certification Regarding Lobbying, attached hereto as **Attachment G, Page 1**, certifying that no federal funds have been or will be paid to any person for influencing or attempting to influence any party named therein, and that if any non-federal funds have been paid for such purposes, Subrecipient shall complete and submit Standard Form-LLL, "Disclosure Form to Report Lobbying," attached hereto as **Attachment G, Page 2**.

10.14 CMP CONSISTENCY

Subrecipient shall complete the requirements of this Contract in compliance with the CMP goals and policies and shall assure that the performance of all Subcontractors is in compliance with the CMP.

10.15 PROPER AUTHORITY

Each party hereto represents and warrants that the person executing this Contract on its behalf has full power and authority to enter into this Contract. Subrecipient acknowledges that this Contract is effective for the period of time specified in the Contract. Any services performed by Subrecipient before this Contract is effective or after it ceases to be effective are performed at the sole risk of Subrecipient.

10.16 COUNTERPARTS

This Contract may be executed in any number of counterparts, each of which shall be an original, and all such counterparts shall together constitute but one and the same Contract. If the Contract is not executed by the GLO within thirty (30) days of execution by the other party, this Contract shall be null and void.

10.17 ENTIRE CONTRACT AND MODIFICATIONS

This Contract, its integrated attachment(s), and any purchase order issued in conjunction with this Contract constitute the entire agreement of the parties and are intended as a complete and exclusive statement of the promises, representations, negotiations, discussions, and other agreements that may have been made in connection with the subject

13-22

matter hereof. Any additional or conflicting terms in such attachment(s) and/or purchase order shall be harmonized with this Contract to the extent possible. Unless such integrated attachment or purchase order specifically displays a mutual intent to amend a particular part of this Contract, general conflicts in language shall be construed consistently with the terms of this Contract.

SIGNATURE PAGE FOLLOWS

SIGNATURE PAGE FOR GLO CONTRACT No. 10-451-000-4453

GENERAL LAND OFFICE

CITY OF SOUTH PADRE ISLAND



Larry L. Laine, Chief Clerk/
Deputy Land Commissioner

Date of execution: 7/14/14

By: _____
Title: _____

Date of execution: _____

 S.A.
Div.
A.G.C.
G.C.



ATTACHMENTS FOR GLO CONTRACT NO. 10-451-000-4453

ATTACHMENT A	WORK PLAN AND BUDGET
ATTACHMENT A-1	FINAL, ACTUAL BUDGET (TO BE SUBMITTED)
ATTACHMENT B	PROGRESS REPORT FORM¹
ATTACHMENT C	INVOICE FOR FEDERAL EXPENDITURES, MONTHLY GRANT PROJECT EQUIPMENT SHEET, AND MONTHLY GRANT PROJECT TIMESHEET
ATTACHMENT D	BUDGET AMENDMENT FORM
ATTACHMENT E	AUDIT REPORTING FORM
ATTACHMENT F	ASSURANCES – CONSTRUCTION / NON-CONSTRUCTION PROGRAMS
ATTACHMENT G	CERTIFICATIONS REGARDING LOBBYING
ATTACHMENT H	HISTORICALLY UNDERUTILIZED BUSINESSES (HUB) EXPENSE REPORT FORM
ATTACHMENT I	GENERAL AFFIRMATIONS

¹ Forms, which may be updated from time to time, may be downloaded at:
<http://www.glo.state.tx.us/coastal/grants/subrecipient.html>

Attachment A - Work Plan and Budget

Contract Number: 10-451-000-4453

Project Name: Gay Dawn Circle

Entity: City of South Padre Island

Project Description:

The City of South Padre Island (SPI), located on the southernmost end of Padre Island, is home to an estimated 5,000 inhabitants and according to the Visitor's and Convention Bureau, over five (5) million visitors. SPI has approximately 1/2 mile of Gulf of Mexico beach within Cameron County extending from one (1) to five and a half (5.5) miles north of the Brazos Santiago Pass north jetty. SPI experiences variable erosion rates, with an increasing erosion rate of Gulf shoreline three (3) to five and a half (5.5) miles north of the jetties, averaging six (6) feet per year (or 5-10ft/yr by the UTBEG Historical Erosion rate map).

Of the over five million persons visiting South Padre Island each year, a large majority are either day trippers or persons residing off the beach. The City's public beach access points enhance the local economy of the Island in addition to enriching the lives of people. Natural Resources Code, Title 2, Chapter 61, subchapter B indicates the need for a "public entity to provide at least one parking space for each 15 linear feet of beach restricted to vehicular access. The City, through public beach access points seeks to improve and create parking for residents and tourists. Quality parking is a must along the City beach access points as are improvements at dedicated points. In addition, the beach access plan requires that the city will provide head-in parking at Gay Dawn Circle.

The City seeks to improve Gay Dawn Circle (Access Point #20), which is a completely undeveloped access located on the northern end of Gulf Boulevard. Currently a mobi-mat provides a walk through for dune protection at this access point. The City's Beach and Dune Task Force recommendations for priority projects include: 3) Gay Dawn Circle - This access is a high traffic area on the north end of Gulf Boulevard. This public access has a healthy dune system but there there is no walkover to protect the dunes. An ADA walkover would be instrumental to keeping the dunes in this portion of the system strong and free of weak points leading to gaps and washovers.

The development of Gay Dawn Circle will include the following:

Parking Area - 10 spaces with one ADA accessible spot.

Sidewalk and Lighting

Irrigation and Landscaping

Foot Showers, Bathroom, and Drinking Water

Dune Walk-Over

Public access signage designating parking spots are for public beach access only

Attachment A - Work Plan and Budget

Project Budget:

	CMP	Subrecipient	Third Party	Project Total
Salaries	\$0.00	\$0.00	\$0.00	\$0.00
Fringe	\$0.00	\$0.00	\$0.00	\$0.00
Travel	\$0.00	\$0.00	\$0.00	\$0.00
Supplies	\$0.00	\$0.00	\$0.00	\$0.00
Equipment	\$0.00	\$0.00	\$0.00	\$0.00
Contractual	\$177,600.00	\$118,400.00	\$0.00	\$296,000.00
Other	\$0.00	\$0.00	\$0.00	\$0.00
Subtotal:	\$177,600.00	\$118,400.00	\$0.00	\$296,000.00
Indirect	\$0.00	\$0.00	\$0.00	\$0.00
Total:	\$177,600.00	\$118,400.00	\$0.00	\$296,000.00

Special Award Conditions:

1. This project must be completed as described in this work plan. The GLO and/or NOAA must approve any changes in the scope of work or budget requests that change the total project cost. 2. In the event that the GLO and NOAA determine that the project or property is no longer used for its original purpose, the recipient shall reimburse NOAA for the federal funds received for the project.

Task 1 Description:

The City of South Padre Island will apply for a Beach and Dune Protection Permit for construction at the beach access point to include parking, walkover, and water amenities in an area east of the right of way of Gulf Boulevard, and landward of the Historic Building Line. There will be a formal review and approval by the GLO, Beach and Dune Taskforce, and the City Council.

Deliverable(s)/Milestone(s):

Beach and Dune Permit

Deliverable Due Date(s): 10/31/2010

Task 2 Description:

Bidding of the process to include engineering and construction. The bidding process consists of writing and advertising a Request for Proposals (RFP). The City staff

13-27

Attachment A - Work Plan and Budget

ensures this process meets all standards of the City and the State of Texas. The Bid opening date will depend on the amount of the bid request and approval by the City Council. The Engineering of the site will be outlined and approved by the City.

Deliverable(s)/Milestone(s):

1. Copy of Engineering Contract
2. Draft & Final Engineering Drawings
3. Draft & Final Construction Bid Package

Deliverable Due Date(s): 1/31/2011

Task 3 Description:

Installation of water lines requiring a partnership with the Laguna Madre Water District to meet required specifications.

Deliverable(s)/Milestone(s):

Copy of Necessary Permits

Deliverable Due Date(s): 1/31/2011

Task 4 Description:

The City will hire contractors for installation of approved engineering design. This project will be overseen by the City's Coastal Resources Manager and the City's Public Works Assistant Director.

Deliverable(s)/Milestone(s):

1. Construction Contract
2. Draft & Final Text on Signage Designating Parking Spots are for Public Beach Access Only
3. Certificate of Completion including TDLR Certificate
4. Photos of Completed Project

Deliverable Due Date(s): 6/30/2011

13-28

PROGRESS REPORT

(Project Name)

(GLO Contract No.)

(Reporting Period)

Task 1: (Name of task as identified in Attachment A of your contract)

- Status of the task during this reporting period: in progress completed
- Briefly describe major accomplishments for this reporting period.

- List the deliverable(s)/milestone(s) completed during this reporting period. (Submit a copy of your completed deliverable(s)/milestone(s) with this report.)

- Were there any problems or obstacles encountered during this reporting period (e.g., delays, remedial action taken, schedule revision). Yes No If yes, please explain:

- Briefly describe plans for the next reporting period.

(Repeat for each task, if necessary. If work on a particular task has not begun or has been completed, do not include in progress report.)

Please provide a current budget breakdown. (Double Click on budget tables to activate Excel.)

	Current Federal/ CMP Budget	Billed to Date	Obligated* CMP Budget	Remaining CMP Budget
Personnel	\$ -	\$ -	\$ -	\$ -
Fringe	\$ -	\$ -	\$ -	\$ -
Travel	\$ -	\$ -	\$ -	\$ -
Supplies	\$ -	\$ -	\$ -	\$ -
Equipment	\$ -	\$ -	\$ -	\$ -
Contractual	\$ -	\$ -	\$ -	\$ -
Other	\$ -	\$ -	\$ -	\$ -
Subtotal	\$ -	\$ -	\$ -	\$ -
Indirect Costs	\$ -	\$ -	\$ -	\$ -
Totals	\$ -	\$ -	\$ -	\$ -

	Current Local Budget	Billed to Date	Obligated* Local Budget	Remaining Local Budget
Personnel	\$ -	\$ -	\$ -	\$ -
Fringe	\$ -	\$ -	\$ -	\$ -
Travel	\$ -	\$ -	\$ -	\$ -
Supplies	\$ -	\$ -	\$ -	\$ -
Equipment	\$ -	\$ -	\$ -	\$ -
Contractual	\$ -	\$ -	\$ -	\$ -
Other	\$ -	\$ -	\$ -	\$ -
Subtotal	\$ -	\$ -	\$ -	\$ -
Indirect Costs	\$ -	\$ -	\$ -	\$ -
Totals	\$ -	\$ -	\$ -	\$ -

	Current 3rd Party Budget	Billed to Date	Obligated* 3rd Party Budget	Remaining 3rd Party Budget
Personnel	\$ -	\$ -	\$ -	\$ -
Fringe	\$ -	\$ -	\$ -	\$ -
Travel	\$ -	\$ -	\$ -	\$ -
Supplies	\$ -	\$ -	\$ -	\$ -
Equipment	\$ -	\$ -	\$ -	\$ -
Contractual	\$ -	\$ -	\$ -	\$ -
Other	\$ -	\$ -	\$ -	\$ -
Subtotal	\$ -	\$ -	\$ -	\$ -
Indirect Costs	\$ -	\$ -	\$ -	\$ -

*Obligated includes - funds that have been incurred by the recipient but have not been paid by the recipient, such as executed contract agreements or acquired supplies/materials/equipment.

INVOICE FOR FEDERAL EXPENDITURES

Entity Name _____
 Department _____
 Address _____
 City, State Zip _____

Contact Name _____
 Phone _____
 Fax _____

GLO Contract # _____ Federal ID# _____

Budget Category	CMP Amount Budgeted	Expenditures this Invoice	Amount Previously Invoiced	Amount Remaining
Personnel	\$0.00	\$0.00	\$0.00	\$0.00
Fringe	\$0.00	\$0.00	\$0.00	\$0.00
Travel	\$0.00	\$0.00	\$0.00	\$0.00
Supplies	\$0.00	\$0.00	\$0.00	\$0.00
Equipment	\$0.00	\$0.00	\$0.00	\$0.00
Contractual	\$0.00	\$0.00	\$0.00	\$0.00
Other	\$0.00	\$0.00	\$0.00	\$0.00
Subtotal	\$0.00	\$0.00	\$0.00	\$0.00
Indirect Costs	\$0.00	\$0.00	\$0.00	\$0.00
Totals	\$0.00	\$0.00	\$0.00	\$0.00

Attach timesheets/receipts/cancelled checks for all expenditures that you are submitting for reimbursement.*

 Project Manager Signature

 Date

*Universities may submit their standard invoice in lieu of this documentation.

For GLO Use Only:

Contract Number: _____

Invoice reviewed by Contracts Specialist _____

Req# _____ Invoice Amt\$ _____

Invoice reviewed by Project Manager _____

Req# _____ Invoice Amt\$ _____

Date _____ Service Date _____

Okay to Pay _____ Date _____

Grant Manager

13-31

MONTHLY GRANT PROJECT EQUIPMENT SHEET FOR DAILY/HOURLY RATES

Project Name:
 Employee Name:
 Month and Year:
 Equipment Used:

PLEASE PROVIDE # OF HOURS OF DAILY EQUIPMENT USE (provide copy of established rates used)

Day	Day	Day	Day	Day	Day	Day
1 _ hrs	2 _ hrs	3 _ hrs	4 _ hrs	5 _ hrs	6 _ hrs	7 _ hrs
8 _ hrs	9 _ hrs	10 _ hrs	11 _ hrs	12 _ hrs	13 _ hrs	14 _ hrs
15 _ hrs	16 _ hrs	17 _ hrs	18 _ hrs	19 _ hrs	20 _ hrs	21 _ hrs
22 _ hrs	23 _ hrs	24 _ hrs	25 _ hrs	26 _ hrs	27 _ hrs	28 _ hrs
29 _ hrs	30 _ hrs	31 _ hrs				

CALCULATION OF DAYS/HOURS:

$$\frac{0}{\text{TOTAL \# DAYS/HOURS}} \times \text{DAILY/HOURLY RATE} = \frac{0}{\text{_____}}$$

I certify that this information is correct

Printed Name of Project Manager: _____

Project Manager Signature _____

Date _____

13-32

MONTHLY GRANT PROJECT TIME SHEET

Project Name:
 Employee Name:
 Month and Year:

PLEASE PROVIDE # OF HOURS & BRIEF DESCRIPTION OF WORK PERFORMED (e.g. progress report, project meeting, planting, outreach event, field trip, etc.)

Day	Day	Day	Day	Day	Day	Day
1 hrs	2 hrs	3 hrs	4 hrs	5 hrs	6 hrs	7 hrs
8 hrs	9 hrs	10 hrs	11 hrs	12 hrs	13 hrs	14 hrs
15 hrs	16 hrs	17 hrs	18 hrs	19 hrs	20 hrs	21 hrs
22 hrs	23 hrs	24 hrs	25 hrs	26 hrs	27 hrs	28 hrs
29 hrs	30 hrs	31 hrs				

CALCULATION FOR SALARY/HOURLY:

<u>0</u>	X	=	<u>0</u>
TOTAL # HOURS		HOURLY RATE	
<u>0</u>	X	=	<u>0</u>
TOTAL SALARY/HOURLY		FRINGE BENEFIT RATE/	
WAGE FOR MONTH		HOURLY FRINGE BENEFIT RATE	
		(Not to exceed 35%)	

I certify that this information is correct

Employee Signature: _____

Date: _____

Project Manager
 Signature _____

Date _____

13-33

BUDGET AMENDMENT REQUEST

Subrecipient _____
 Department _____
 Address _____
 City, State Zip _____

Contact Name _____
 Phone _____
 Fax _____

GLO Contract # _____ Federal ID# _____

Budget Category	Current CMP Budget	Current Local Budget	Current Other Budget	Requested CMP Changes	Requested Local Changes	Requested Other Changes	Revised CMP Budget	Revised Local Budget	Revised Other Budget
Personnel	\$0.00	\$0.00	\$0.00	\$0.00	\$0.00	\$0.00	\$0.00	\$0.00	\$0.00
Fringe	\$0.00	\$0.00	\$0.00	\$0.00	\$0.00	\$0.00	\$0.00	\$0.00	\$0.00
Travel	\$0.00	\$0.00	\$0.00	\$0.00	\$0.00	\$0.00	\$0.00	\$0.00	\$0.00
Supplies	\$0.00	\$0.00	\$0.00	\$0.00	\$0.00	\$0.00	\$0.00	\$0.00	\$0.00
Equipment	\$0.00	\$0.00	\$0.00	\$0.00	\$0.00	\$0.00	\$0.00	\$0.00	\$0.00
Contractual	\$0.00	\$0.00	\$0.00	\$0.00	\$0.00	\$0.00	\$0.00	\$0.00	\$0.00
Other	\$0.00	\$0.00	\$0.00	\$0.00	\$0.00	\$0.00	\$0.00	\$0.00	\$0.00
Subtotal	\$0.00	\$0.00	\$0.00	\$0.00	\$0.00	\$0.00	\$0.00	\$0.00	\$0.00
Indirect Costs	\$0.00	\$0.00	\$0.00	\$0.00	\$0.00	\$0.00	\$0.00	\$0.00	\$0.00
Totals	\$0.00	\$0.00	\$0.00	\$0.00	\$0.00	\$0.00	\$0.00	\$0.00	\$0.00

Please justify your request below (include additional sheets, as necessary).

Signature of Authorizing Official _____

Date _____

For GLO Use Only:

Your informal budget amendment is approved. Please retain a copy of this form with your project file.

Informal Budget Amendment Approved by: _____ Date: _____
 Contract Specialist

Note: This copy of this form will become part of your permanent GLO legal file.

13-34

Audit Reporting Form

Subrecipients receiving (granted/awarded) federal funds, through the General Land Office (GLO), are subject to the requirements of the Single Audit Act of 1996, Office of Management and Budget (OMB) Circular No. A-133, (<http://www.omb.gov/grants>). Subrecipients expending (spending/reimbursed) federal funds totaling \$500,000 or more in a fiscal year are required to conduct an audit in accordance with the Single Audit Act.

Please complete this questionnaire and send by facsimile to 512-475-0680 attn: Coastal Management Program or mail to:

General Land Office
Attn: Coastal Management Program
Coastal Resources Division
P.O. Box 12873
Austin, Texas 78711-2873

Section 1: Entity Information

Name of Entity (Subrecipient) _____

Project Title and GLO Contract Number
(additional grants may be listed on a separate page)

What is your entity's fiscal year?

_____ through _____
Month / Year

through

_____ Month / Year

Section 2: Single Audit Requirement

For your most recently completed fiscal year, account for all federal funds (awards/grants) expended (spent/reimbursed) regardless of the source. (Provide your most recently completed fiscal year below)

For Fiscal Year 20__:

What was the total amount of federal funds (awards/grants) expended (spent/reimbursed)? \$ _____

- If less than \$500,000 in total federal funds (awards/grants) were expended: Your entity is *exempt* from further audit requirements for the reporting period. Complete Sections 4 and 5 (Federal Awards Information and Signature Sections).
- If \$500,000 or more in total federal funds (awards/grants) were expended: Complete all remaining sections.

Section 3: Audit Information

- Date of your Entity's last completed audit: _____ (Date)
- Period Covered by Audit: _____ through _____
Month/Year Month/Year
- Audit Findings: No Findings (it is not necessary to submit a copy of your audit report package)
 Findings (provide a copy of your audit reporting package if findings were related to funds issued through the GLO. If findings were unrelated to GLO issued funds submit the schedule of findings and questioned costs.)
- Next audit scheduled for: _____ (Month/Year)
- Period to be covered by next scheduled audit: _____ through _____
Month/Year Month/Year

Section 4: Federal Awards Information

For the fiscal year provided, account for all federal funds (awards/grants) received (granted/awarded) regardless of the source.

For Fiscal Year 20__ (fiscal year must match fiscal year provided in section 2)

What was the total amount of federal funds (awards/grants) received (granted/awarded)? \$ _____

(For the fiscal year listed, use the following table to list the federal funds (awards/grants) your entity received)

Name of federal award(s) granted	Period of Award (month/yr - month/yr)	Amount	CFDA Number

Section 5: Signature Section

Signature of Preparer _____

Date _____

Printed Name of Preparer and Title _____

Preparer's Contact Information:

Email: _____

Phone: (____) _____ - _____ ext. _____

13-35

Instruction Sheet for the Audit Reporting Form

The purpose of the Audit Reporting (AR) Form is to assist the General Land Office (GLO) in its obligations to adhere to federal guidelines for pass through entities issuing federal funds. The AR Form is equally beneficial in assisting entities receiving federal funds, through the GLO, to meet their audit reporting requirement. Federal guidelines for pass through agencies issuing federal awards and the subrecipients of those funds are set forth in the Single Audit Act of 1996, Office of Management and Budget (OMB) Circular No. A-133. The OMB's website, <http://www.omb.gov/grants>, contains information regarding the Single Audit Act and its requirements.

Review the following instructions for assistance in completing the Audit Reporting Form.

Section 1: Entity Information.

- Name of Entity – The “Name of Entity” should match the name on the grant contract.
- Project Title and GLO Contract Number – Provide the “Project Title and GLO Contract Number” for your entity’s grant. The project title must match the title of the project found in “Attachment A” of the grant contract. A separate sheet listing additional project titles and contract numbers may be attached if necessary.
- Entity’s Fiscal Year – Provide the period covered by your entity’s fiscal year. (i.e. Jan. ‘06 through Dec. ‘06)

Section 2: Single Audit Requirement.

Following the text “For Fiscal Year 20__”, insert your entity’s fiscal year end for the reporting period (the most recently complete fiscal year). For the fiscal year listed, provide the total amount of federal funds (awards/grants) expended (spent/reimbursed). Account for all federal funds expended, regardless of the source.

Choose one of the following options:

1. Mark the first box, if your entity has expended less than \$500,000 in total federal funds. Your entity is exempt from further audit requirements for the reporting period, but must complete Sections 4 and 5.
2. Mark the second box, if your entity has expended \$500,000 or more in total federal funds. Your entity is not exempt from further audit requirements and must complete all remaining sections of the form.

Section 3: Audit Information.

- Date of Last Completed Audit – Indicate the date of your entity’s last completed audit.
- Period Covered by Audit – Provide the period covered by your entity’s last completed audit. This period should correspond to the audit indicated on the previous line.
- Audit Findings – Choose one of the following options:
 1. Mark the box before “No findings” if your entity’s last completed audit disclosed no findings. If there were no findings, it is not necessary to provide a copy of your audit reporting package.
 2. Mark the box before “Findings” if your entity’s last completed audit disclosed findings. If there were findings, submit a copy of the audit reporting package, if the findings were related to GLO issued funds. If the findings were unrelated to GLO issued funds submit a copy of the schedule of findings and questioned costs.
- Next Audit Scheduled for - Provide the month and year of your entity’s next scheduled audit.
- Period Covered by Next Audit – Indicate the period to be covered by your entity’s next scheduled audit.

Section 4: Federal Awards Information.

- Following the text “For Fiscal Year 20__”, insert your entity’s fiscal year end for the current reporting period (should match the fiscal year provided in Section 2). For the fiscal year listed, provide the total amount of federal funds (awards/grants) your entity has received (granted/awarded). Account for all federal funds received, regardless of the source. It is possible for the amount of federal funds received/awarded to not agree to the amount expended/spent.
- Federal Grants Table – For the fiscal year listed, use the table to provide: 1) the grants/awards that comprise the total amount of federal funds your entity received; 2) the period of awards (i.e. May ‘06 – May ‘08); 3) amount of awards; and, 4) the Catalog of Federal Domestic Assistance (CFDA) numbers for each award. If the CFDA number is unknown, you may contact the issuing agency. If additional space is needed, attach a separate sheet listing the abovementioned federal grant information.

Section 5: Signature Section.

- Signature of Preparer – The person who prepared the AR form must sign and date the form.
- Printed Name of Preparer – Print the name and title of the person who prepared the AR Form.
- Preparer’s Contact Information – Provide an email address and phone number for the preparer.

Form Return Information – Use the return information near the top of the Audit Reporting Form.

For additional assistance contact Melissa Porter, CMP Team Leader, at 512-475-1393 or by email at melissa.porter@glo.state.tx.us.

13-36

ASSURANCES - CONSTRUCTION PROGRAMS

Public reporting burden for this collection of information is estimated to average 15 minutes per response, including time for reviewing instructions, searching existing data sources, gathering and maintaining the data needed, and completing and reviewing the collection of information. Send comments regarding the burden estimate or any other aspect of this collection of information, including suggestions for reducing this burden, to the Office of Management and Budget, Paperwork Reduction Project (0348-0042), Washington, DC 20503.

PLEASE DO NOT RETURN YOUR COMPLETED FORM TO THE OFFICE OF MANAGEMENT AND BUDGET. SEND IT TO THE ADDRESS PROVIDED BY THE SPONSORING AGENCY.

NOTE: Certain of these assurances may not be applicable to your project or program. If you have questions, please contact the Awarding Agency. Further, certain Federal assistance awarding agencies may require applicants to certify to additional assurances. If such is the case, you will be notified.

As the duly authorized representative of the applicant, I certify that the applicant:

1. Has the legal authority to apply for Federal assistance, and the institutional, managerial and financial capability (including funds sufficient to pay the non-Federal share of project costs) to ensure proper planning, management and completion of the project described in this application.
2. Will give the awarding agency, the Comptroller General of the United States and, if appropriate, the State, through any authorized representative, access to and the right to examine all records, books, papers, or documents related to the assistance; and will establish a proper accounting system in accordance with generally accepted accounting standards or agency directives.
3. Will not dispose of, modify the use of, or change the terms of the real property title, or other interest in the site and facilities without permission and instructions from the awarding agency. Will record the Federal interest in the title of real property in accordance with awarding agency directives and will include a covenant in the title of real property acquired in whole or in part with Federal assistance funds to assure non-discrimination during the useful life of the project.
4. Will comply with the requirements of the assistance awarding agency with regard to the drafting, review and approval of construction plans and specifications.
5. Will provide and maintain competent and adequate engineering supervision at the construction site to ensure that the complete work conforms with the approved plans and specifications and will furnish progress reports and such other information as may be required by the assistance awarding agency or State.
6. Will initiate and complete the work within the applicable time frame after receipt of approval of the awarding agency.
7. Will establish safeguards to prohibit employees from using their positions for a purpose that constitutes or presents the appearance of personal or organizational conflict of interest, or personal gain.
8. Will comply with the Intergovernmental Personnel Act of 1970 (42 U.S.C. §§4728-4763) relating to prescribed standards for merit systems for programs funded under one of the 19 statutes or regulations specified in Appendix A of OPM's Standards for a Merit System of Personnel Administration (5 C.F.R. 900, Subpart F).
9. Will comply with the Lead-Based Paint Poisoning Prevention Act (42 U.S.C. §§4801 et seq.) which prohibits the use of lead-based paint in construction or rehabilitation of residence structures.
10. Will comply with all Federal statutes relating to non-discrimination. These include but are not limited to: (a) Title VI of the Civil Rights Act of 1964 (P.L. 88-352) which prohibits discrimination on the basis of race, color or national origin; (b) Title IX of the Education Amendments of 1972, as amended (20 U.S.C. §§1681-1683, and 1685-1686), which prohibits discrimination on the basis of sex; (c) Section 504 of the Rehabilitation Act of 1973, as amended (29 U.S.C. §794), which prohibits discrimination on the basis of handicaps; (d) the Age Discrimination Act of 1975, as amended (42 U.S.C. §§6101-6107), which prohibits discrimination on the basis of age; (e) the Drug Abuse Office and Treatment Act of 1972 (P.L. 92-255), as amended, relating to nondiscrimination on the basis of drug abuse; (f) the Comprehensive Alcohol Abuse and Alcoholism Prevention, Treatment and Rehabilitation Act of 1970 (P.L. 91-616), as amended, relating to nondiscrimination on the basis of alcohol abuse or alcoholism; (g) §§523 and 527 of the Public Health Service Act of 1912 (42 U.S.C. §§290 dd-3 and 290 ee-3), as amended, relating to confidentiality of alcohol and drug abuse patient records; (h) Title VIII of the Civil Rights Act of 1968 (42 U.S.C. §§3601 et seq.), as amended, relating to nondiscrimination in the sale, rental or financing of housing; (i) any other nondiscrimination provisions in the specific statute(s) under which application for Federal assistance is being made; and, (j) the requirements of any other nondiscrimination statute(s) which may apply to the application.

11. Will comply, or has already complied, with the requirements of Titles II and III of the Uniform Relocation Assistance and Real Property Acquisition Policies Act of 1970 (P.L. 91-646) which provide for fair and equitable treatment of persons displaced or whose property is acquired as a result of Federal and federally-assisted programs. These requirements apply to all interests in real property acquired for project purposes regardless of Federal participation in purchases.
12. Will comply with the provisions of the Hatch Act (5 U.S.C. §§1501-1508 and 7324-7328) which limit the political activities of employees whose principal employment activities are funded in whole or in part with Federal funds.
13. Will comply, as applicable, with the provisions of the Davis-Bacon Act (40 U.S.C. §§276a to 276a-7), the Copeland Act (40 U.S.C. §276c and 18 U.S.C. §874), and the Contract Work Hours and Safety Standards Act (40 U.S.C. §§327-333) regarding labor standards for federally-assisted construction subagreements.
14. Will comply with flood insurance purchase requirements of Section 102(a) of the Flood Disaster Protection Act of 1973 (P.L. 93-234) which requires recipients in a special flood hazard area to participate in the program and to purchase flood insurance if the total cost of insurable construction and acquisition is \$10,000 or more.
15. Will comply with environmental standards which may be prescribed pursuant to the following: (a) institution of environmental quality control measures under the National Environmental Policy Act of 1969 (P.L. 91-190) and Executive Order (EO) 11514; (b) notification of violating facilities pursuant to EO 11738; (c) protection of wetlands pursuant to EO 11990; (d) evaluation of flood hazards in floodplains in accordance with EO 11988; (e) assurance of project consistency with the approved State management program developed under the Coastal Zone Management Act of 1972 (16 U.S.C. §§1451 et seq.); (f) conformity of Federal actions to State (Clean Air) Implementation Plans under Section 176(c) of the Clean Air Act of 1955, as amended (42 U.S.C. §§7401 et seq.); (g) protection of underground sources of drinking water under the Safe Drinking Water Act of 1974, as amended (P.L. 93-523); and, (h) protection of endangered species under the Endangered Species Act of 1973, as amended (P.L. 93-205).
16. Will comply with the Wild and Scenic Rivers Act of 1968 (16 U.S.C. §§1271 et seq.) related to protecting components or potential components of the national wild and scenic rivers system.
17. Will assist the awarding agency in assuring compliance with Section 106 of the National Historic Preservation Act of 1966, as amended (16 U.S.C. §470), EO 11593 (identification and protection of historic properties), and the Archaeological and Historic Preservation Act of 1974 (16 U.S.C. §§469a-1 et seq.).
18. Will cause to be performed the required financial and compliance audits in accordance with the Single Audit Act Amendments of 1996 and OMB Circular No. A-133, "Audits of States, Local Governments, and Non-Profit Organizations."
19. Will comply with all applicable requirements of all other Federal laws, executive orders, regulations, and policies governing this program.

SIGNATURE OF AUTHORIZED CERTIFYING OFFICIAL	TITLE
APPLICANT ORGANIZATION	DATE SUBMITTED

FORM CD-512
(REV 12-04)

U.S. DEPARTMENT OF COMMERCE

CERTIFICATION REGARDING LOBBYING LOWER TIER COVERED TRANSACTIONS

Applicants should review the instructions for certification included in the regulations before completing this form. Signature on this form provides for compliance with certification requirements under 15 CFR Part 28, "New Restrictions on Lobbying."

LOBBYING

As required by Section 1352, Title 31 of the U.S. Code, and implemented at 15 CFR Part 28, for persons entering into a grant, cooperative agreement or contract over \$100,000 or a loan or loan guarantee over \$150,000 as defined at 15 CFR Part 28, Sections 28.105 and 28.110, the applicant certifies that to the best of his or her knowledge and belief, that:

(1) No Federal appropriated funds have been paid or will be paid, by or on behalf of the undersigned, to any person for influencing or attempting to influence an officer or employee of any agency, a Member of Congress in connection with the awarding of any Federal contract, the making of any Federal grant, the making of any Federal loan, the entering into of any cooperative agreement, and the extension, continuation, renewal, amendment, or modification of any Federal contract, grant, loan, or cooperative agreement.

(2) If any funds other than Federal appropriated funds have been paid or will be paid to any person for influencing or attempting to influence an officer or employee of any agency, a Member of Congress, an officer or employee of Congress, or an employee of a member of Congress in connection with this Federal contract, grant, loan, or cooperative agreement, the undersigned shall complete and submit Standard Form-LLL, "Disclosure Form to Report Lobbying," in accordance with its instructions.

(3) The undersigned shall require that the language of this certification be included in the award documents for all subawards at all tiers (including subcontracts, subgrants, and contracts under grants, loans, and cooperative agreements) and that all subrecipients shall certify and disclose accordingly.

This certification is a material representation of fact upon which reliance was placed when this transaction was made or entered into. Submission of this certification is a prerequisite for making or entering into this transaction imposed by section 1352, title 31, U.S. Code. Any person who fails to file the required certification shall be subject to a civil penalty of not less than \$10,000 and not more than \$100,000 for each such failure occurring on or before October 23, 1996, and of not less than \$11,000 and not more than \$110,000 for each such failure occurring after October 23, 1996.

As the duly authorized representative of the applicant, I hereby certify that the applicant will comply with the above applicable certification.

NAME OF APPLICANT

AWARD NUMBER AND/OR PROJECT NAME

PRINTED NAME AND TITLE OF AUTHORIZED REPRESENTATIVE

SIGNATURE

DATE

13-39

DISCLOSURE OF LOBBYING ACTIVITIES

Complete this form to disclose lobbying activities pursuant to 31 U.S.C. 1352
(See reverse for public burden disclosure.)

Approved by OMB
0348-0046

1. Type of Federal Action: <input type="checkbox"/> a. contract <input type="checkbox"/> b. grant <input type="checkbox"/> c. cooperative agreement <input type="checkbox"/> d. loan <input type="checkbox"/> e. loan guarantee <input type="checkbox"/> f. loan insurance	2. Status of Federal Action: <input type="checkbox"/> a. bid/offer/application <input type="checkbox"/> b. initial award <input type="checkbox"/> c. post-award	3. Report Type: <input type="checkbox"/> a. initial filing <input type="checkbox"/> b. material change For Material Change Only: year _____ quarter _____ date of last report _____
4. Name and Address of Reporting Entity: <input type="checkbox"/> Prime <input type="checkbox"/> Subawardee Tier _____, if known: Congressional District, if known: ^{4c}	5. If Reporting Entity in No. 4 is a Subawardee, Enter Name and Address of Prime: Congressional District, if known:	
6. Federal Department/Agency:	7. Federal Program Name/Description: CFDA Number, if applicable: _____	
8. Federal Action Number, if known:	9. Award Amount, if known: \$ _____	
10. a. Name and Address of Lobbying Registrant (if individual, last name, first name, MI):	b. Individuals Performing Services (including address if different from No. 10a) (last name, first name, MI):	
11. Information requested through this form is authorized by title 31 U.S.C. section 1352. This disclosure of lobbying activities is a material representation of fact upon which reliance was placed by the tier above when this transaction was made or entered into. This disclosure is required pursuant to 31 U.S.C. 1352. This information will be available for public inspection. Any person who fails to file the required disclosure shall be subject to a civil penalty of not less than \$10,000 and not more than \$100,000 for each such failure.	Signature: _____ Print Name: _____ Title: _____ Telephone No.: _____ Date: _____	
Federal Use Only:		Authorized for Local Reproduction Standard Form LLL (Rev. 7-97)

13-40

INSTRUCTIONS FOR COMPLETION OF SF-LLL, DISCLOSURE OF LOBBYING ACTIVITIES

This disclosure form shall be completed by the reporting entity, whether subawardee or prime Federal recipient, at the initiation or receipt of a covered Federal action, or a material change to a previous filing, pursuant to title 31 U.S.C. section 1352. The filing of a form is required for each payment or agreement to make payment to any lobbying entity for influencing or attempting to influence an officer or employee of any agency, a Member of Congress, an officer or employee of Congress, or an employee of a Member of Congress in connection with a covered Federal action. Complete all items that apply for both the initial filing and material change report. Refer to the implementing guidance published by the Office of Management and Budget for additional information.

1. Identify the type of covered Federal action for which lobbying activity is and/or has been secured to influence the outcome of a covered Federal action.
2. Identify the status of the covered Federal action.
3. Identify the appropriate classification of this report. If this is a followup report caused by a material change to the information previously reported, enter the year and quarter in which the change occurred. Enter the date of the last previously submitted report by this reporting entity for this covered Federal action.
4. Enter the full name, address, city, State and zip code of the reporting entity. Include Congressional District, if known. Check the appropriate classification of the reporting entity that designates if it is, or expects to be, a prime or subaward recipient. Identify the tier of the subawardee, e.g., the first subawardee of the prime is the 1st tier. Subawards include but are not limited to subcontracts, subgrants and contract awards under grants.
5. If the organization filing the report in item 4 checks "Subawardee," then enter the full name, address, city, State and zip code of the prime Federal recipient. Include Congressional District, if known.
6. Enter the name of the Federal agency making the award or loan commitment. Include at least one organizational level below agency name, if known. For example, Department of Transportation, United States Coast Guard.
7. Enter the Federal program name or description for the covered Federal action (item 1). If known, enter the full Catalog of Federal Domestic Assistance (CFDA) number for grants, cooperative agreements, loans, and loan commitments.
8. Enter the most appropriate Federal identifying number available for the Federal action identified in item 1 (e.g., Request for Proposal (RFP) number; Invitation for Bid (IFB) number; grant announcement number; the contract, grant, or loan award number; the application/proposal control number assigned by the Federal agency). Include prefixes, e.g., "RFP-DE-90-001."
9. For a covered Federal action where there has been an award or loan commitment by the Federal agency, enter the Federal amount of the award/loan commitment for the prime entity identified in item 4 or 5.
10. (a) Enter the full name, address, city, State and zip code of the lobbying registrant under the Lobbying Disclosure Act of 1995 engaged by the reporting entity identified in item 4 to influence the covered Federal action.

(b) Enter the full names of the individual(s) performing services, and include full address if different from 10 (a). Enter Last Name, First Name, and Middle Initial (MI).
11. The certifying official shall sign and date the form, print his/her name, title, and telephone number.

According to the Paperwork Reduction Act, as amended, no persons are required to respond to a collection of information unless it displays a valid OMB Control Number. The valid OMB control number for this information collection is OMB No. 0348-0046. Public reporting burden for this collection of information is estimated to average 10 minutes per response, including time for reviewing instructions, searching existing data sources, gathering and maintaining the data needed, and completing and reviewing the collection of information. Send comments regarding the burden estimate or any other aspect of this collection of information, including suggestions for reducing this burden, to the Office of Management and Budget, Paperwork Reduction Project (0348-0046), Washington, DC 20503.

1341

**HISTORICALLY UNDERUTILIZED BUSINESSES (HUB)
EXPENSE REPORT**

(Project Name)

(Subrecipient Name)

(GLO Contract No.)

(Reporting Period)

In accordance with state law, it is the General Land Office's (GLO) policy to assist Historically Underutilized Businesses (HUBs), whether minority or women-owned, whenever possible in providing goods and services to the GLO. The GLO encourages you to adhere to this same policy when selecting subcontractors to assist your organization in fulfilling its contractual obligations with the GLO.

In that regard, please provide us with the estimated amount of project funds your organization paid to HUB vendors during the FY 20____ (the state's fiscal year is September 1 to August 31).

PROJECT AMOUNT PAID:	VENDOR NAME:	TYPE OF HUB VENDOR:
_____	_____	American Women (WO)
_____	_____	Hispanic Americans (HI)
_____	_____	Black Americans (BL)
_____	_____	Asian Pacific Americans (AS)
_____	_____	Native Americans (NA)
_____	_____	Other

I am not sure if the following vendor is a HUB:

Vendor's name _____

Amount paid: \$ _____

or

_____ No project funds were paid to a HUB vendor during the stated time period.

Please fax this page to Ms. Monica Simien, Contract Specialist, fax number: (512) 475-0680.

If you have questions, please contact Ms. Simien at (512) 463-5187, or via electronic mail at: monica.simien@glo.state.tx.us.

13-42

GENERAL AFFIRMATIONS

Provider agrees without exception to the following affirmations:

1. The Provider has not given, offered to give, nor intends to give at anytime hereafter any economic opportunity, future employment, gift, loan, gratuity, special discount, trip, favor, or service to a public servant in connection with this Contract.
2. Pursuant to Title 10, Section 2155.004 of the Texas Government Code, the Provider has not received compensation from the GLO for preparing any part of this Contract.
3. Under Section 231.006, Family Code, the vendor or applicant certifies that the individual or business entity named in this contract, bid, or application is not ineligible to receive the specified grant, loan, or payment and acknowledges that this contract may be terminated and payment may be withheld if this certification is inaccurate. Any Provider subject to this section must include names and Social Security numbers of each person with at least twenty-five percent (25%) ownership in the business entity named in this Contract. This information must be provided prior to execution of any offer.
4. Provider certifies that the individual or business entity named in this Contract: i) has not been subjected to suspension, debarment, or similar ineligibility to receive the specified contract as determined by any federal, state, or local governmental entity; ii) is in compliance with the State of Texas statutes and rules relating to procurement; and iii) is not listed on the federal government's terrorism watch list as described in executive order 13224. Entities ineligible for federal procurement are listed at <http://www.epls.gov>. Provider acknowledges that this contract may be terminated and payment withheld if this certification is inaccurate.
5. Provider agrees that any payments due under this Contract will be applied towards any debt, including, but not limited to, delinquent taxes and child support that is owed to the State of Texas.
6. Provider certifies that they are in compliance with Texas Government Code, Title 6, Subtitle B, Section 669.003, relating to contracting with the executive head of a state agency. If this section applies, Provider will complete the following information in order for the bid to be evaluated:

Name of Former Executive: _____
 Name of State Agency: _____
 Date of Separation from State Agency: _____
 Position with Provider: _____
 Date of Employment with Provider: _____

7. Provider agrees to comply with Texas Government Code, Title 10, Subtitle D, Section 2155.4441, relating to the purchase of products produced in the State of Texas under service contracts.

13-413

8. Provider understands that acceptance of funds under this Contract acts as acceptance of the authority of the State Auditor's Office, or any successor agency, to conduct an audit or investigation in connection with those funds. Provider further agrees to cooperate fully with the State Auditor's Office, or its successor, in conducting the audit or investigation, including providing all records requested. Provider will ensure that this clause is included in any subcontract it awards.
9. Provider certifies that if it employs any former employee of the GLO, such employee will perform no work in connection with this Contract during the twelve (12) month period immediately following the employee's last date of employment at the GLO.
10. The Provider shall not discriminate against any employee or applicant for employment because of race, disability, color, religion, sex, age, or national origin. The Provider shall take affirmative action to ensure that applicants are employed and that employees are treated without regard to their race, color, sex, religion, age, disability, or national origin. Such action shall include, but is not be limited to, the following: employment, upgrading, demotion, or transfer; recruitment or recruitment advertising; layoff or termination; rates of pay or other forms of compensation; and selection for training, including apprenticeship. The Provider agrees to post notices, which set forth the provisions of this non-discrimination article, in conspicuous places available to employees or applicants for employment. The Provider shall include the above provisions in all subcontracts pertaining to the work.
11. Provider understands that the GLO does not tolerate any type of fraud. The agency's policy is to promote consistent, legal, and ethical organizational behavior by assigning responsibilities and providing guidelines to enforce controls. Any violations of law, agency policies, or standards of ethical conduct will be investigated, and appropriate actions will be taken. Providers are expected to report any possible fraudulent or dishonest acts, waste, or abuse affecting any transaction with the GLO to the GLO's Internal Audit Director at 512.463.5338 or tracey.hall@glo.state.tx.us

NOTE: Information, documentation, and other material in connection with this Contract may be subject to public disclosure pursuant to the "Public Information Act," Chapter 552 of the Texas Government Code.

REMAINDER OF PAGE INTENTIONALLY LEFT BLANK

**CITY OF SOUTH PADRE ISLAND
CITY COUNCIL MEETING
AGENDA REQUEST FORM**

MEETING DATE: October 6, 2010

NAME/DEPT.: Victor Baldovinos, Environmental Health Services Director

ITEM

Discussion and action to approve a budget amendment in the amount of \$31,400 for an amendment to the grant that was originally approved January 20, 2010 with the Lower Rio Grande Valley Development Council for a Regional Solid Waste Grants Program in which the City of South Padre Island wishes to purchase two recycling trailers. (Jones/Baldovinos)

ITEM BACKGROUND

On January 20, 2010, City Council approved an inter-local agreement contract with the Lower Rio Grande Valley Development Council for a Regional Solid Waste Grants Program. On August 4, 2010 City Council approved the acceptance the funds on a reimbursement basis for the LRGVDC for two recycling trailers. The funds are not going to be expended in the 2009-2010 budget, therefore requiring us to seek City Council permission to spend the funds in the 2010-2011 budget.

The Solid Waste Advisory Committee, an advisory board to the Lower Rio Grande Valley Development Council, approved the City's request for an amendment to our grant. We proposed to purchase two recycling trailers as opposed to building a recycling facility. This allows us to take the trailers out to Coca-Cola Beach during Spring Break, BikeFest and other heavily attended events to increase participation in our recycling program.

RECOMMENDATIONS/COMMENTS

Staff recommends approval.

BUDGET/FINANCIAL SUMMARY

Line item 01 532-1004 will be increased in the amount of \$31,400.00. \$30,000 of this amount will be received from the LRGVDC as the reimbursement grant.

COMPREHENSIVE PLAN GOAL

- 3-1 Premise – 1. Preserving and enhancing the Quality of Life
 - 4. Preserving our natural assets
- 5.M Conserve environmentally sensitive land
- 6.I Continue to provide adequate services
- 7.E Support an environment that is friendly to residents and businesses.

COUNCIL ACTION

Motion: _____

Second: _____

Vote: Ayes: _____ Nays: _____

Abstentions: _____

For TCEQ Use

Pnumber: _____ *PRange:* _____ *PCode:* _____

Capsule Description:

**FY2010/2011 REGIONAL SOLID WASTE GRANTS PROGRAM
Implementation Project Summary Form**

New Revised

COG Name: Lower Rio Grande Valley Development Council

Date: October 26, 2009

Revision Date: September 28, 2010

Fiscal Year: FY-2010

Grant Recipient: Town of South Padre Island	Total Grant Funding: \$30,000.00
Counties to be Served: Cameron	Matching/In-Kind Services: \$5,455
Contract Dates: October 1, 2009 to November 31, 2010	Regional Plan Goal #(s): 1
Project Category: (choose one) <input type="checkbox"/> Local Enforcement <input type="checkbox"/> Litter & Illegal Dumping / Community Cleanups <input checked="" type="checkbox"/> Source Reduction & Recycling <input type="checkbox"/> Local Solid Waste Management Plans <input type="checkbox"/> Citizens' Collection Station / "Small Registered Transfer Station" <input type="checkbox"/> HHW Management <input type="checkbox"/> Technical Studies <input type="checkbox"/> Education & Training <input type="checkbox"/> Other (specify) _____	Check ONE best describing the project: <input checked="" type="checkbox"/> New Project <input type="checkbox"/> Enhancement/expansion of existing project <input type="checkbox"/> Continuation of an existing project Check ANY which pertain to the project: <input type="checkbox"/> Educational/training component <input type="checkbox"/> Public/private partnership <input type="checkbox"/> Cooperative effort between more than one local government

Were there any unresolved private industry concerns expressed about the project?

No Yes (documents attached)

BUDGET CATEGORY	FUNDING AMOUNT
Personnel / Salaries <i>List personnel, # of hours, salary charged to grant</i>	\$
Fringe Benefits	\$
Travel <i>List & itemize travel expenditures</i>	\$
Supplies <i>List & itemize detailed travel expenditures</i>	\$
Equipment <i>List & itemize equipment expenditures (must have a unit cost of \$5,000 or more)</i> (2) Recycling Trailers	\$ 30,000.00
Construction <i>List & itemize construction expenditures</i>	\$
Contractual <i>List & itemize contractual expenditures (other than construction)</i>	\$
Other <i>List & itemize other expenditures</i>	\$
Indirect Charges	\$

TOTAL FUNDING \$ 30,000.00

Project Description:

(Provide a detailed description on this project, including the following information if applicable. How does this project support the COG's regional solid waste management plan? Why is this project necessary and a good use of funds? Who will directly benefit from the project? What exactly will the funds be used for? When and where will the events be held? Where will equipment be stored and how often will it be used? What will happen with funds generated from this project?)

The City will purchase two trailers with bins at \$15,700 each to be placed at different sites to collect recycle material. The trailers will serve as a way for visitors to help maintain the cleanliness of the Island and reduce waste disposal into the landfill. The project will directly benefit the residents of South Padre Island as it will help maintaining a clean and safe community along with bringing down landfill costs if the project is successful. Project will be managed by the Town of South Padre Island Health Department and all funds generated will be placed back into the program. Trailers will be placed at South Padre Recycling Center 108 West Retama, South Padre Island TX 78597 and will be moved occasionally.

CITY OF



**ENVIRONMENTAL HEALTH DEPARTMENT
4601 PADRE BOULEVARD
SOUTH PADRE ISLAND, TEXAS 78597
PHONE: (956)761-5454 EXT: 3226 – FAX (956) 761-3898**



July 27, 2010

Marcie Oviedo
LRGVDC
311 N. 15th Street
McAllen, TX 78501

Subject: Solid Waste Grant Application

Dear Ms Marcie Oviedo:

We would like to thank the LRGVDC Solid Waste Advisory Committee for awarding the City of South Padre Island a \$30,000 grant for construction and equipment.

Our bond for building a Fire Station was unsuccessful. Unfortunately, the recycling center was going to be part of the Fire Station thus, putting us a predicament. At this time, we would like to request that the construction part of this grant be moved over to equipment, to allow us the purchase of two mobile aluminum recycling trailers. These mobile recycling trailers would be purchased from Pro-Tainer for a total sum of \$31,400 and meet the expiration date of this grant. These mobile trailers would not only allow us to increase the amount of recycling that would be picked up from our citizens and tourist, but also allow us to remove these trailers from the Island in case of an emergency. We would ask for your consideration and approval regarding this request to decrease trash that leaves the Island and increase the recycling effort.

Thank you for your time,

Victor Baldovinos

14-61